



# NONRESIDENT TRAINING COURSE



April 1995

---

# Quartermaster 1 & C

NAVEDTRA 14220

## NOTICE

Pages 4-30, 4-31, 4-32, and 4-33 must be printed on a **COLOR** printer.

**Although the words “he,” “him,” and “his” are used sparingly in this course to enhance communication, they are not intended to be gender driven or to affront or discriminate against anyone.**

COMMANDING OFFICER  
NETPDTC  
6490 SAUFLEY FIELD RD  
PENSACOLA, FL 32509-5237

ERRATA #3

18 Jul 2000

Specific Instructions and Errata for  
Nonresident Training Course

QUARTERMASTER 1 & C

1. This errata supersedes all previous erratas. No attempt has been made to issue corrections for errors in typing, punctuation, etc ., that do not affect your ability to answer the question or questions.
2. To receive credit for deleted questions, show this errata to your local course administrator (ESO/scorer). The local course administrator is directed to correct the course and the answer key by indicating the questions deleted.
3. Assignment Booklet

Delete the following questions, and leave the corresponding spaces blank on the answer sheets:

<u>Questions</u>	<u>Questions</u>	<u>Questions</u>
1-30	3-29	4-33
1-38	3-33	4-34
2-9	3-34	4-35
2-30	3-35	4-38
2-37	3-36	4-42
3-5	4-7	4-52
3-8	4-9	5-28
3-13	4-27	5-29
3-26	4-29	6-17
3-27	4-32	6-18



## PREFACE

By enrolling in this self-study course, you have demonstrated a desire to improve yourself and the Navy. Remember, however, this self-study course is only one part of the total Navy training program. Practical experience, schools, selected reading, and your desire to succeed are also necessary to successfully round out a fully meaningful training program.

**COURSE OVERVIEW:** Upon completion of this course, you will have a basic knowledge of determining magnetic compass error and preparing deviation tables, voyage planning, assisting the navigator, ship operation, and weather.

**THE COURSE:** This self-study course is organized into subject matter areas, each containing learning objectives to help you determine what you should learn along with text and illustrations to help you understand the information. The subject matter reflects day-to-day requirements and experiences of personnel in the rating or skill area. It also reflects guidance provided by Enlisted Community Managers (ECMs) and other senior personnel, technical references, instructions, etc., and either the occupational or naval standards, which are listed in the *Manual of Navy Enlisted Manpower Personnel Classifications and Occupational Standards*, NAVPERS 18068.

**THE QUESTIONS:** The questions that appear in this course are designed to help you understand the material in the text.

**VALUE:** In completing this course, you will improve your military and professional knowledge. Importantly, it can also help you study for the Navy-wide advancement in rate examination. If you are studying and discover a reference in the text to another publication for further information, look it up.

*1995 Edition Prepared by*  
*QMC(SW) Jeffrey W. Yauger*  
*QMC(SW) Steven C. Zdanowicz*  
*Reviewed by*  
*QMC(SW) Pearce J. G. Durrance*  
*QMC(SW) Marvin L. Moon*  
*SMC(SW) Billy W. Hosey*

Published by  
NAVAL EDUCATION AND TRAINING  
PROFESSIONAL DEVELOPMENT  
AND TECHNOLOGY CENTER

**NAVSUP Logistics Tracking Number**  
**0504-LP-026-8590**

## **Sailor's Creed**

“I am a United States Sailor.

I will support and defend the Constitution of the United States of America and I will obey the orders of those appointed over me.

I represent the fighting spirit of the Navy and those who have gone before me to defend freedom and democracy around the world.

I proudly serve my country's Navy combat team with honor, courage and commitment.

I am committed to excellence and the fair treatment of all.”

# QUARTERMASTER-Table of Contents

---

## *Chapters*

INTRODUCTION TO NAVIGATION .....	1-1
COMPASSES .....	2-1
NAVIGATIONAL PUBLICATIONS .....	3-1
THE NAUTICAL ROAD .....	4-1
BASICS OF TIME .....	5-1
INTRODUCTION TO CELESTIAL NAVIGATION .....	6-1
TIDES AND CURRENTS .....	7-1
DEAD RECKONING, PILOTING, AND ELECTRONIC NAVIGATION .....	8-1
CELESTIAL OBSERVATIONS AND SIGHT REDUCTION METHODS .....	9-1
WEATHER OBSERVATION .....	10-1
THE SHIP'S BRIDGE .....	11-1
VOYAGE PLANNING .....	12-1

## *Appendices*

GLOSSARY .....	AI-1
REFERENCES .....	AII-1
INDEX .....	INDEX-1

# QUARTERMASTER -Table of Contents, Continued

---

## CHAPTER 1— INTRODUCTION TO NAVIGATION

•	Origins and Primary Areas of Navigation . . . . .	1-3
•	Problems Associated with Navigation . . . . .	1-6
•	Earth and the Terrestrial Coordinate System . . . . .	1-8
•	Reference Lines on Earth . . . . .	1-9
•	Nautical Chart Interpretation . . . . .	1-13
•	Chart Scale . . . . .	1-16
•	Chart Accuracy . . . . .	1-17
•	Latitude and Longitude . . . . .	1-18
•	How to Measure Distance . . . . .	1-19
•	How to Determine or Plot Direction on a Chart . . . . .	1-20
•	How to Plot a Position . . . . .	1-21
•	How to Extract Latitude and Longitude from a Known Position . . . . .	1-22
•	Defense Mapping Agency . . . . .	1-23
•	DMA Stock Numbering System . . . . .	1-25
•	The Nautical Chart Numbering System . . . . .	1-26
•	Chart Correction System . . . . .	1-28
•	Chart Card Maintenance . . . . .	1-33
•	Chart Correction Techniques . . . . .	1-35
•	Chart Ordering System . . . . .	1-37
•	Ordering, Labeling, and Stowing Charts . . . . .	1-38

## CHAPTER 2— COMPASSES

•	The Magnetic Compass . . . . .	2-2
•	Earth's Magnetic Field and Magnetism . . . . .	2-3
•	Compass Components, Types, and Operation . . . . .	2-7
•	Magnetic Compass Error . . . . .	2-9
•	The Shipboard Degaussing System . . . . .	2-12
•	Magnetic Compass Adjustment . . . . .	2-13
•	The Gyrocompass . . . . .	2-19
•	Tools Used to Determine and Plot Direction . . . . .	2-20
•	Gyrocompass Error . . . . .	2-23
•	Magnetic Compass Record Book . . . . .	2-18
•	How to Determine Gyro Error . . . . .	2-32



# QUARTERMASTER -Table of Contents, Continued

---

## CHAPTER 3— NAVIGATIONAL PUBLICATIONS

• Navigational Publication Quick Reference Guide .....	3-2
• Coast Pilots .....	3-5
• Fleet Guides .....	3-5
• Sailing Directions .....	3-6
• List of Lights .....	3-8
• Tide Tables and Tidal Current Tables .....	3-8
• Pilot Charts .....	3-8
• World Port Index .....	3-10
• Distances Between Ports .....	3-10
• Almanacs .....	3-11
• Sight Reduction Tables .....	3-11
• Publication Correction and Ordering .....	3-12

## CHAPTER 4— THE NAUTICAL ROAD

• Navigational Lights .....	4-3
• How to Use the Light List .....	4-5
• Characteristics of Lighted Aids to Navigation .....	4-6
• Visibility of Lights .....	4-8
• Types of Lights and Structures .....	4-14
• Sector Lights .....	4-21
• Buoys .....	4-24
• Buoyage Systems .....	4-28
• The United States System of Aids to Navigation .....	4-30
• Rules of the Road .....	4-39
• Maneuvering and Warning Signals .....	4-44

## CHAPTER 5— BASICS OF TIME

• Apparent Time and Mean Solar Time .....	5-3
• Definition of Terms .....	5-5
• Standard Time Zones .....	5-6
• The Relationship Between Time and Longitude .....	5-7
• How to Convert Arc to Time Using <i>The Nautical Almanac</i> .....	5-10
• How to Convert Time .....	5-11
• Time and Date for Ships at Sea .....	5-13
• Timepieces .....	5-14
• Chronometer Error .....	5-15

# QUARTERMASTER -Table of Contents, Continued

---

## CHAPTER 5— BASICS OF TIME, continued

- Documenting Chronometer Error ..... 5-17
- How to Determine Daily Rates ..... 5-18
- Timing Celestial Observations ..... 5-19

## CHAPTER 6— INTRODUCTION TO CELESTIAL NAVIGATION

- Earth and the Celestial Sphere ..... 6-2
- Understanding the Celestial Coordinate System ..... 6-3
- Using *The Nautical Almanac* ..... 6-5
- How to Determine the Time of Sunrise, Sunset, and Twilight ..... 6-6
- How to Determine the Time of Moonrise and Moonset ..... 6-8
- How to Determine Selected Stars Using Pub 249 ..... 6-9
- How to Determine Selected Stars Using *The Rude Starfinder* ..... 6-12

## CHAPTER 7— TIDES AND CURRENTS

- Effect of the Sun and Moon on Tides ..... 7-4
- Types of Tides and Reference Planes ..... 7-5
- Tide Tables ..... 7-6
- How to Determine the Height of Tide ..... 7-7
- How to Graph Tide Data ..... 7-12
- Tidal Currents ..... 7-16
- Tidal Current Tables ..... 7-18
- Current Calculations ..... 7-19
- How to Graph Tidal Currents ..... 7-23

## CHAPTER 8— DEAD RECKONING, PILOTING, AND ELECTRONIC NAVIGATION

- The DR Plot ..... 8-3
- Terms Associated with the DR Plot ..... 8-4
- Time, Speed, and Distance ..... 8-5
- Using the Nautical Slide Rule ..... 8-7
- Practice Time, Speed, and Distance Problems ..... 8-8
- Example DR Plot ..... 8-10
- Labeling the DR Plot ..... 8-11
- Plan of Intended Movement (PIM) ..... 8-12
- Plotting Instruments ..... 8-13
- Plotting Techniques ..... 8-15

# QUARTERMASTER -Table of Contents, Continued

---

## CHAPTER 8— DEAD RECKONING, PILOTING, AND ELECTRONIC NAVIGATION, continued

• Labeling the Course Line . . . . .	8-17
• Piloting . . . . .	8-18
• Lines of Position and Fixes . . . . .	8-20
• Determining the Ship's Position Using True Bearings . . . . .	8-21
• Determining the Ship's Position Using Relative Bearings . . . . .	8-22
• The Marine Sextant . . . . .	8-24
• Determining the Ship's Position Using Sextant Angles . . . . .	8-33
• Determining the Ship's Position by Running Fix . . . . .	8-39
• Using the Fathometer . . . . .	8-41
• Loran Time Difference Lines . . . . .	8-43
• Satellite Navigation Systems . . . . .	8-44
• Navigational Radar . . . . .	8-49
• Other Electronic Navigation Equipment . . . . .	8-53

## CHAPTER 9— CELESTIAL OBSERVATIONS AND SIGHT REDUCTION METHODS

• Methods For Finding Gyrocompass Error . . . . .	9-2
• Azimuth of the Sun . . . . .	9-3
• Azimuth by Polaris . . . . .	9-11
• Amplitude of the Sun . . . . .	9-12
• The Celestial LOP . . . . .	9-17
• Altitude Corrections . . . . .	9-19
• How to Reduce a Sunline Using Pub 229 . . . . .	9-24
• Plotting One or More LOPs . . . . .	9-28
• Reducing Stars, Planets, and the Moon Using Pub 229 . . . . .	9-31
• Reducing Sights Using Pub 249 . . . . .	9-32
• Latitude by Local Apparent Noon (LAN) . . . . .	9-36

## CHAPTER 10— WEATHER OBSERVATION

• The Atmosphere . . . . .	10-3
• Circulation of the Wind Upon Earth . . . . .	10-4
• Cloud Formations . . . . .	10-6
• Cloud Characteristics . . . . .	10-8
• Atmospheric Pressure . . . . .	10-11
• Pressure Areas . . . . .	10-13
• Frontal Systems . . . . .	10-15

# QUARTERMASTER -Table of Contents, Continued

---

## CHAPTER 10— WEATHER OBSERVATION, continued

- Wind ..... 10-19
- Temperature, Dew Point, and Relative Humidity ..... 10-26
- Weather Observation and Reporting ..... 10-32

## CHAPTER 11— THE SHIP’S BRIDGE

- Bridge Equipment ..... 11-3
- Ship’s Characteristics ..... 11-7
- Steering the Ship ..... 11-11
- Navigational Lights ..... 11-15
- External Communications ..... 11-19
- Bridge Watch Personnel ..... 11-21
- Relieving the QMOW ..... 11-25
- Commanding Officer’s Night Order Book ..... 11-26
- The Ship’s Deck Log ..... 11-27
- General Duties of the QMOW ..... 11-34

## CHAPTER 12— VOYAGE PLANNING

- Planning and Constructing Great Circle Tracks ..... 12-2
- Planning and Constructing Coastal Tracks ..... 12-6
- Planning and Constructing Restricted Water Tracks ..... 12-7
- Constructing Turn Bearings ..... 12-8
- Constructing Danger Bearings ..... 12-10
- Precision Anchoring ..... 12-13
- Navigation Brief ..... 12-21
- Departing Port ..... 12-22
- Entering Port ..... 12-25

## APPENDICES

**GLOSSARY** ..... AI-1

**REFERENCES** ..... AII-1

**INDEX** ..... INDEX-1

# INSTRUCTIONS FOR TAKING THE COURSE

## ASSIGNMENTS

The text pages that you are to study are listed at the beginning of each assignment. Study these pages carefully before attempting to answer the questions. Pay close attention to tables and illustrations and read the learning objectives. The learning objectives state what you should be able to do after studying the material. Answering the questions correctly helps you accomplish the objectives.

## SELECTING YOUR ANSWERS

Read each question carefully, then select the BEST answer. You may refer freely to the text. The answers must be the result of your own work and decisions. You are prohibited from referring to or copying the answers of others and from giving answers to anyone else taking the course.

## SUBMITTING YOUR ASSIGNMENTS

To have your assignments graded, you must be enrolled in the course with the Nonresident Training Course Administration Branch at the Naval Education and Training Professional Development and Technology Center (NETPDTC). Following enrollment, there are two ways of having your assignments graded: (1) use the Internet to submit your assignments as you complete them, or (2) send all the assignments at one time by mail to NETPDTC.

**Grading on the Internet:** Advantages to Internet grading are:

- you may submit your answers as soon as you complete an assignment, and
- you get your results faster; usually by the next working day (approximately 24 hours).

In addition to receiving grade results for each assignment, you will receive course completion confirmation once you have completed all the

assignments. To submit your assignment answers via the Internet, go to:

**<http://courses.cnet.navy.mil>**

**Grading by Mail:** When you submit answer sheets by mail, send all of your assignments at one time. Do NOT submit individual answer sheets for grading. Mail all of your assignments in an envelope, which you either provide yourself or obtain from your nearest Educational Services Officer (ESO). Submit answer sheets to:

COMMANDING OFFICER  
NETPDTC N331  
6490 SAUFLEY FIELD ROAD  
PENSACOLA FL 32559-5000

**Answer Sheets:** All courses include one “scannable” answer sheet for each assignment. These answer sheets are preprinted with your SSN, name, assignment number, and course number. Explanations for completing the answer sheets are on the answer sheet.

**Do not use answer sheet reproductions:** Use only the original answer sheets that we provide—reproductions will not work with our scanning equipment and cannot be processed.

Follow the instructions for marking your answers on the answer sheet. Be sure that blocks 1, 2, and 3 are filled in correctly. This information is necessary for your course to be properly processed and for you to receive credit for your work.

## COMPLETION TIME

Courses must be completed within 12 months from the date of enrollment. This includes time required to resubmit failed assignments.

## **PASS/FAIL ASSIGNMENT PROCEDURES**

If your overall course score is 3.2 or higher, you will pass the course and will not be required to resubmit assignments. Once your assignments have been graded you will receive course completion confirmation.

If you receive less than a 3.2 on any assignment and your overall course score is below 3.2, you will be given the opportunity to resubmit failed assignments. **You may resubmit failed assignments only once.** Internet students will receive notification when they have failed an assignment--they may then resubmit failed assignments on the web site. Internet students may view and print results for failed assignments from the web site. Students who submit by mail will receive a failing result letter and a new answer sheet for resubmission of each failed assignment.

## **COMPLETION CONFIRMATION**

After successfully completing this course, you will receive a letter of completion.

## **ERRATA**

Errata are used to correct minor errors or delete obsolete information in a course. Errata may also be used to provide instructions to the student. If a course has an errata, it will be included as the first page(s) after the front cover. Errata for all courses can be accessed and viewed/downloaded at:

<http://www.advancement.cnet.navy.mil>

## **STUDENT FEEDBACK QUESTIONS**

We value your suggestions, questions, and criticisms on our courses. If you would like to communicate with us regarding this course, we encourage you, if possible, to use e-mail. If you write or fax, please use a copy of the Student Comment form that follows this page.

## **For subject matter questions:**

E-mail: n314.products@cnet.navy.mil  
Phone: Comm: (850) 452-1001, Ext. 1826  
DSN: 922-1001, Ext. 1826  
FAX: (850) 452-1370  
(Do not fax answer sheets.)  
Address: COMMANDING OFFICER  
NETPDTC N314  
6490 SAUFLEY FIELD ROAD  
PENSACOLA FL 32509-5237

## **For enrollment, shipping, grading, or completion letter questions**

E-mail: fleetservices@cnet.navy.mil  
Phone: Toll Free: 877-264-8583  
Comm: (850) 452-1511/1181/1859  
DSN: 922-1511/1181/1859  
FAX: (850) 452-1370  
(Do not fax answer sheets.)  
Address: COMMANDING OFFICER  
NETPDTC N331  
6490 SAUFLEY FIELD ROAD  
PENSACOLA FL 32559-5000

## **NAVAL RESERVE RETIREMENT CREDIT**

If you are a member of the Naval Reserve, you may earn retirement points for successfully completing this course, if authorized under current directives governing retirement of Naval Reserve personnel. For Naval Reserve retirement, this course is evaluated at 9 points. (Refer to *Administrative Procedures for Naval Reservists on Inactive Duty*, BUPERSINST 1001.39, for more information about retirement points.)

## Student Comments

**Course Title:** Quartermaster I & C

**NAVEDTRA:** 14220 **Date:** \_\_\_\_\_

**We need some information about you:**

Rate/Rank and Name: \_\_\_\_\_ SSN: \_\_\_\_\_ Command/Unit \_\_\_\_\_

Street Address: \_\_\_\_\_ City: \_\_\_\_\_ State/FPO: \_\_\_\_\_ Zip \_\_\_\_\_

**Your comments, suggestions, etc.:**

<p><b>Privacy Act Statement:</b> Under authority of Title 5, USC 301, information regarding your military status is requested in processing your comments and in preparing a reply. This information will not be divulged without written authorization to anyone other than those within DOD for official use in determining performance.</p>
--

NETPDTC 1550/41 (Rev 4-00)





# CHAPTER 1

## Introduction to Navigation

---

### Introduction

In this chapter, you will be introduced to the world of navigation. As a Quartermaster, you will be engaged in many aspects of navigation. As you will learn, navigation is known as both an *art* and a *science*. Don't be put off by the science end though, a basic knowledge of mathematics will suffice your needs. There is no feeling that compares to knowing that you are part of a team that **safely** navigates a ship and her crew across vast expanses of ocean.

You will be a highly visible member of the ship's crew, after all, your work station is on the bridge. The bridge is where the captain spends most of his or her time under way. The bridge is where the orders are given for the ship to carry out her mission. QMs traditionally maintain the highest standards of **grooming, pride, and professionalism**. You will become the trusted assistant of the navigator, bridge watch officers, and the captain.

---

### Objectives

The material in this chapter will enable the student to:

- Describe a dead reckoned track.
- Describe the Terrestrial Coordinate System.
- Measure distance on a Mercator projection chart.
- Interpret chart symbology.
- Plot and extract positions on a chart.
- Plot direction on a chart.
- Determine chart accuracy.
- Find charts using DMA Hydrographic catalog.
- Describe the Chart Correction System and correct charts from *Notice to Mariners*.
- Order, label, and stow charts.

## Topics

---

<b>Topic</b>	<b>Page</b>
Origins and Primary Areas of Navigation	1-3
Problems Associated with Navigation	1-6
Earth and the Terrestrial Coordinate System	1-8
Reference Lines on Earth	1-9
Nautical Chart Interpretation	1-13
Chart Scale	1-16
Chart Accuracy	1-17
Latitude and Longitude	1-18
How to Measure Distance	1-19
How to Determine or Plot Direction on a Chart	1-20
How to Plot a Position	1-21
How to Extract Latitude and Longitude from a Known Position	1-22
Defense Mapping Agency	1-23
DMA Stock Numbering System	1-25
The Nautical Chart Numbering System	1-26
Chart Correction System	1-28
Chart Card Maintenance	1-33
Chart Correction Techniques	1-35
Chart Ordering System	1-37
Ordering, Labelling, and Stowing Charts	1-38

# Origins and Primary Areas of Navigation

---

## Background

From the beginning of recorded time, man has traveled on the water. He left port without the ability to steer a course. He was at the mercy of the sea, with his direction being determined by the wind and currents. Eventually, he faced the problem of how to get to where he wanted to go. As a result of this problem-solving process, navigation was born.

The early days of navigation were dubious at best. During this period in time, navigation was considered an art. This soon changed with the addition of science.

Modern day navigation has aspects of both, it is considered an art and a science. On one hand, navigation is a precise science comprised of complicated mathematics, precision instruments, and state of the art machinery. On the other hand, it is the skill in the use of these tools and the interpretation of information that is an art. Many operations conducted in the area of navigation require the use of precise instruments and mathematical tables and sound judgment based on experience.

The seasoned navigator uses all available information and a certain measure of judgment to say “Our position is here on a chart.”

---

## Primary Areas of Navigation

Navigation is divided into four primary areas: piloting, dead reckoning, celestial navigation, and radionavigation. These areas are listed in the sequence in which they probably evolved as knowledge and abilities progressed. We will now briefly look at each area.

---

## Piloting

Piloting may be defined as the movement of a vessel with continuous reference to landmarks, aids to navigation, depth sounding, and radionavigation.

**Example:** Our early navigator probably departed port and set his or her course towards a distant landmark. This may have been any number of things, an offshore island or a lone jagged rock outcropping. The navigator steered on this landmark and tracked his progress by landmarks passing down the port and starboard sides of his ship.

Piloting as a technique has not changed. The difference between our early navigator and the present navigator is the use of technology.

## Origins and Primary Areas of Navigation, Continued

**Dead Reckoning** Dead reckoning (DR) can be defined as projecting an intended course and speed from a known point. As our early navigators ventured further from land, they needed a method to estimate position. With no visible landmarks to use as a reference, early navigators estimated course and speed on the chart. *Dead reckoning does not consider the effects of wind or current.*

Figure 1-1 illustrates a sample DR plot. From the 0800 fix the ship's course and speed is plotted. A DR plot is maintained on board naval vessels under way at all times. It is the best estimate of where the ship should be at any given time. The DR plot also gives the navigator a visual sign of whether the ship is steering towards danger or not. The DR plot will be covered in greater detail in chapter 8.

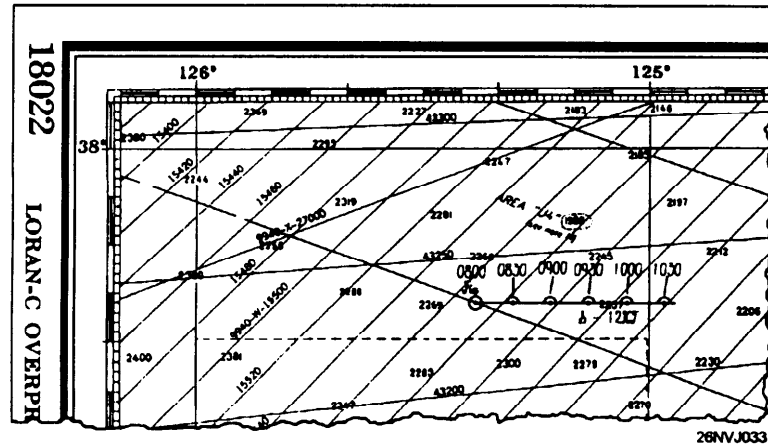

Figure 1-1. Example of a DR track.

### Celestial Navigation

Celestial navigation may be defined as the practice of observing celestial bodies (the Sun, Moon, stars, and planets) to determine the ship's position.

The early navigators recognized the need to overcome the shortcomings of dead reckoning. They soon developed techniques to observe the heavenly bodies to determine their position. Although the instruments used first were crude, they have steadily improved. An experienced QM may now obtain a celestial fix within **one-tenth of a mile** of the ship's position.

## Origins and Primary Areas of Navigation, Continued

### Celestial Navigation

How is this accomplished? Measurements are taken of the height above the horizon of a celestial body. The measurement or sight, as it is commonly referred to, is then reduced by a mathematical procedure. The results are then plotted on the chart to determine position (fig. 1-2). Celestial navigation will be covered in greater detail in chapters 6 and 9.

### Radionavigation

Radionavigation may be defined as the determination of position by the use of radio waves. There are several types of systems in use today. From the now seldom used Radio Direction Finder (RDF) to the latest satellite navigation system, what they **all** have in common is that they use radio waves. This area of navigation is now sometimes referred to as *electronic navigation*. This subject matter will be covered in greater detail in chapter 8.

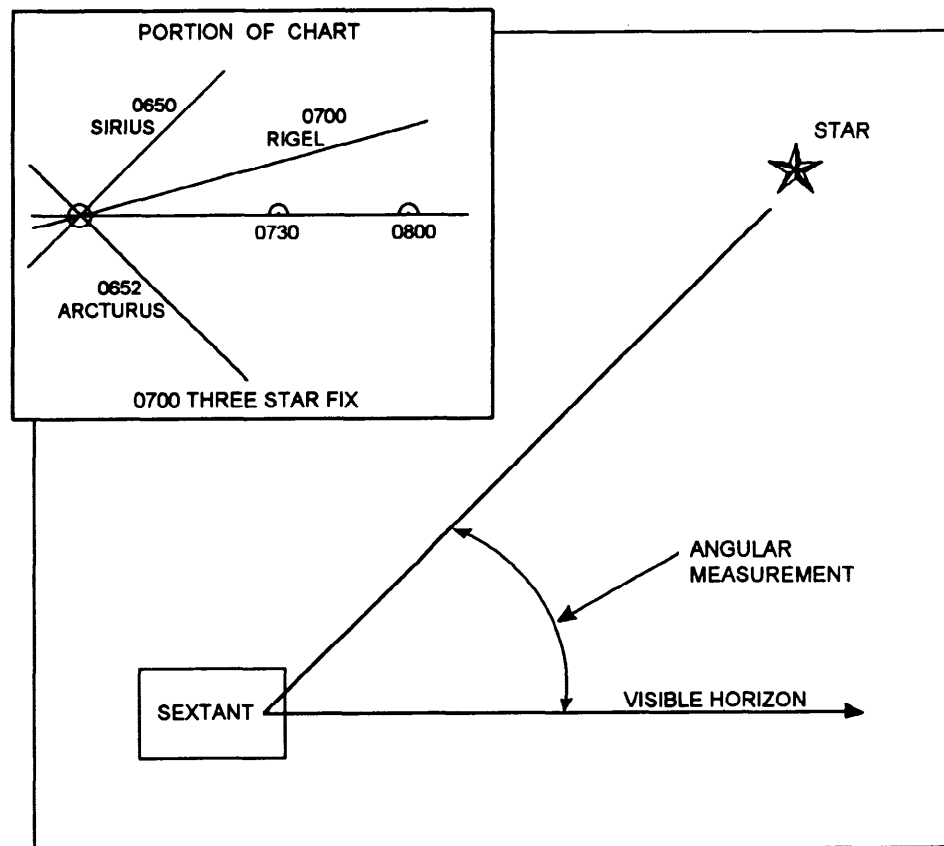

26NVJ034

Figure 1-2. Sextant angle and sample 3 star fix.

# Problems Associated with Navigation

## Information

As you have learned, navigation is an art and a science. Our early navigators experienced the same problems that face the modern navigators. There are three major problems of navigation that must always be addressed. These problems are:

- How to determine position
- How to determine the direction to get from point A to point B
- How to determine the distance between points, the time it will take, and the speed as the navigator proceeds

## Determining Position

Of the three problems facing the navigator, the most basic and also the most important is determining position. The ship's position must be known to safely and accurately direct the movements of the ship.

The term *position* refers to a known point on Earth. QMs refer to a position as a *fix*. It may also be qualified by an adjective such as *estimated* and *dead reckoned*.

## Measuring Direction

Direction is the orientation of a line drawn or imagined joining two positions without any regard to the distance between them. Direction on charts is measured in angular units using a polar coordinate system (a coordinate system based on the North Pole and South Pole). The reference used is normally *true north*.

Figure 1-3 shows a line drawn between two positions. The direction may be determined from the compass rose. Direction is measured from  $000^{\circ}$  T through  $360^{\circ}$  T.

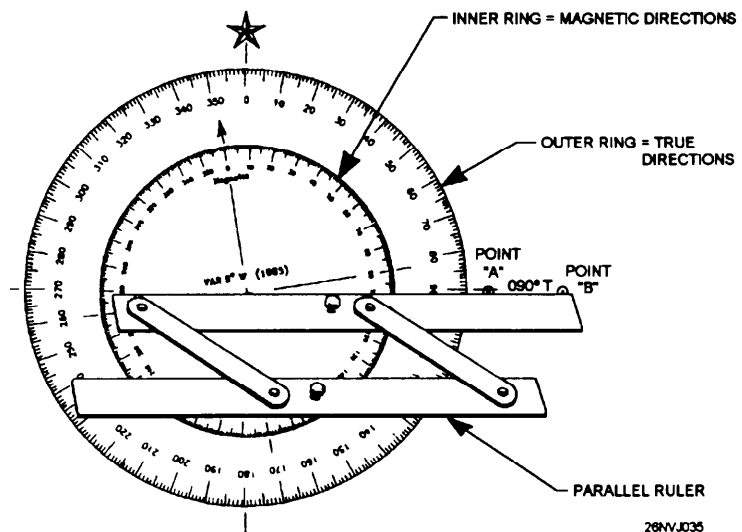

Figure 1-3. Compass rose.

## Problems Associated with Navigation, Continued

---

**Direction** Knowing the direction between two positions makes it possible for the navigator to lay a course from where he is to where he wants to go and then to proceed to that point. Direction will be presented in greater detail later in this chapter.

---

**Measuring Distance** The distance between two points is the physical separation without regard to direction. Nautical distance is measured as the international nautical mile (nmi) of 6,076.1 feet. The nmi is longer than the statute mile (mi) used on land, 5,280 feet; 1.15/1 is a simple ratio often used to convert nmi to mi.

---

**Time** Time in navigation is always based on the 24-hour clock. You are already familiar with this type of timekeeping as it is what we use in the military.

---

**Speed** Speed is defined as the rate of movement. In navigation speed is referred to as nautical miles per hours or *knots* (kn).

We can now put this all together. We have defined the major problems associated with navigation. The solutions to these problems are contained in later text. We know that the navigator **must** determine position, direction, and distance to travel. But how does speed and time figure in this picture?

---

**The Relationship Between Time, Speed, and Distance**

That brings us to the time, speed, and distance triangle. If you know the distance you need to travel and at what speed you will proceed, you can use simple mathematics to determine how long it should take to travel that distance. This is a triangle, because if you know any two values (time, speed, or distance) you can solve for the unknown value. That brings us to the next subject. Where does this information go? How does one actually go from one known position to another known position safely? The answer is the nautical chart! The remainder of this chapter will explore the nautical chart and how the QM uses it.

# Earth and the Terrestrial Coordinate System

## Background

Before we begin to examine the nautical chart, we must first understand some facts about Earth itself.

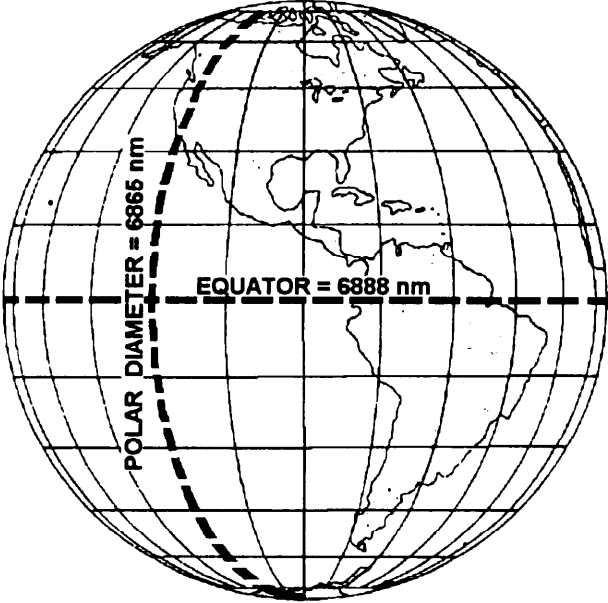
<b>Facts about Earth</b>	
	It is <b>not</b> a perfect sphere
	The diameter at the Equator equals approximately 6,888 nautical miles.
	The polar diameter is approximately 6,865 nautical miles, or 23 miles less than the diameter at the Equator.
	Technically it is classified as an oblate spheroid (a sphere flattened at the poles.)
 <p>The diagram shows a globe of Earth with a grid of latitude and longitude lines. A horizontal dashed line across the middle represents the equator, labeled 'EQUATOR = 6888 nm'. A vertical dashed line passing through the poles represents the polar diameter, labeled 'POLAR DIAMETER = 6865 nm'. The continents of North and South America are visible on the right side of the globe.</p>	
26NVJ036	
Figure 1-4. Earth.	
For the purposes of navigation, we assume that we are working with a perfect sphere. The differences between the two diameters are small enough to be considered insignificant.	
Nautical charts do NOT take Earth's oblateness into account.	



# Reference Lines on Earth

---

## Information

To locate a position on Earth's surface, you must first have some point to start from. If you imagine Earth in motion, you will notice that it spins on its axis. The axis is the imaginary line drawn between the North Pole and South Pole that forms the first point of reference. The second point of reference is the Equator, which divides Earth into two parts, the Northern Hemisphere and the Southern Hemisphere.

We now have our starting points. For practical application in locating a position, two points of reference were not adequate so we had to create great and small circles around Earth.

---

## Great Circles

A great circle is formed by a plane passing through the center of Earth. Figure 1-5 illustrates our imaginary line that connects the North Pole and South Pole. The great circle passes directly through the center of Earth, but more importantly, *around Earth's surface*. The Equator is also a great circle.

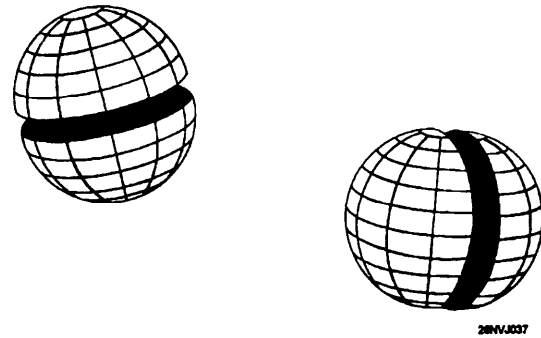

Figure 1-5. Examples of great circles.

## Small Circles

A small circle is formed by planes that do not pass through the center of Earth. Figure 1-6 illustrates several small circles. How will these circles allow us to find our position? The answer is that certain great circles and small circles have special meaning for navigation purposes. They are called parallels of latitude and meridians of longitude.

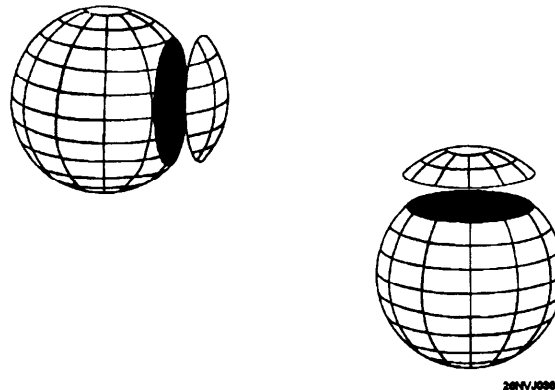
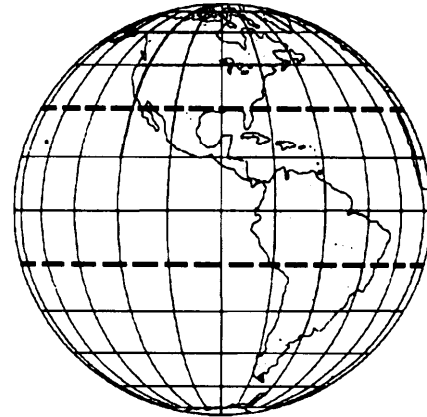

Figure 1-6. Examples of small circles.

## Reference Lines on Earth, Continued

### Parallels of Latitude

Parallels are the small circles around and on Earth's surface. For navigation, parallels of latitude have been established. They are all parallel to the plane of the Equator. Figure 1-7 illustrates parallels of latitude. Since they are all parallel to the Equator, latitude can be measured towards the North Pole and South Pole.



26NVJ039

Figure 1-7. Examples of parallels of latitude.

### How Latitude is Measured

Latitude is measured in degrees ( $^{\circ}$ ), minutes ( $'$ ), and seconds ( $''$ ) north or south of the Equator. Measurements of latitude cannot exceed  $90^{\circ}$  in either direction. This is due to the fact that the Equator is always perpendicular (at a right angle) from the great circle that forms the plane through the North Pole and South Pole.

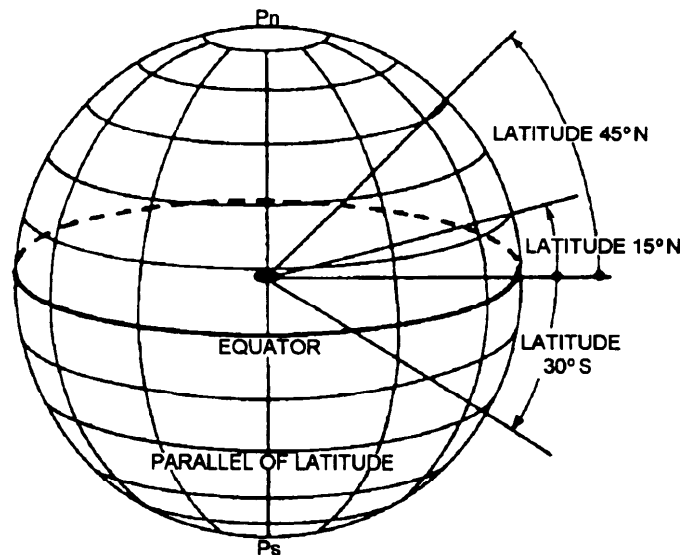

26NVJ040

Figure 1-8. Measurement of latitude.

Figure 1-8 illustrates this clearly. Do not confuse angular expressions of minutes and seconds with units of time because they are unrelated.

## Reference Lines on Earth, Continued

### Meridians of Longitude

Meridians of longitude are the great circles. They all pass through the center of Earth. The prime meridian or  $0^\circ$  of longitude is the starting point for all longitude measurements. Longitude is measured in same manner as latitude except that it is measured **east or west** throughout  $180^\circ$ . The prime meridian is also known as the Greenwich meridian. It is so named because it passes directly through Greenwich, England.

Latitude and longitude comprise the terrestrial or geographic coordinate system. Figure 1-9 illustrates how a position is located on a chart. We will discuss the mechanics of plotting a position on a nautical chart later in this chapter. Before we can do that we have to learn more about the charts we use.

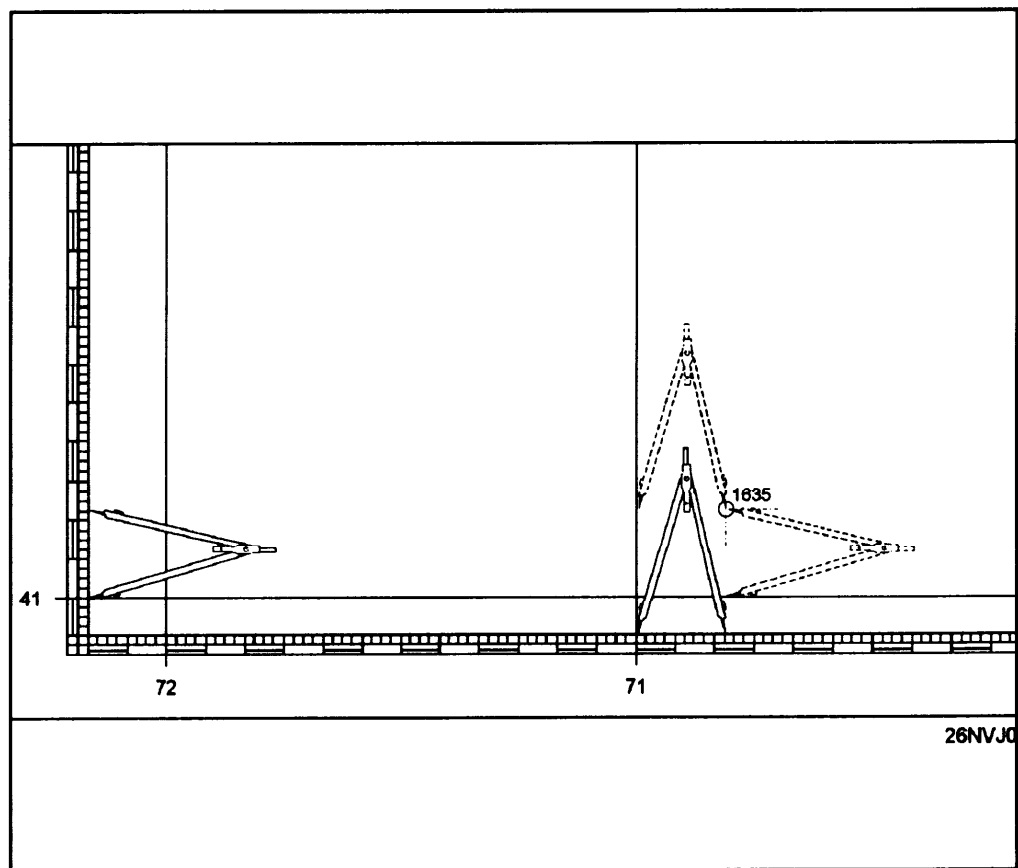

Figure 1-9. Locating a position on a nautical chart.

# The Nautical Chart

---

## Background

A nautical chart is like a road map for the world's oceans and inland waterways. The nautical chart is designed especially for navigation. A chart is a printed reproduction of Earth's surface showing a plan view of the water and land areas. It contains parallels and meridians to use when plotting a position, locating aids to navigation, and much more.

---

## Chart Projections

The task of putting the round Earth on flat paper is a complex one. This text will not go into great detail on chart projections. More information on this subject may be found in *Dutton's Navigation and Piloting*. We will discuss the two projections most widely used in today's Navy and by mariners in general.

---

## Mercator Projections

Mercator projection charts are the most commonly used navigational charts. Therefore, it is important that you understand the characteristics of these charts. The first thing to understand is that no navigational chart is perfect.

**Example:** Cut a hollow rubber ball in half and try to flatten it out, you cannot do so without tearing or stretching the rubber. In fact, no section of the hemisphere will lie flat without some amount of distortion. No system of projection has yet been devised that preserves the exact true proportions of the original sphere.

Mercator projections almost always display meridians and parallels. Meridians run from the top to the bottom of the chart, parallels run from the left to the right. Due to distortion in high latitudes, this projection rarely exceeds 70° north or south.

**Advantages:** The Mercator projection shows a rhumb line as a straight line. A rhumb line is nothing more than a compass course or direction plotted by the navigator to show that he will follow from his point of departure to his destination.

---

## Gnomonic Projections

The gnomonic projection's chief advantage is that it plots a great circle as a straight line. This is most useful when planning long ocean passages. It is always best to take the shortest route from point A to point B. This projection will be covered in greater detail in chapter 12.

# Nautical Chart Interpretation

---

## Introduction

Figure 1-10 represents a portion of an average chart. This chart contains a lot of information. When you are in doubt of a specific symbol on a chart refer to U.S. Coast Guard Chart 1 in booklet form.

Chart 1 lists all standard symbology contained on a chart and is published in easy to use booklet format. A copy of chart 1 will be available in every charthouse, if you can't find one, a copy may be found in *Dutton's Navigation and Piloting*. But a copy of Chart 1 must be ordered!

Now let's take a closer look at the chart. If you have a copy of a chart and chart 1, get them to use as references while covering this material. Use figure 1-10 on the facing pages to identify the many items that may appear on a chart.

**Note:** Figure 1-10 does not contain all symbols and features that may appear on a nautical chart! However, many items that you will work with on a day-to-day basis are called out for your attention.

# Nautical Chart Interpretation, Continued

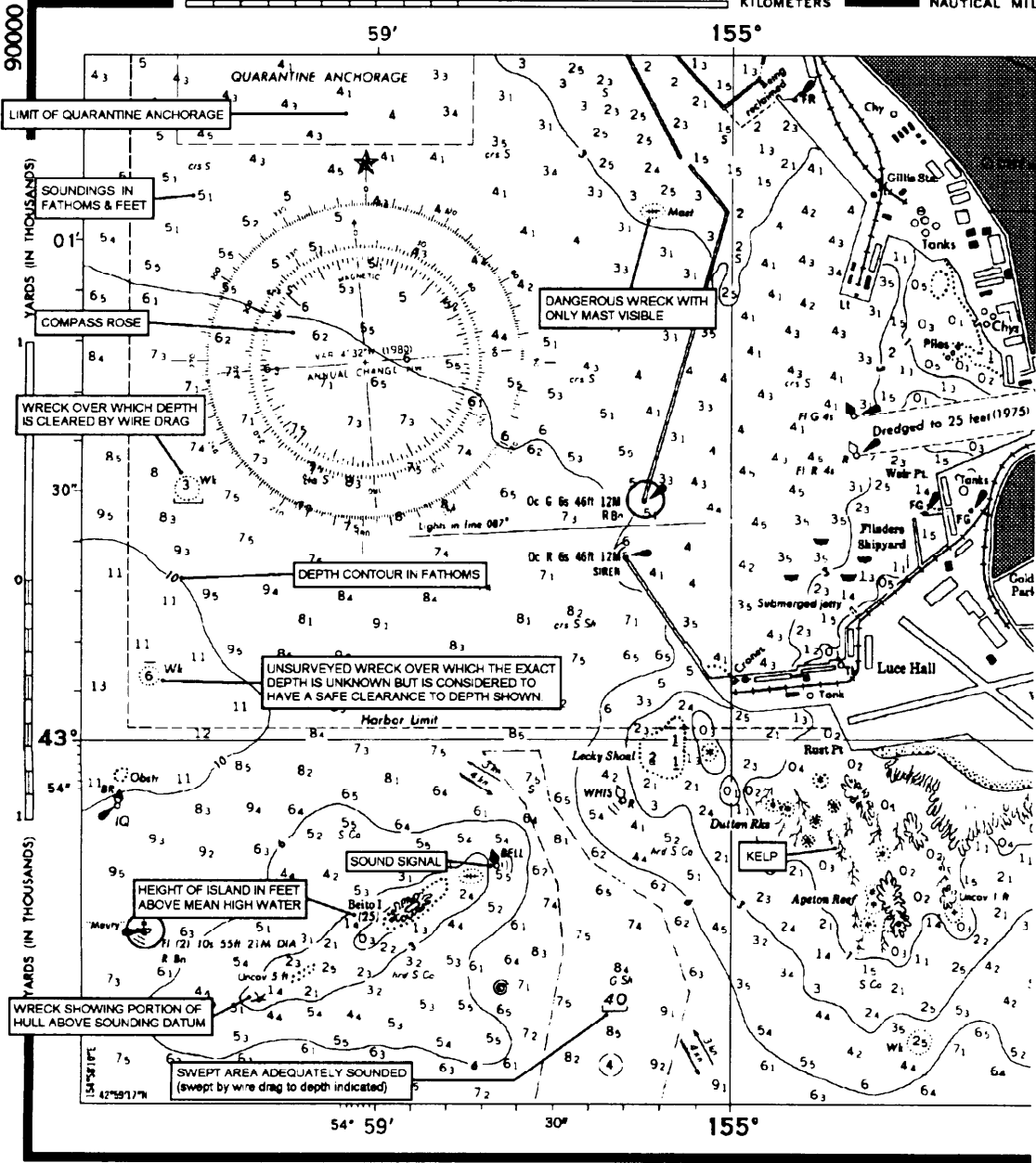

Sth. Ed. May 28, 1984 (correct through NM 21184)

Prepared and published by the DEFENSE MAPPING AGENCY HYDROGRAPHIC / TOPOGRAPHIC CENTER Washington, D.C. 20315

90000  
DMA STOCK NO  
504150000

SOUNDINGS IN FATHOMS AND FEET  
DEPTH CONTOURS IN FATHOMS

26NVJ042

Figure 1-10. Sample of a nautical chart with features called out.

# Nautical Chart Interpretation, Continued

## SOUNDINGS IN FATHOMS AND FEET

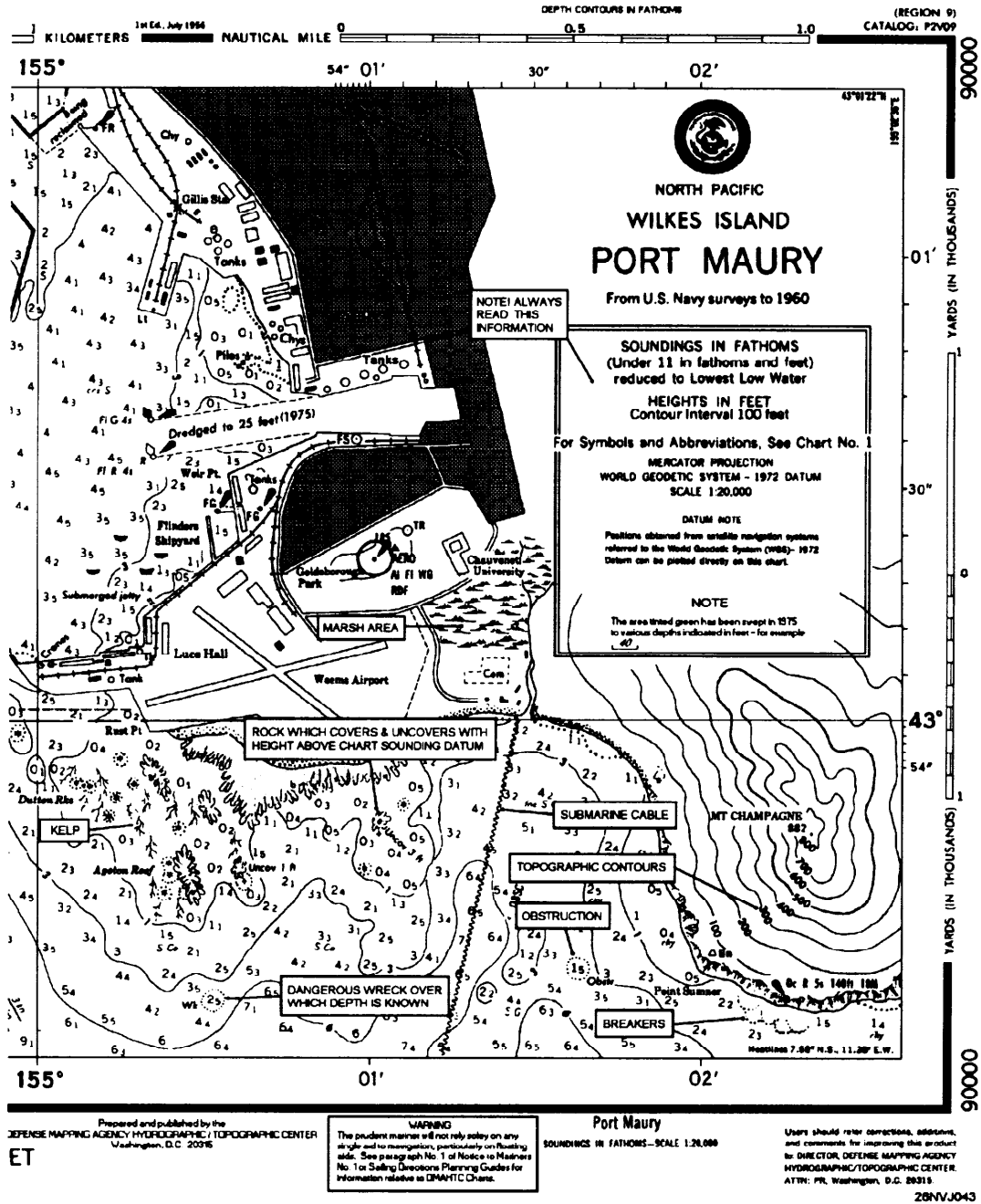

Figure 1-10. Sample of a nautical chart with features called out (continued).

# Chart Scale

## Information

The scale of a chart refers to a measurement of area, not distance. A chart covering a relatively large area is called a small-scale chart and a chart covering a relatively small area is called a large-scale chart. Scales may vary from 1: 1,200 for plans to 1: 14,000,000 for world charts. Normally, the major types of charts fall within the following scales:

Chart Type	From	To	Remarks
Harbor and Approach	1:1,000	1:50,000.	Used in harbors, anchorage areas, and the smaller waterways. Charts used for approaching more confined waters are called approach charts.
coast	1:50,000	1:150,000.	Used for inshore navigation, for entering bays and harbors of considerable width, and for navigating large inland waterways.
General and Sailing	1:150,000	1:6,000,000	Used for <b>coastal navigation</b> outside outlying reefs and shoals when the vessel is generally within sight of land or aids to navigation and its course can be directed by piloting techniques.

## Understanding Chart Scales

The size of the area portrayed by a chart varies extensively according to the scale of the chart. The larger the scale, the smaller the area represented. It follows then that large-scale charts show areas in greater detail. Many features that appear on a large-scale chart do not, in fact, show up at all on a small-scale chart of the same area.

The scale to which a chart is drawn usually appears under its title in one of two ways: 1:25,000 or 1/25,000. These figures mean that an actual feature is 25,000 times larger than its representation on the chart. Expressed another way, an inch, foot, yard, or any unit on the chart means 25,000 inches, feet, or yards on Earth's surface.

**The larger the figure indicating the proportion of the scale, the smaller the scale of the chart.** A chart with a scale of 1:25,000 is on a much larger scale, for instance, than one whose scale is 1:4,500,000.



# Chart Accuracy

---

## Information

Chart accuracy is hard to determine exactly. Several things need to be taken into consideration. The first and most important factor to consider is that a chart can be only as accurate as the survey on which it is based. To judge the accuracy and completeness of the survey, take note of its source and date. Usually, early survey dates indicate that the chart may have several irregularities. A chart must be tested before it may be used with a high degree of confidence. In heavily trafficked waters, a chart is normally quite accurate due to more thorough survey.

**Tip:** Another clue with which to determine accuracy is the abundance or absence of soundings. Infrequent soundings are an excellent indicator that the survey was not of great detail.

---

## Chart Production

Compromise is sometimes necessary in chart production, as scale, clutter, and other factors may preclude the presentation of all information collected for a given area. The National Ocean Service publishes about 1,000 charts covering in excess of 86,000 miles of shorelines. DMAHTC publishes an even greater amount.

---

## Caution

Charts are an aid to navigation and must be used with a certain amount of caution as they are not a complete guarantee of safety. Every QM team is responsible to report any changes or errors they may encounter on the charts they use. In the back of each Notice to Mariners is a form that may be filled out listing any discrepancies on charts. A radio message may also be sent to DMAHTC Attn: NTM.

# Latitude and Longitude

## Information

The latitude and longitude scales presented on the chart are broken down into whole degrees (fig. 1-11). Each degree is usually broken down into minutes on small-scale charts (remember, small scale = large area.) The large-scale chart breaks down even further into minutes (') and seconds ("). It is important that you understand these scales.

Remember that each degree ( $^{\circ}$ ) of latitude or longitude equals 60 minutes (60'), and that each minute (1') equals 60 seconds (60"). Seconds of latitude and longitude may also be expressed as a decimal fraction.

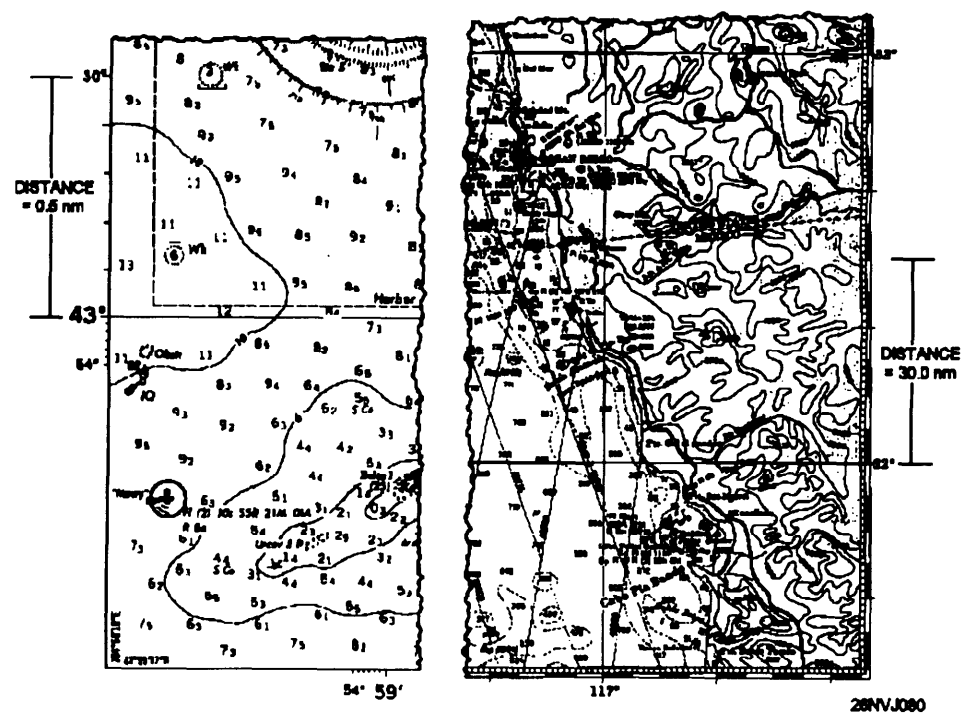

Figure 1-11. Latitude and longitude scales.

# How to Measure Distance

## Background Information

On Earth's surface, 1° of latitude may be considered 60 nautical miles in length; whereas, the length of 1° of longitude varies with latitude. Therefore, the latitude scale must be used for measuring distance. Although this scale is expanded on a Mercator chart, the expansion is exactly equal to the expansion of distance at the same latitude. Therefore, in measuring distance on a Mercator chart, one must be careful to use the latitude and longitude scale in the area one is measuring. **NEVER use the longitude scale.**

## How to Measure Distance

Use the table and figure 1-12 to learn how to measure distance on a nautical chart.

Step	Action
1.	Place one point of the dividers at the beginning of the area to be measured.
2.	Open the dividers to the desired distance to be measured.
3.	Move the dividers over to the closest latitude scale; <b>do not open or close the dividers!</b>
4.	Place one point of the dividers on a whole degree of latitude.
5.	Place the other point on the latitude scale.
6.	Determine the distance between the two points. (In figure 1-12, the measurement indicates 10 nmi.)

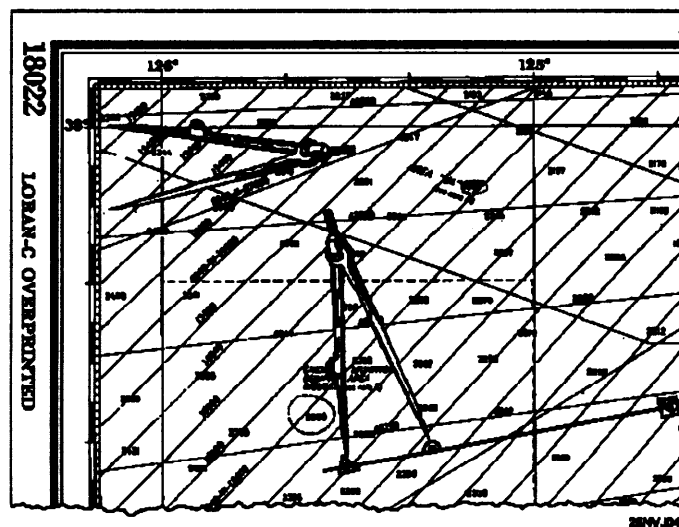

Figure 1-12. How to measure distance on a chart.

# How to Determine or Plot Direction on a Chart

## Background Information

Remember, meridians on a Mercator chart appear as straight lines, parallel to and equidistant from one another. You know they represent imaginary curved lines, not parallel to one another at all, but converging at the poles. Appearance of meridians on a Mercator projection as parallel straight lines is one of the most valuable features of this type of projection, making it possible to plot a course as a straight line (a rhumb line). On a Mercator projection, a rhumb line cuts every meridian at the same angle. In other words, it is a line of the same bearing throughout. Although it does not represent the shortest distance between the points it connects, this fact is not important unless very large distances are involved. Use the table and figure 1-13 to determine or plot direction.

Step	Action
1.	Identify the two points that you want to determine the direction to or from. Example: Pt A and Pt B.
2.	Lay one edge of the parallel rulers so that it passes through each point.
3.	Firmly press down on one side of the parallel rulers and begin to move the ruler to the compass rose.
4.	Position the ruler so either edge passes through the center crosshair of the compass rose.
5.	Use a pencil to mark the outside ring of the compass rose
6.	Read the bearing on the outside ring of the compass rose.

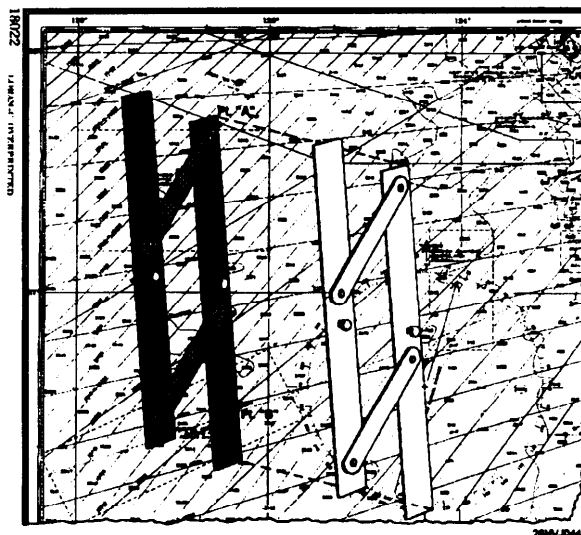

Figure 1-13. Plotting a position on a chart.

# How to Plot a Position

## How to Plot a Position

Now that we understand the latitude and longitude scales, we can learn how to plot a position. We can quickly and accurately plot any known position. Figure 1-14 will help illustrate this process. For example, a ship's position at 1800 (Lat.  $36^{\circ} 11'N$ , Long.  $70^{\circ} 17.5'W$ ) can be plotted as follows:

Step	Action
1.	Find the latitude, $36^{\circ} 11'N$ , on the latitude scale.
2.	Place the point of the compass on $36^{\circ}$ and measure up $11'$ ; now mark the scale with the compass lead.
3.	Without opening or closing the compass, move the point of the compass over to the proper meridian. In this case it is $70^{\circ}$ . Now mark the meridian with the latitude measurement.
4.	Next we will find our longitude $70^{\circ}$ and measure $17.5'$ . Care must be taken to measure towards the west or left, towards the next higher longitude. Now we will use our lead to mark off $17.5'$ .
5.	Now move the compass point up to the $36^{\circ}$ parallel and mark off $17.5'$ . Continue to move up the $70^{\text{th}}$ meridian to the point where you marked off the latitude ( $36^{\circ}11'N$ ) and mark off your longitude. You will now mark off the longitude once again, this time making a small arc.
6.	Now place the point of the compass on the $36^{\circ}$ parallel at the point where the $70^{\circ} 17.5' W$ is marked. Now mark a small arc that will cross the longitude mark. That's it, the point where the two arcs intersect is the position.

## How to Extract Latitude and Longitude from a Known Position

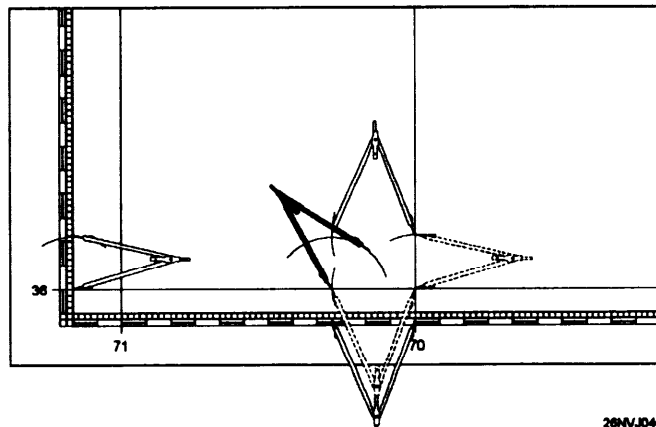

Figure 1-14. How to plot a position.

# How to Extract Latitude and Longitude from a Known Position

You have now learned how to plot a position. Now let's extract the latitude and longitude from a known position. Let's find the position of the fix labeled 1520 in figure 1-15. This is easily accomplished by following these steps:

1. Place the point of the compass directly beneath the position to be extracted on the closest parallel. Now open the compass and swing an arc that passes through the position.
2. Move your compass over to the latitude and read the latitude from the scale. Now repeat the procedure using the closest meridian as a reference.

You have now learned how to plot and extract positions on the chart. Hopefully, the previous discussion on the terrestrial coordinate system is now clear. If not, now is a good time to review the material once again. Let's continue to take a closer look at our chart, where it comes from, how it is kept up to date.

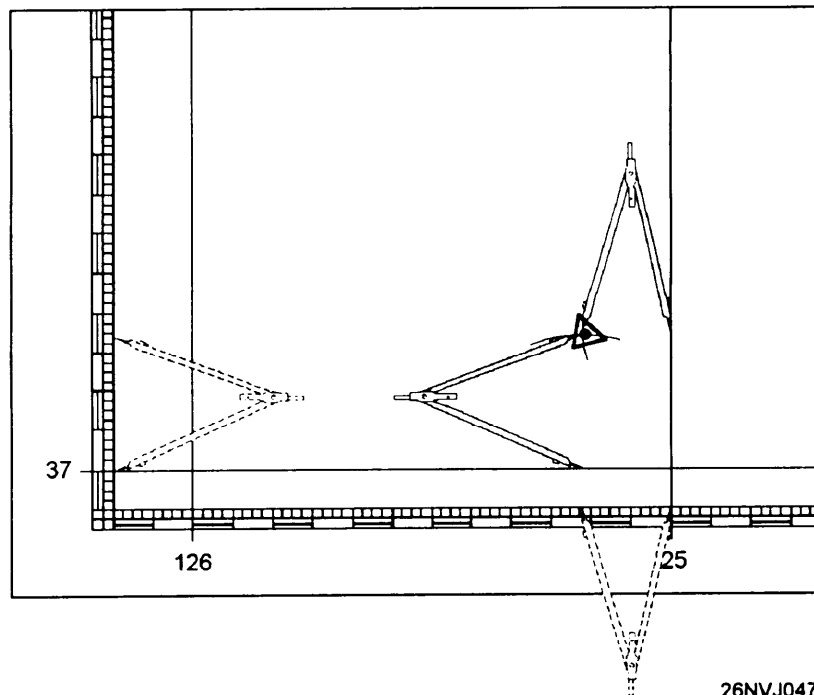

Figure 1-15. That's it, the point where the two arcs intersect is the position.

# Defense Mapping Agency

---

## Background Information

Charts used in the Navy may be prepared by the Defense Mapping Agency Hydrographic/Topographic Center (DMAHTC), the National Ocean Service (NOS), the British Admiralty, or by other hydrographic agencies. Whatever the source, all charts used by the Navy are issued by DMAHTC. In this last portion of the chapter you will learn how to determine chart coverage and select charts for any area in the world. How charts are numbered and the portfolio designations. The system used to correct charts and techniques used to make corrections. We will also discuss the chart ordering system.

---

## DMA Pub 1-N

The Defense Mapping Agency (DMA) *Catalog of Maps, Charts, and Related Products* is a four-part catalog published by the Defense Mapping Agency Office of Distribution Services (DMAODS). It provides a comprehensive reference of all DMA maps, charts, and related products available. It is organized as follows:

### PART I-AEROSPACE PRODUCTS

### PART 2-HYDROGRAPHIC PRODUCTS

Volume I United States and Canada (Region 1)

Volume II Central and South America and Antarctica (Region 2)

Volume III Western Europe, Iceland, Greenland, and the Arctic (Region 3)

Volume IV Scandinavia, Baltic, and USSR (Region 4)

Volume V Western Africa and the Mediterranean (Region 5)

Volume VI Indian Ocean (Region 6)

Volume VII Australia, Indonesia, and New Zealand (Region 7)

Volume VIII Oceania (Region 8)

Volume IX East Asia (Region 9)

Volume X Miscellaneous Charts and Publications

Volume XI (SECRET) Classified Charts and Publications (U)

Semiannual Bulletin Digest for Hydrographic Products

Monthly Bulletin for Hydrographic Products

(CONFIDENTIAL) Quarterly Bulletin for Classified Hydrographic Products (U)

### PART 3-TOPOGRAPHIC PRODUCTS

### PART 4-TARGET MATERIAL PRODUCTS

## Defense Mapping Agency , Continued

---

### Catalog

As you have seen from the organization of the DMA catalog, part 2 deals with hydrographic products. This is the only part that you will normally use as a Quartermaster. Each of the 11 volumes in part 2 contains graphic indexes and numerical listings of charts and other products.

The listings also include chart edition numbers and dates. Navigational and oceanographic publications are contained in volumes X and XI. The title and date of each publication are shown. The price is noted for each chart and publication available for sale to the public. The ordering procedures are contained in volumes X and XI.

---

### Hydrographic Bulletins

The Semiannual Bulletin Digest for Hydrographic Products is published in June and December. It provides a complete listing of all available unclassified charts and publications. The Monthly Bulletin for Hydrographic Products is issued the other 10 months between issues of the Semiannual Bulletin Digest. New and revised charts and publications issued are reported on a month-to-month basis in the Monthly Bulletin. The old edition for a chart must not be disposed of until the latest edition arrives on board.

All information reported in the Monthly Bulletin is cumulative. This means that only the latest Semiannual Bulletin Digest and Monthly Bulletin need to be held for you to have current information on all available hydrographic products. Information appearing for the first time is marked with an asterisk. The Quarterly Bulletin for Classified Hydrographic Products is published in January, July, and October, with volume XI being reissued in April. The Quarterly Bulletin provides a complete summary of all available classified charts and publications. The bulletins should be filed and used to correct your catalog volumes. They will also allow you to check and confirm that you hold the latest editions of charts and publications in your inventory and that you are not missing any charts from your required allowance. The charts listed as canceled are to be disposed of.



# DMA Stock Numbering System

## Background Information

A five-digit alphanumeric series designator prefix has been assigned to each standard nautical chart number (fig. 1-16). The purpose of this prefix is to speed up requisition processing and to improve inventory management by the DMA. It is listed in the lower left-hand corner of many charts, along with the chart edition number and date.

As illustrated in figure 1-16 the first two digits of the prefix reflect the geographical subregion in the same manner as the first two digits of the basic chart number. The third position is the portfolio assignment, A or B. X is used if the chart is not included in a portfolio. The fourth and fifth positions are alphabetical designators for the type of chart.

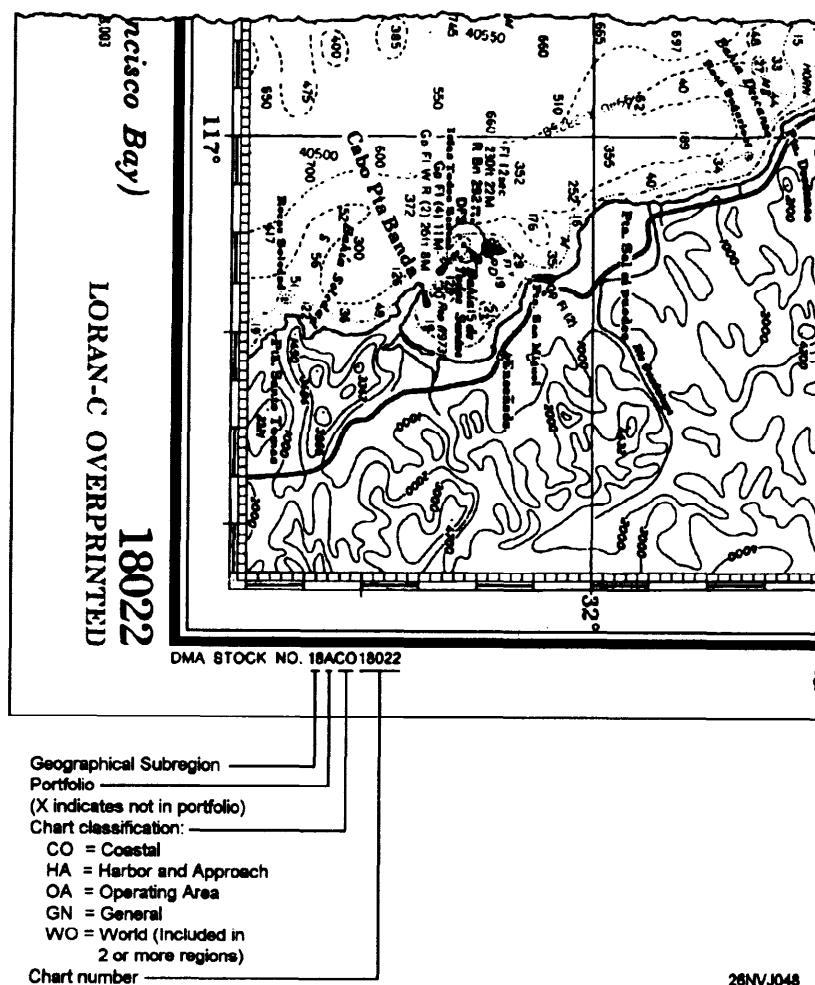

Figure 1-16. DMA stock numbering.

# The Nautical Chart Numbering System

---

## Background Information

DMA assigns a number to every nautical chart used by the U.S. Navy, regardless of the organization producing the chart. Charts produced by the NOS, and charts of foreign governments are also assigned numbers by DMA so that they may be filed in sequence with the

DMAHTC-produced charts. DMA charts have numbers consisting of **one** to **five** digits. The number of digits generally indicates the scale range, and the number itself indicates the geographical area covered by the chart. The chart numbering system is as follows:

Number of Digits	Scale	Description
1 (1-9)	None	Symbol and flag charts.
2 (10-99)	1:9,000,000 and smaller	These charts depict a major portion of an ocean basin or a large area, with the first digit identifying the ocean basin.
3 (100-999)	Between 1:2,000,000 and 1:9,000,000.	These are general charts whose numbers are based on the nine ocean basins.
4 (5000-9999)	Various	This category includes great circle tracking charts, electronic navigation system plotting charts, and special-purpose non-navigational charts and diagrams. Four-digit charts with a letter prefix (EOIOI-E8614) are bottom contour charts.

## The Nautical Chart Numbering System, Continued

---

Number of Digits	Scale	Description
5 (11000-99999)	Larger than 1:2,000,000	In this category are all standard nautical charts at a scale larger than 1:2,000,000. At scales such as this, the charts cover portions of the coastline rather than significant portions of ocean basins.
6 (800000-809999)		This category consists of combat charts and combat training charts. A random numbering system is used to prevent the identification of the geographical area covered by a classified combat chart without referring to the catalog. One reason for this is to allow you to order classified combat charts with an unclassified requisition.

---

**Note**

The five-digit category contains all the large-scale and medium-scale charts of the world. These are the primary nautical charts. The five-digit charts are based on the nine regions of the world, as shown in figure 1-15. The first of the five digits indicates the region in which the chart is depicted. The first and second digits together indicate the geographic subregion within the region, and the last three digits identify the geographic order of the chart within the subregion.

# Chart Correction System

## Background Information

The Chart/Publication Correction Record Card System is used to conserve nautical charts and publications and to reduce the amount of chart correction work aboard ship. The *Notice to Mariners*, *Local Notice to Mariners*, *Summary of Corrections*, NAVTEX and SafetyNet are considered component parts of the system.

The Chart/Publication Correction Record Card, shown in figure 1-17, is designed for use in recording all *Notice to Mariners* corrections affecting charts and publications held on board. Initially, the cards are furnished to Navy ships. Additional cards may be ordered from DMAODS. With this record, only the charts and publications of the operating area need be corrected (ready charts).

Charts and publications not immediately required for use may be updated as areas of operations change or as directed by the commanding officer. A record must be maintained for *Notice to Mariners* corrections to all charts and publications carried aboard, with actual corrections being made on all charts and publications before they are used for navigational purposes. **Never use an uncorrected chart for navigation purposes.**

CHART/PUB. CORRECTION RECORD <small>ONANC-2669/P (11-74)</small>																	
CHART/PUB. NO.		PORTFOLIO NO.		EDITION NO./DATE		CLASS	PRICE	CORRECTED THRU N. TO M. NO./YR. OR PUB. CHANGES									
90000		AHA		501 5/84		U		21/84									
TITLE Port Maury Harbor Approach																	
APPLICABLE NOTICE TO MARINERS																	
N/M	YR	PUB. PAGE NO.	CORRECTION MADE		N/M	YR	PUB. PAGE NO.	CORRECTION MADE		N/M	YR	PUB. PAGE NO.	CORRECTION MADE				
			DATE	INITIAL				DATE	INITIAL				DATE	INITIAL	DATE	INITIAL	
10	87		4/92	OS													
1	90		4/92	OS													
3	92		4/92	OS													
7	94																
CHART/PUB. NO.																	

26NVJ046

Figure 1-17. Example of a completed Chart/Publication Correction Record Card.

# Notice to Mariners

---

## Background Information

The chart and publication correction system is based on the periodical, *Notice to Mariners*, published weekly by the DMAHTC and the *Local Notice to Mariners* also published by the U.S Coast Guard weekly to inform mariners of corrections to nautical charts and publications. This periodical announces new nautical charts and publications, new editions, cancellations, and changes to nautical charts and publications. It also summarizes events of the week as they affect shipping, advises mariners of special warnings or items of general maritime interest, and includes selected accounts of unusual phenomena observed at sea. Distribution of the *Notice to Mariners* is made weekly to all U.S. Navy and Coast Guard ships and to most ships of the merchant marine.

The classified Chart and Publication Correction System is based on the *Classified Notice to Mariners*, published on an as-needed basis by the DMAHTC to inform mariners of corrections to classified nautical charts and publications.

The *Notice to Mariners* provides information specifically intended for updating the latest editions of nautical charts and publications issued by the Defense Mapping Agency, the National Ocean Service, and the U.S. Coast Guard. When the *Notice to Mariners* is received, it should be examined for information of immediate value. The list of new charts and new editions of charts and publications should also be checked to assure that the latest editions are on board.

In section I of the *Notice to Mariners*, chart corrections are listed by chart number, beginning with the lowest and progressing in sequence through each chart affected. The chart corrections are followed by publication corrections, which are also listed in numerical sequence. Since each correction pertains to a single chart or publication, the action specified applies to that particular chart or publication only. If the same correction also applies to other charts and publications, it is listed separately for each one.

Figure 1-18 illustrates the Notice to Mariners format for presenting corrective information affecting charts. A correction preceded by a star indicates that it is based on original U.S. source information. If no marking precedes the correction, the information was derived from some other source. The letter T preceding the correction indicates the information is temporary in nature, and the letter P indicates it is preliminary. Courses and bearings are given in degrees clockwise from 000° true.

# Notice to Mariners, Continued

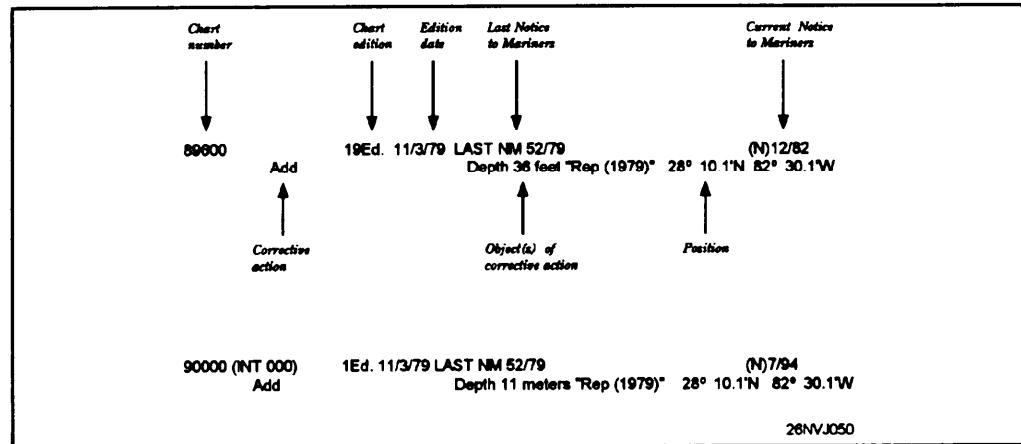

Figure 1-18. Notice to Mariners format.

## Automated Notice to Mariners System (ANTMS)

The ANTMS is used by the DMAHTC to process navigational data and to produce the *Notice to Mariners*, the *Summary of Corrections*, the *List of Lights*, and *Sailing Directions*. Your ship can query the ANTMS by message to obtain the latest navigation information while you are at sea.

For example, this could be of great importance if you have not received the most recent issues of Notice to Mariners and want to check for the latest corrections to charts you will be using to enter your next port. Instructions explaining how to gain access to the ANTMS may be obtained by writing to the DMAHTC, Attention: NVS, and requesting a copy of the Automated Notice to Mariners Communications Users Manual.

## Local Notice to Mariners

The *Local Notice to Mariners* is published weekly by the U.S. Coast Guard. It contains information of a local nature. As the U. S. Coast Guard is responsible for maintaining all U.S. Aids to Navigation, they report any changes that may have been made. This may include information such as the movement of buoys and markers, and changes in depth of the water due to dredging. It will also contain information on bridge closings, harbor restrictions, and general information concerning harbors and local coastal areas.

# Global Maritime Distress and Safety System

## Background Information

Whenever a ship is under way, it is necessary to receive information concerning any hazards in the area that the ship may be operating. Broadcast warnings fulfill this requirement. In recent years a system has been established that notifies mariners by radio messages. All messages are broken down into two categories. The first category is called *Hydros*. *Hydrolants* cover warnings in the Atlantic Ocean, *Hydropacs* cover the Pacific Ocean. The second category is called *Navareas*, which covers specific areas. *Navareas* contain information that advises mariners of operating area warnings. An example would be a navigation aid adrift. Refer to section III of the NTM for more information. Broadcast warning message boards must be updated from the weekly NTM.

## NAVTEX

To meet changing requirements and to provide better service using the latest technology, DMAHTC has worked with the Navy to provide up-to-date warning information. Thus the *NAVTEX* part of *NAVINFONET* (fig. 1-19) system has evolved and is currently going into place on all fleet units.

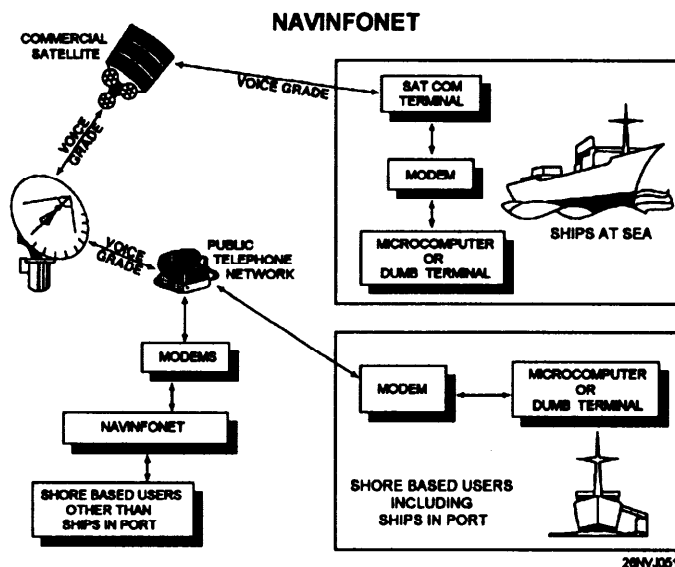

Figure 1-19. Components of GMDSS (from Pub 117).

NAXTEX will completely replace the Hydros and Navareas warnings sometime in the future. Refer to the NAVTEX receiver instruction manual for complete information.

# Summary of Corrections

## Background Information

The *Summary of Corrections* (fig. 1-20) is a six-volume cumulative summary of corrections to charts and publications previously published in the *Notice to Mariners*. The summary is used when you are correcting any chart that has not been previously corrected. For example, a chart lists twelve corrections. The summary contains all corrections through 6/93. Of the twelve corrections, ten are contained in the summary, the other two must be obtained from the applicable NTM. This saves time because instead of pulling twelve NTM, you only pull two.

## Volumes Published

DMAHTC publishes each of the five unclassified volumes semiannually and the classified volume annually. They are organized as follows:

- Volume I -East Coast of North and South America
- Volume 11 -Eastern Atlantic and Arctic Oceans including the Mediterranean Sea
- Volume III-West Coast of North and South America including Antarctica
- Volume IV-Western Pacific and Indian Ocean
- Volume V -World and Ocean Basin Charts, U.S. Coast Guard Pilots, Sailing Directions, Fleet Guides, and other Publications

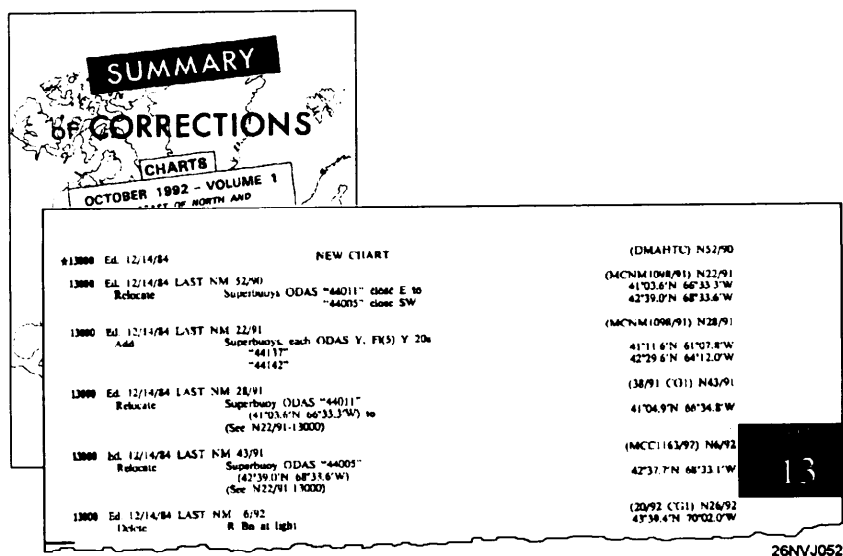

Figure 1-20. Summary of Corrections.



# Chart Card Maintenance

## Background Information

Before we can learn how to correct the charts we want to use, we need to learn the chart card system. The chart card system evolved from a need to have a standard method of recording NTM corrections. It wouldn't be practical to correct each and every chart listed in the weekly NTM. The chart card systems allows the Quartermaster to record on a card the NTM year and number for each chart in the ship's allowance as changes are made to these charts. Then the chart may be corrected as it is needed.

Illustrated in figure 1-21 are the steps to be followed to maintain the card system. These steps are generic, individual units may need to modify them to suit their needs. The following is a brief description of the steps:

Step	Action
1.	The weekly Notice to Mariners is received on board.
2.	The ready charts and any charts currently in use are checked against the NTM to see if any need correction.  <b>Example:</b> write the NTM number (4/93) on the card, and put the card(s) aside in a pile for later chart correction listed in step five
3.	Charge all affected cards. To charge cards means to enter on the card the NTM number and year. See figure 1-18. This must be done for publications also and in the same manner.
4.	Update the broadcast message boards as needed from section III of the NTM.
5.	Correct ready charts and any affected charts that may be in use as identified in step 2.
6.	Correct any publications as listed in section II.
7.	Pull (remove) all canceled charts and cards and destroy.
8.	Make cards for new charts.

# Chart Card Maintenance, Continued

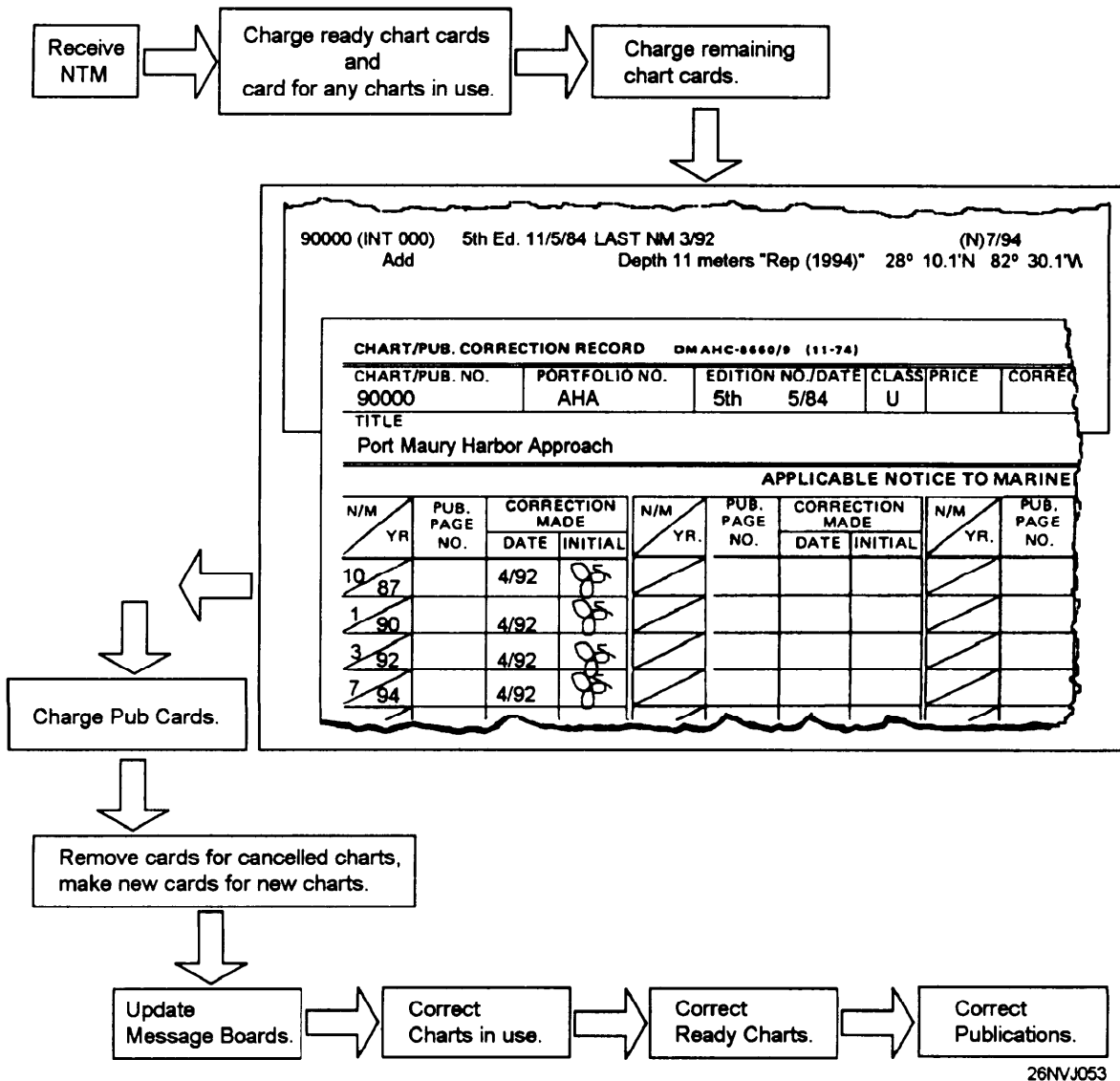

Figure 1-21. Charging the card deck.

**Note:**

When a new edition is listed in the NTM, the card must be annotated as follows: NTM 6/93 *N.E.* This indicates that a new edition is ready for issue. DO NOT DISCARD the old edition until the new one arrives.

# Chart Correction Techniques

---

## Background Information

After a little practice on obsolete charts, corrections to printed information on nautical charts can be made neatly and quickly. These corrections become a permanent part of the chart and may involve the safety of the ship. Corrections must be made in ink so they will not be accidentally erased when you are cleaning the chart after use. The only instruments necessary to correct charts are several high-quality ball-point pens or central feed technical fountain pens, a variety of stick or pencil-type erasers, and typographical correction fluid.

---

## Correction Techniques

**Example:** The NTM states that you are to add a buoy at 25°10'33"N 70°21'12"W. Locate the coordinates on the chart, determine if you need to erase part of the chart to insert the buoy. If necessary erase or use typing correction fluid (white out). **NOTE: Any information that is removed from a chart must be redrawn after the correction is made. This calls for the person effecting the correction to use some degree of judgment.**

Use the chart correction template (fig. 1-22, available from DMAHTC) to draw the buoy on the chart. Write in any information about the buoy. Chart correction may be completed in many ways. It is wise to purchase additional templates from local sources that carry drafting supplies. As a rule, corrections must always be neat and legible. Never use red ink to make corrections to a chart. The Navy uses red lighting at night. Red ink will disappear under red lights, making the correction invisible and putting the ship at risk. **DO NOT USE RED INK!**

# Chart Correction Techniques, Continued

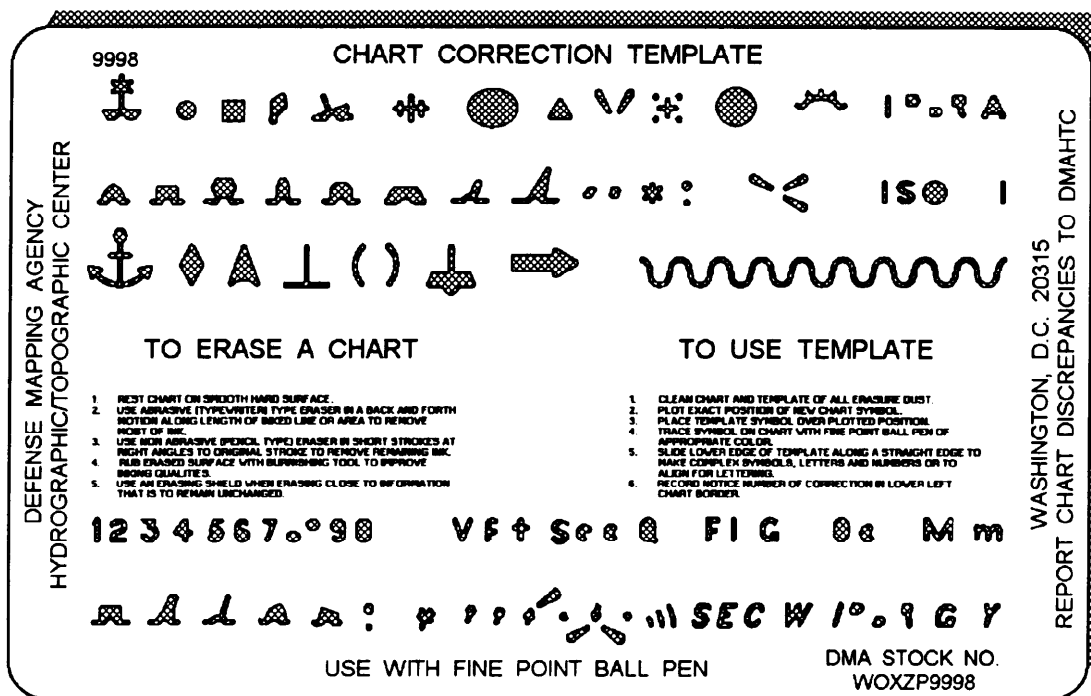

26NVJ054

Figure 1-22. Chart correction template.

## Correction Techniques

**Time Saver:** When correcting charts that have accumulated numerous corrections, it is more practical to make the latest correction first and work backwards since later corrections may cancel or alter earlier corrections. Remember to use the *Summary of Corrections*.

## Chartlet Correction

Chartlet corrections (pasters) appearing in the back of section I of the *Notice to Mariners* are to be affixed to the chart in the proper area. They must be glued in place. Any outstanding temporary changes must be transferred to the chartlet. Temporary changes in *Aids to Navigation* are not plotted by the DMA. It may be necessary to pen in lengthy notes on a chart. It is desirable to photocopy the note from the NTM and paste it on the chart whenever possible.

# Chart Ordering System

---

## Background Information

When a ship is first commissioned, it is outfitted by DMAODS with its initial allowance of charts and publications. During normal operations, some charts will wear out and requirements for additional copies of high-use charts will be established. New and revised charts and publications are received by your ship through the Automatic Initial Distribution (AID) System, which will be discussed later in this chapter.

The DMAODS issues all DMA maps, charts, and publications. A major unit of the DMAODS is its DMA Distribution Control Point (DDCP) in Washington, DC. **Submit all requisitions to DDCP. *Improper planning on your part does not constitute a crisis for local offices of DMA.* When you use a chart, always order a new chart in a timely manner.**

---

## DMA Branch Offices

The DMA offices and branch offices stock limited quantities of products to meet immediate operational needs. You may obtain products from them if time does not permit you to submit a requisition to the DDCP. When you visit a DMA office or branch office, be sure that you carry a completed requisition form with you. This form **must** be signed by the commanding officer.

---

## Chart Allowances

The basic load of maps, charts, and publications your ship is required to hold is prescribed in allowance instructions issued by your fleet commander or type commander. In some cases a ship may have a permanent allowance that is supplemented by another allowance that will cover the area to which the ship deploys. In such cases your deployment allowance is normally requested by your type commander from DMAODS about 3 months before your deployment. You should become familiar with the allowance instructions that pertain to your ship.

---

## Automatic Initial Distribution (AID)

AID refers to the automatic issue of predetermined quantities of new or revised products. AID is the means by which your ship's allowances of charts and publications is kept current with no requisitioning action required on your part. Annually the DMAODS forwards to each U.S. Navy ship on AID a computer listing, called an AID Requirements for Customer Report (R-05), to allow the command to confirm its allowance holdings. Upon receipt, an annual inventory must be conducted.

# Ordering, Labelling, and Stowing Charts

**Ordering Charts** The ordering of charts is now primarily accomplished with the help of a personal computer (PC). With the growth of computer technology, DMAHTC has written the *GETAMAP* program to aid in the ordering of charts. Complete step by step ordering procedures are contained in DMAHTC publication 1-N.

**Labelling and Stowing Charts** All charts have labelling requirements. To properly label each chart you must first fold it correctly. Start with the chart laying flat with the printed side facing up. Now fold the left side to the right side, turn the chart 90° and fold in half again. Refer to figure 1-23, note that the labelling includes a five-digit chart number, latest edition number and date, and the latest NTM that the chart is corrected through.

Charts are stowed in numerical order by regions. Care must be taken not to bend or damage charts when placing them in to the chart drawers. Several copies of the same chart should be placed inside of one copy.

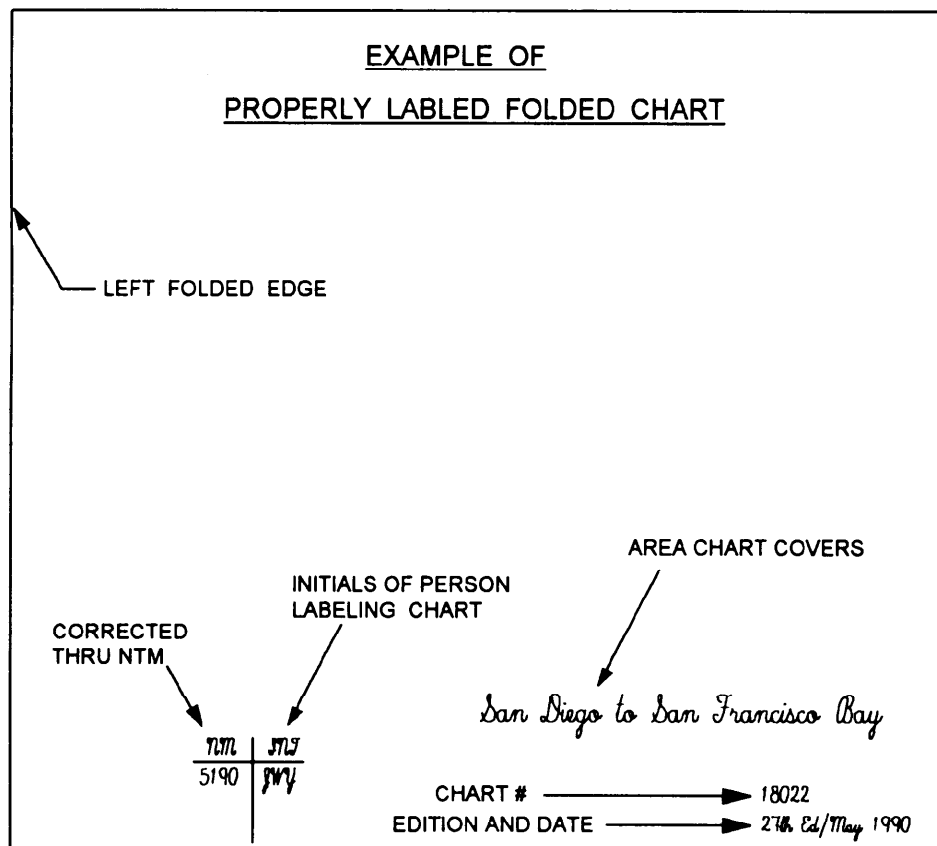

Figure 1-23. Properly folded chart.

# Chapter 2

## Compasses

---

### Introduction

The compass is the best known and most widely used of all navigational instruments. It would be almost impossible to obtain precise information on headings and directions without the compass.

There are two types of compasses in use. The *gyrocompass* is the compass that is used the most aboard ship. The *magnetic* compass is used as a backup because it requires no electricity to operate. This chapter will explain the operation and use of each type of compass and its related equipment.

---

### Objectives

The material in this chapter will enable the student to:

- Describe the components of the magnetic and gyroscopic compasses.
  - Identify and correct for compass errors.
  - Explain the procedure used to determine magnetic compass error.
  - Record entries in the Magnetic Compass Record Book.
  - Describe the process of swinging ship, conducting compass sensibility tests, and filling out the compass deviation card.
  - Determine gyrocompass error.
- 

Topic	Page
The Magnetic Compass	2-2
Earth's Magnetic Field and Magnetism	2-3
Compass components, types and operation	2-7
Magnetic Compass Error	2-9
The Shipboard Degaussing System	2-12
Magnetic Compass Record Book	2-18
Magnetic Compass Adjustment	2-19
The Gyrocompass	2-20
Tools Used to Determine and Plot Direction	2-22
Gyrocompass Error	2-23
Determine Gyro Error	2-32

# The Magnetic Compass

---

## Introduction

Before we proceed to determine the proper compass heading to steer, we must first learn about the workings of the magnetic compass.

To enable you to understand the principles, we will explore the properties of magnetism.

---

## Magnetism

Magnetism is a phenomenon of nature known only by its effects. It appears as a physical force between two objects of metal, at least one of which has been previously magnetized and has become a magnet.

---

## Definition

A magnet is a metallic element that has the property for attracting iron and producing a magnetic field around itself. For the purpose of illustration, this magnetic field is usually pictured as lines of force.

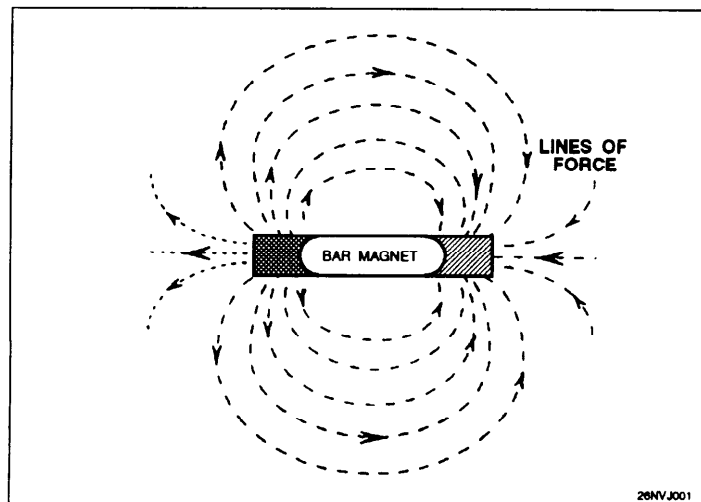

Figure 2-1. Magnetic lines of force.

---

## Types of Magnetism

There are two types of magnetism: *permanent* and *induced*. A metal bar having permanent magnetism will retain its properties when it is removed from a magnetic field.

A metal bar having induced magnetism, however, will **lose** its properties when it is removed from the same field



# Earth's Magnetic Field

---

## Introduction

Earth has magnetic properties and can be thought of as having a powerful magnet near its center (see fig. 2-2). The lines of force radiate and may be detected on the surface.

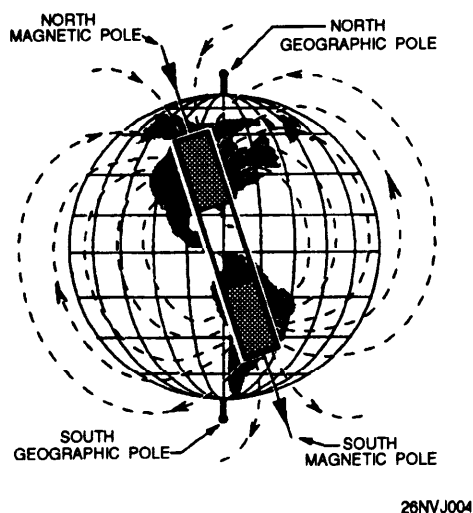

Figure 2-2. Earth's magnetic field.

This internal magnet is **not** aligned with Earth's axis. This results in the magnetic poles being in different locations than Earth's poles. At Earth's surface, lines of force become magnetic meridians having horizontal and vertical components. These components will be discussed in the next topic, Variation.

---

## Law of Magnetism

There are certain characteristics of magnetism that are important to remember. Every magnet has two poles: a north pole (blue) and a south pole (red). Each pole has opposite characteristics and they each follow the Law of Magnetism:

"OPPOSITES ATTRACT; LIKES REPEL"

A north pole attracts a south pole but it repels another north pole. This law is of importance to you because it will help you understand the relationship between the magnetic compass and the magnetic properties of Earth.

# Variation

## Information

As stated in the topic on magnetism, Earth has magnetic properties and can be thought of as having a powerful magnetic bar near its center. The lines of force appear as illustrated in figure 2-3.

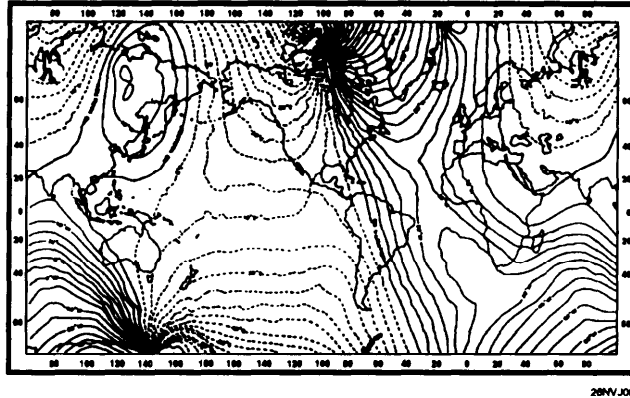

Figure 2-3. Chart No. 42 showing lines of variation.

## Facts

- Earth's magnetic properties are not uniformly distributed.
- Earth's magnetic poles are not at the same position as the geographic poles.
- Magnetic lines of force are called magnetic meridians.

The variation for any area on Earth is **always** equal to the difference between the value of true north and magnetic north.

### Example:

True north      000°

Mag. north     358°

Variation =    2° East

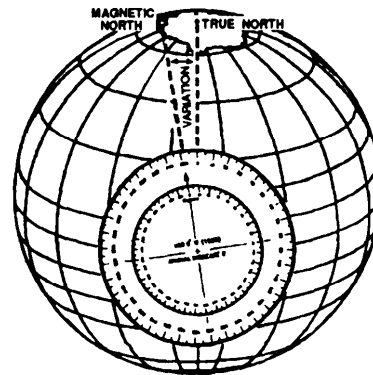

Figure 2-4. Variation equals the angular difference between true north and magnetic north.

# How to Determine Local Variation

## Background

While standing the QMOW, you will routinely be tasked with determining variation. This is a simple procedure using simple mathematics and the chart's compass rose. Use the following steps to find your local variation.

Step	Action
1.	Locate the compass rose nearest to the area in which the ship is operating.
2.	Locate the variation and annual increase/decrease from the center.
3.	Locate the year from the center of the compass rose.
4.	Subtract the year indicated from the current year.
5.	Multiply the number of years times the annual change.
6.	Add the sum (or subtract if decreasing) from step No. 5 to the variation in the center of the compass rose.
7.	Round the total off to the closest $\frac{1}{2}^\circ$ .

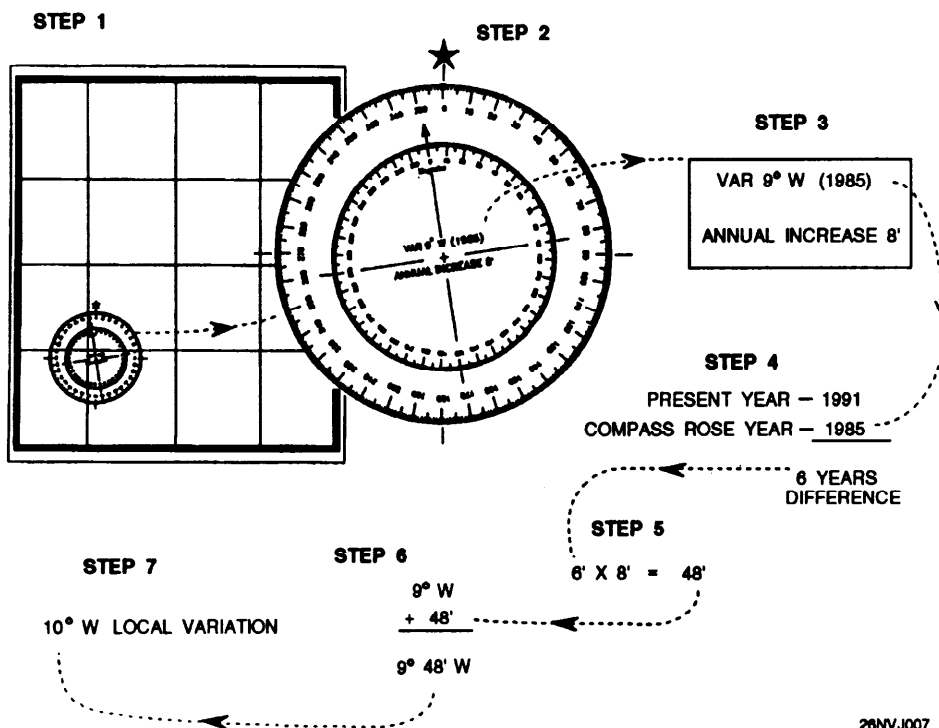

26NVJ007

Figure 2-5. Steps followed to determine variation.

## Standard and Steering Compasses

---

### Compasses are REQUIRED

The Chief of Naval Operations requires that each self-propelled ship and service craft of the United States Navy be equipped with one or more magnetic compasses suitable for navigation.

Except for modern nuclear-powered submarines, all ships and craft, regardless of size or classification, must have a magnetic steering compass at the primary steering station.

---

### Steering Compass

Many ships carry more than one magnetic compass. The primary magnetic compass is called the *steering compass*. It is normally located on the centerline in the ship's pilothouse (except aboard aircraft carriers), where it can best be seen by the helmsman. The readings from the steering compass are labeled "*per steering compass*" (*PSTGC*).

---

### Standard Compass

If a ship has two magnetic compasses, the second compass is called the *standard compass*. The ship's standard compass is normally located on the ship's centerline at the secondary conning station. The readings from the standard compass are expressed as "*per standard compass*" (*PSC*).

---

### Note

The readings from the ship's gyrocompass are "*per gyrocompass*" (*PGC*). Courses and bearings by these compasses must be carefully differentiated by the abbreviations.

---

### Cautions

A magnetic compass cannot be expected to give reliable service unless it is properly installed and protected from disturbing magnetic influences. Certain precautions must be observed in the vicinity of the magnetic compass.

- If possible, a compass should not be placed near iron or steel equipment that will be moved frequently. Thus, a location near a gun, boat davit, or boat crane is not desirable.
- The immediate vicinity should be kept free of sources of magnetism, particularly those of a changing nature.
- When possible, no source of magnetism should be permitted within a radius of several feet of the magnetic compass.

# Magnetic Compass Operation and Components

## Operation

The operation of a magnetic compass is very simple and can be stated as follows: *"A small bar magnet freely suspended in the magnetic field of Earth will always align itself parallel to the lines of force of that field and thus will establish a direction."*

## Components

Use the following table, figure 2-6, and figure 2-7 to learn the parts of a magnetic compass.

Part	Function
Card	The card is an aluminum disk graduated in degrees from 0 to 359. It has a jeweled bearing that rides on a hard, sharp pivot point.
Bowl	The card is supported by the bowl. A lubbers line is marked on the bowl and is used as visible index. The bowl is filled with Varsol to dampen overswings by the card. An expansion bellows in the lower bowl serves to allow expansion of the liquid with temperature changes.
Magnets	Several bar magnets are used to correct and align the compass.
Gimbals	The bowl has two pivots that rest in a metal ring, which also has two pivots resting in the binnacle. This arrangement (gimbals) permits the compass to remain level despite the motion of the ship.
Binnacle	<p>The binnacle serves as a housing for the compass. It is made of a non-magnetic material. It also serves as a housing for the compass correctors:</p> <ul style="list-style-type: none"> <li>magnets, flinders bar, and quadrantal spheres. A lighting system is normally installed.</li> </ul> <div style="text-align: right;">  <p>The diagram shows a cross-section of a compass binnacle. At the top, there are two black spheres labeled 'QUADRANTAL SPHERES (HORIZONTAL SOFT IRON CORRECTORS)'. Below them is a 'HOOD' over the 'COMPASS BOWL'. Inside the bowl, there is a 'FINDER'S BAR (VERTICAL SOFT IRON CORRECTORS)' and 'ATHWARTSHIP CORRECTORS' at the bottom. 'FORE AND AFT CORRECTORS' are also indicated near the base of the bowl.</p> </div>

Figure 2-6. Compass binnacle

# Magnetic Compass Operation and Components, Continued

## Components

The following illustrations should help you visualize the working parts of a basic magnetic compass.

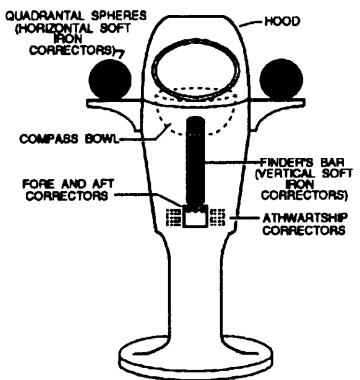
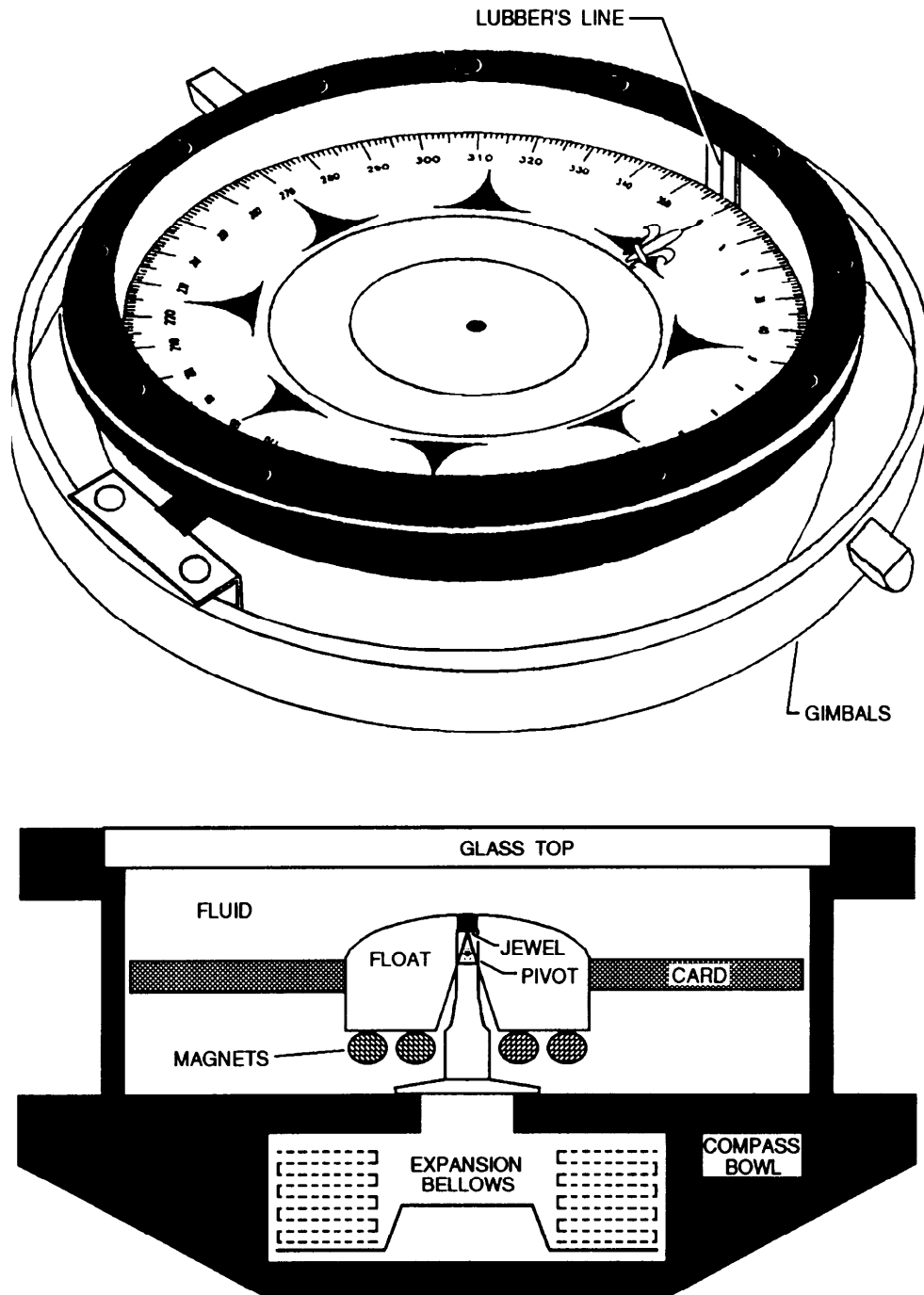

26NVJ002

Figure 2-7. Parts of a magnetic compass.

# Magnetic Compass Error

---

**Introduction** Before we use a magnetic compass aboard a ship, we must first correct for the magnetic influences that make the compass deviate from true or geographic north.

The first influence is **variation**, which we have already covered. The second is **deviation**.

---

**Deviation** Deviation may be defined as the amount that the compass is deflected from the magnetic meridian because of the effects of the ship's iron. This is where **permanent** and **induced** magnetism come in to play.

---

**Permanent Magnetism** Also known as hard-iron magnetism, permanent magnetism is created in the ship's structure during the building process. The ship's structure gains its own unique magnetic field based on the angle that the keel was laid.

---

**Induced Magnetism** Also known as soft-iron magnetism, induced magnetism varies according to the intensity of the component of Earth's field in which it was induced.

---

**Compass Error** The amount of deviation **varies** as the ship changes course. The ship's magnetic effects may be corrected by the proper placement of various correctors.

The **process** of correcting for deviation error is called **swinging ship**. The navigator and QM gang will swing the ship through 360 degrees, stopping each 15 degrees and comparing the compass heading against a properly functioning gyrocompass. The results are recorded on the magnetic compass deviation table.

**Example:** While swinging ship and steady on course 015° by gyro, the magnetic compass reads 016°. It should read 015°; the 1° difference is the amount of deviation. In this case, it is labeled westerly deviation 1.0° W.

---

**Next** The next topic deals with the magnetic compass deviation table. From there we will look at degaussing, and then you will learn how to perform compass calculations to correct for variation and deviation.

# Magnetic Compass Deviation Tables

## Purpose

The purpose of the magnetic compass deviation tables, commonly referred to as "deviation tables," is to provide a means of knowing the deviation of the magnetic compass for any heading. This information is crucial to safe navigation if the gyrocompass fails.

## Table Composition

The figure on the right is an example of a deviation table. The top portion of the table contains the name of the ship, location of the compass (pilot house), binnacle type, and compass type.

The middle section of the table contains the ship's heading and deviation data.

**Example:** You want to steer course 090° magnetic. By inspecting the table for ship's heading 090°, you'll notice that the deviation is equal to 1.0° West with DG OFF (DG is an abbreviation for degaussing) and 1.5° West with DG ON. To make good 090°, you would have to actually steer course 091°.

The bottom portion of the table contains information on magnet and flinders bar placement that corrects for excessive deviations.

MAGNETIC COMPASS TABLE					
SHIPS HEAD MAGNETIC		DEVIATIONS		SHIPS HEAD MAGNETIC	
		DG OFF	DG ON		
0		1.5W	0.0	180	0.0 0.5E
15		0.5W	0.5E	195	0.5E 1.5E
30		0.0	1.0E	210	1.5E 2.0E
45		0.0	0.5E	225	2.5E 2.5E
60		0.0	0.0	240	3.0E 3.0E
75		0.5W	0.5W	255	2.5E 2.5E
90		1.0W	1.5W	270	1.5E 1.0E
105		2.0W	2.0W	285	0.0 0.0
120		3.0W	1.5W	300	0.5W 1.0W
135		2.5W	0.5W	315	2.0W 1.5W
150		2.0W	0.5W	330	2.5W 1.0W
165		1.0W	0.0	345	2.0W 0.5W

U. S. S. CLEVELAND NO. LPD-7  
 PILOT HOUSE  SECONDARY CORNING STATION  OTHER \_\_\_\_\_  
 BINNACLE TYPE:  NAVY STD  OTHER \_\_\_\_\_  
 COMPASS 7 1/2" MAKE LIONEL SERIAL NO. 13613  
 TYPE COILS K DATE 19 SEP 1984  
 READ INSTRUCTIONS ON BACK BEFORE STARTING ADJUSTMENT

DEVIATIONS DETERMINED BY  SUNS AZIMUTH  GYRO  SHORE BEARINGS  
 B 2-4" MAGNETS RED  FORE AT 15 " FROM COMPASS CARD  
 AFT  
 C 0 MAGNETS RED  PORT AT \_\_\_\_\_ " FROM COMPASS CARD  
 STBD  
 D 2-5"  SPHERES AT 12 " ATHWART-SHIP 0 °  CLOCKWISE  
 CYLS  SLEWED  CTRL CLKWISE  
 HEELING MAGNET  RED UP 13.6 " FROM COMPASS CARD FLINDERS BAR  FORE 12 "  
 BLUE UP  AFT  
 LAT 23° 24' North  LONG 130 39' East  
 M  Z

SIGNED (Adjuster or Navigator) R. E. FERGUSON APPROVED (Commanding) J. B. RIDGE CAPT USN

Figure 2-8. Magnetic compass deviation table.



# How to Determine Deviation

## Information

As you learned in the last topic, the deviation tables contain information on the deviation for headings. The deviation table must be updated annually and posted on or near the magnetic compass. Follow the steps in the step action table to determine the deviation and magnetic course to steer.

**Example:** Refer to figure 2-8. Your ship is on course 090° T, the gyro fails and the OOD now wishes to make good course 117° (magnetic course) by magnetic compass. Find the proper deviation from the magnetic compass deviation table and recommend the correct magnetic course to steer to make 117° good. In this example we will assume that degaussing is turned OFF.

DETERMINING YOUR DEVIATION								
Step	Action	Example/Result						
1.	Determine if degaussing is ON or OFF  <table border="0" style="margin-left: 40px;"> <tr> <td style="border-bottom: 1px solid black;">If</td> <td style="border-bottom: 1px solid black;">Then</td> </tr> <tr> <td>OFF</td> <td>Use left column</td> </tr> <tr> <td>ON</td> <td>Use right column</td> </tr> </table>	If	Then	OFF	Use left column	ON	Use right column	OFF
If	Then							
OFF	Use left column							
ON	Use right column							
2.	In the deviation table, locate the course nearest your desired course.	The nearest course is 120						
3.	Read the deviation	Deviation equals 3.0 W						
4.	Apply the deviation correction to the ordered course	<p>RULE: Westerly deviation means that the compass reads less than it should. You must add W deviation to the magnetic course.</p> <p>Easterly deviation is opposite, you must subtract the deviation from the magnetic course to get your course to steer or "compass course."</p> <table border="0" style="margin-left: 40px;"> <tr> <td>Magnetic Course</td> <td style="text-align: right;">117°</td> </tr> <tr> <td>Deviation</td> <td style="text-align: right;">+ 3° W</td> </tr> <tr> <td>Compass Course</td> <td style="text-align: right; border-top: 1px solid black;">120°</td> </tr> </table> <p>Because of the compass deviation you must steer compass course 120° to make magnetic course 117° good.</p>	Magnetic Course	117°	Deviation	+ 3° W	Compass Course	120°
Magnetic Course	117°							
Deviation	+ 3° W							
Compass Course	120°							

# The Shipboard Degaussing System

---

## Purpose

When a ship is close to a magnetic mine or magnetic torpedo, the magnetic field of the ship actuates the firing mechanism and causes the mine or torpedo to explode. Degaussing is an electrical installation designed to protect ships against magnetic mines and torpedoes. The purpose of degaussing is to counteract the ship's magnetic field and establish a condition such that the magnetic field near the ship is, as nearly as possible, just the same as if the ship were not there.

---

## Components

Shipboard degaussing installation consists of permanently installed degaussing coils, a control unit to control the coil current, and compass compensating equipment to prevent disturbances to the magnetic compasses by the magnetic field of the degaussing coils. Figure 2-9 illustrates the types of coils that are found on a typical degaussing installation.

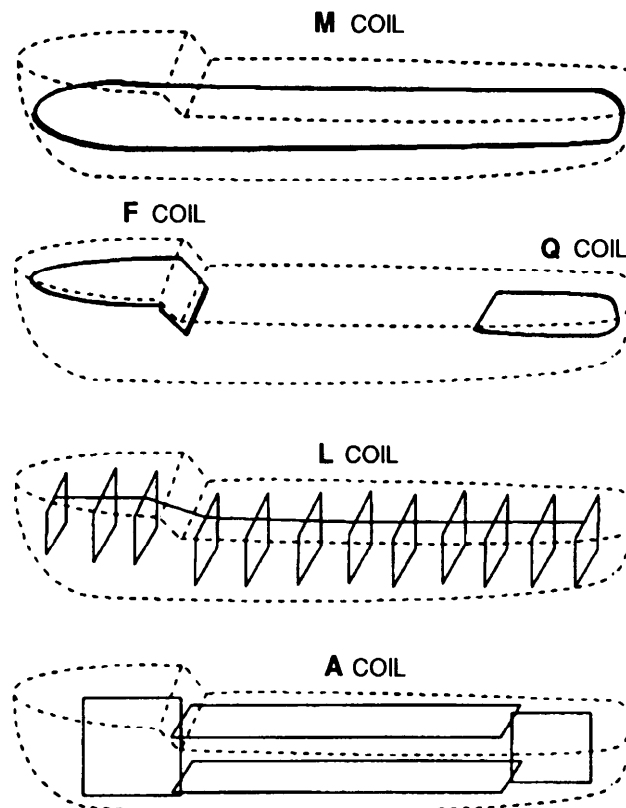

Figure 2-9. Typical degaussing coil layout.

## The Shipboard Degaussing System, Continued

---

**Degaussing Coils** The degaussing coil is actually a large diameter electrical wire. As you might have guessed, when it is energized it produces an electromagnetic field.

The following table gives a description of each coil and its effect on the ship's magnetic field.

<b>Coil</b>	<b>Description</b>
<b>A</b>	The A, or athwartship, coil is made up of loops in vertical fore-and-aft planes. The function of the A coil is to produce a magnetic field that will counteract the ship's athwartship permanent and induced magnetism.
<b>F</b>	The F, or forecastle, coil encircles the up to the forward 1/3 of the ship. It is usually located just below the forecastle or uppermost deck. The function of the F coil is to produce a magnetic field that will counteract the ship's longitudinal permanent and induced magnetism.
<b>L</b>	The L, or longitudinal coil is made up of loops in vertical planes parallel to the ship's frames. The function of the L coil is to produce a magnetic field that will counteract the ship's longitudinal permanent and induced magnetism.
<b>Q</b>	The Q, or quarterdeck, coil encircles the after 1/3 of a ship. It serves the same purpose as the F coil.
<b>M</b>	The M, or main, coil encircles the ship in a horizontal plane, usually just below the waterline. The function of the M coil is to produce a magnetic field that will counteract the ship's vertical permanent and induced magnetism.

---

### **Degaussing and the Magnetic Compass**

The deviation to the magnetic compass resulting from these currents is neutralized as much as possible by a procedure called compensation. The remaining deviations caused by the degaussing coils are observed and plotted on the left side of the deviation table.

# Compass Error Calculations

---

## Background

In navigational work, you have to develop the ability to quickly and accurately convert directions between true, magnetic, and compass (headings, courses, and bearings).

A heading or course is the same as an angle. It is the angle that the centerline of the ship or boat, or a line marked on a chart makes with some other reference line.

---

## Reference

Three lines of reference have been established: the direction of true north, or the true meridian; the direction of magnetic meridian; and the direction of the north point of the compass. Ship's heading is the same. How you describe it depends on the reference point used.

There are three ways to name a course or heading:

- True heading
- Magnetic heading
- Compass heading

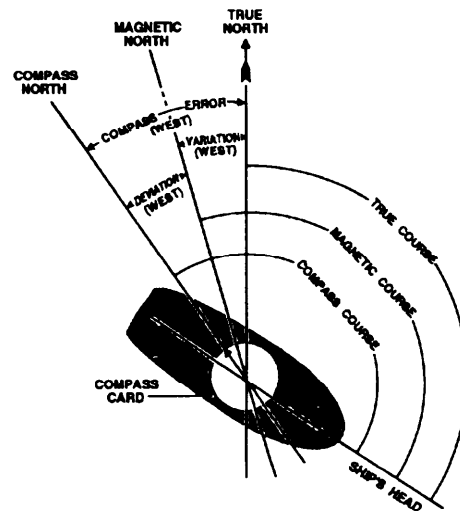

---

## Comment

Whether you are determining courses the helmsman is to steer, obtaining bearings to be plotted on a chart, laying track lines on the chart, or recording courses in the Magnetic Compass Record Book, knowing how to apply variation and deviation comes into play. The big question is "how do we convert one to the other?" Practice is needed to perform this task. However, keep in mind that you first need to reason each step, until later when the process becomes habit.

# Memory-Aids

## Information

There are several sets of "memory-aids" available to assist you in performing compass calculations. The following simple phrases are designed to assist you in remembering how to convert from one heading expression to another and how to name errors.

Memory Aid Set 1		Memory Aid Set 2	
Can	= Compass	Timely	= True
Dead	= Deviation	Vessels	= Variation
Men	= Magnetic	Make	= Magnetic
Vote	= Variation	Distance	= Deviation
Twice	= True	Count	= Compass
At	= Add	At	= Add
Elections	= Easterly D and V	War	= Westerly D and V
If the Compass is Best the Error is West.		If the Compass is Least the Error is East.	

## Meanings

The first set of aids were designed to help you remember the arrangement of the first letters of each word in the phrase. These are arranged representing the three ways of naming a direction (compass, magnetic, true) with the respective differences (deviation and variation) properly placed between them: (CDMVT) compass, deviation, magnetic, variation, true. The first letters in the words *at elections* stand for add east (subtract west), when converting the direction from compass to true. When converting in the opposite direction, the letters are reversed (TVMDC) and the memory aid "timely vessels make distance count at war" informs us to add west (subtract east) error when converting from true to compass.

The second set of memory aids deal with comparison of two compass headings to determine whether to call the difference east or west. If the comparison is between magnetic and compass, and compass is a greater number (best), the difference is west. The same comparison can be made between true and magnetic. In this case, magnetic is considered the same as compass.

Correcting: converting from compass course to a true course

Uncorrecting: converting from a true course to a compass course

# How to Perform Compass Calculations

---

## Performing Calculations

The following table will allow you to visualize the steps necessary to perform compass calculations. The table is followed by several example exercises that should be completed before you move on to additional material.

Step	Action
1.	Write down the first letters from the phrase "Can Dead Men Vote Twice."
2.	Ordered course is 180°T; you want to find the compass course to steer. You already know what T is, so write it down.
3.	Let's say that the corrected variation from the center of the compass rose is 11°E.
4.	When uncorrecting, remember that you add westerly errors and subtract easterly errors. The variation is easterly, so subtract it from the true heading to find the magnetic heading.
5.	Next, from the deviation table, figure 2-8, find the value closest to 169°, interpolating as necessary; write it down.
6.	Remember, when uncorrecting you add westerly errors. $15 + 169 = 184$ .

---

## Closing

Now you can see that to head 180° true, you must steer 184° by this particular magnetic compass. In this example, we were uncorrecting (changing from true to compass). We could have used the same method to change from compass to true; but we must remember that when correcting, we add easterly and subtract westerly errors. With an understanding of these rules, we can now go on to applying the lessons learned to a functional part of a Quartermaster's job—recording entries in the Magnetic Compass Record Book. But first, complete the training examples on the next page.

# Exercises

---

**Instructions** Now that you have been shown how to perform calculations using the magnetic compass and its error, you need to practice these skills. The following problems give you one or more values; you are to fill in the blanks with the correct answer. Take your time and refer back to previous material to complete each exercise.

**Exercise 1** Find the missing values.

<b>C</b>	<b>D</b>	<b>M</b>	<b>V</b>	<b>T</b>
022	4E	026	6W	

<b>C</b>	<b>D</b>	<b>M</b>	<b>V</b>	<b>T</b>
090	1.5W		3E	

<b>C</b>	<b>D</b>	<b>M</b>	<b>V</b>	<b>T</b>
210	1.5E			220

<b>C</b>	<b>D</b>	<b>M</b>	<b>V</b>	<b>T</b>
328		325		332

**Exercise 2** Using the memory-aids "Compass Best, Error West" and "Compass Least, Error East," fill in the missing values.

<b>Compass Course</b>	<b>Actual Compass Reading</b>	<b>Error</b>
180	182	2W
225	229	
196	193	

<b>True Course</b>	<b>Actual Gyro Reading</b>	<b>Error</b>
339	337	
196	194.5	

## Practical Application

### Compass Comparison

Whenever a ship is under way it is necessary to compare the ship's compasses to make sure that they are operating properly. This is accomplished by using the compass calculations and checking the compasses against the true course.

### Example

The following table represents an excerpt from the Magnetic Compass Record Book.

Date	Time	Latitude	Longitude	Gyro Compasses				True Heading
				---- Gyro	-----Gyro			
				Gyro Reading	Error	Gyro Reading	Error	
10Mar94	1000	36°24 W	74°12 W	120	1.0E			121
	1012	36 04 W	074 14 W	270	1.0E			271
	1025	36 05 W	074 18 W	297	1.0E			

In this example the date, time, latitude, and longitude of the observation are noted. The master gyro is reading 120; the error determined by the morning azimuth is 1.0 E. Remember, if the compass is least the error is east; you would add the error to obtain the true heading. Knowing our true heading, we can now apply our variation and compare the magnetic compasses.

Variation	Magnetic Heading	Magnetic Compasses				DG ON/OFF	REMARKS
		Standard		Steering			
		Compass Reading	Dev	Compass Reading	Dev		
14 W	135	136	1W	134	1E	OFF	
14 W	285	289	4W	283	2E	OFF	Energized degaussing at 1022
14.5W		313		311		ON	

As you can see, this is the practical application of your newly acquired compass calculation skills. Practice by filling in the blanks for the 1025 entry. When under way, the compasses must be compared every one-half hour and at each course change.

**Note:** There is an exception; if a ship is in a formation and changing course frequently, or the ship is alongside another ship, each course change does not need to be recorded. Use the following statement in the Remarks column: "Steering various courses while alongside (in formation)." A comparison must still be made every one-half hour!



# Magnetic Compass Adjustment

---

## Background

The magnetic compass must be adjusted at least once a year. The process of adjustment is called "swinging ship." This is required as a safety precaution; also as the ship steams, its magnetic properties will change.

The process of swinging ship is too detailed and complicated to be completely taught within this training manual. As the magnetic compass is considered a piece of equipment, it is covered by the Planned Maintenance System (PMS). Training on compass adjustment is normally done by OJT.

---

## Basics

The following table lists the basic steps to be followed to adjust a magnetic compass. *It cannot be used solely as a guide for compass adjustment.*

**Rule:** When performing actual adjustment, you must use the PMS card and publication 226.

Step	Action
1.	Meet with the navigator to schedule PMS.
2.	Twenty-four hours prior, inform QM gang of intentions.
3.	Four hours prior review MRC; gather all tools.
4.	Four hours prior, calculate the true courses to steer.
5.	Man all stations and begin swinging ship.
6.	Fill out a new magnetic compass deviation table.
7.	Have the new table signed by the commanding officer.

---

## Closing

The process of swinging ship is often tedious and very time consuming. In most cases a minimum of 4 hours should be set aside for this task. It is not advisable to attempt to adjust a compass in moderate to heavy weather. Doing so will often render the results inaccurate.

---

## ANSWERS

EX 1; 020; 088.5, 091.5; 211.5, 8.5 E; 3.0 W, 7.0 E.  
EX 2; 4.0 W, 3.0 E, 2.0 E, 1.5 E.

# The Gyrocompass

---

## Introduction

The gyrocompass was developed as the answer to the need for an instrument that would indicate TRUE NORTH rather than MAGNETIC NORTH. The gyrocompass is now the main source for determining direction.

---

## Operation

The basis for the gyrocompass is the **gyroscope**. A rapidly spinning body having three axes of angular freedom constitutes a gyroscope. This may be illustrated by the heavy wheel rotating at high speed in supporting rings or gimbals.

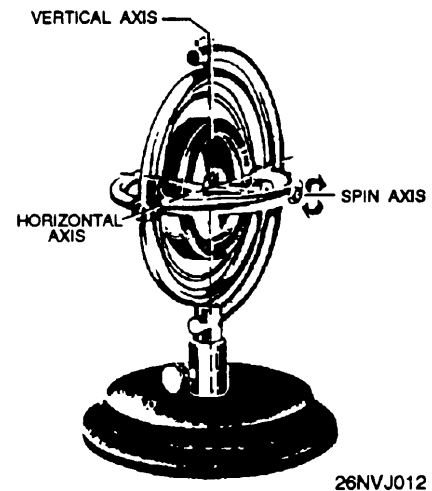

The gyrocompass must be lit off a minimum of 4 hours prior to use. This allows the gyro to warm up and settle. It is desirable to lite off the gyrocompass 24 hours prior to the scheduled underway time.

Figure 2-11. Gyroscope.

---

## Components

The gyrocompass is powered by electricity and consists of two main components. They are the *master gyro* and *repeaters*. The master gyrocompass consists of a control cabinet, power supply, speed unit, alarm unit, and transmission units. It is normally located within the ship's hull where it is least affected by pitch, roll, yaw, and battle damage. The IC electricians are responsible for its upkeep.

---

## Accuracy

A properly functioning gyrocompass will often have a mechanical error of 2° or less. The gyrocompass must be checked for error at least once daily while the ship is under way.

# Repeaters

## Purpose

Repeaters are designed to receive the signal transmitted from the master gyro. This allows the ship's control stations to receive real-time gyro data. The chief advantage of repeaters is that they may be set up nearly vertical for use by the helmsman. Repeaters may also be placed flat for taking bearings of nav aids or ships with alidades and bearing circles.

Figure 2-12 illustrates a standard repeater. The card is laid out with relative bearings on the outside circle and true bearings on the inside circle. In upcoming topics you will learn how to use related tools to measure angles (bearings) using repeaters.

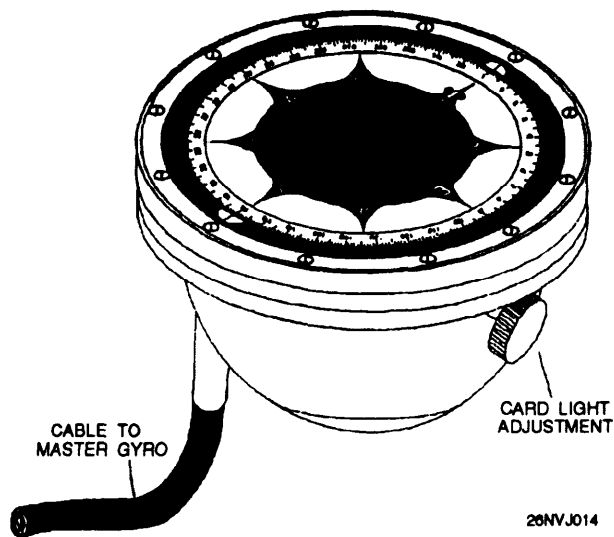

Figure 2-12. Standard gyro repeater.

## Locations

Repeaters are normally found at all the ship's control stations, these areas include but are not limited to the following spaces:

- The pilothouse and bridgewings
- Aftersteering
- Secondary conn

Additional repeaters are normally placed in the following spaces:

- Commanding officer's stateroom
- CIC
- Navigator's stateroom

## Accuracy

The QMOW must check the repeaters occasionally against the master gyro to determine errors.

## Tools Used to Measure Direction

### Introduction

The QM uses several pieces of navigational equipment to determine direction. Remember that direction may be labeled in many ways, such as course, *azimuth angle*, *bearing*... . The following table contains information about tools and their uses.

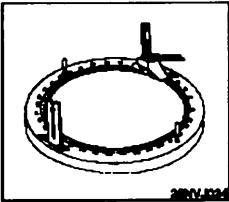
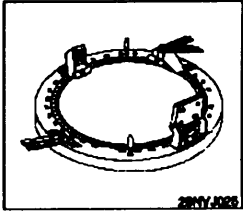
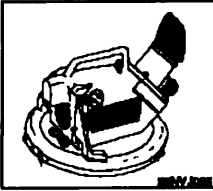
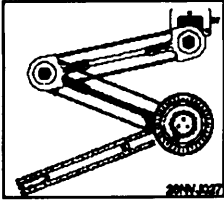
Tool	Most often used...
<p><b>Bearing Circle</b></p>	<p>to obtain the bearings of other ships to determine relative motion</p> <p>also to find the bearing of any object.</p> 
<p><b>Azimuth Circle</b></p>	<p>to obtain an azimuth of the Sun for checking gyrocompass error</p> <p>also as a bearing circle.</p> 
<p><b>Telescopic Alidade</b></p>	<p>to obtain bearings of aids to navigation to determine the ship's position</p> <p>also to obtain data for <sup>1</sup>amplitudes for checking gyrocompass error.</p> 
<p><b>Parallel Motion Protractor (PMP)</b></p>	<p>to determine and plot bearings and courses on charts</p> 

<sup>1</sup> Obtaining an amplitude is a method of checking the error of the gyrocompass. An amplitude is normally taken of the Sun rising or falling, but it may be used for any celestial body.

# Gyrocompass Error

---

## Introduction

The gyrocompass is normally the main reference for direction for the surface navigator. When properly used, serviced, and maintained, the modern gyrocompass is extremely accurate. However, as is the case with all electronic instruments, it is subject to error and damage.

One power failure or other casualty can render the entire system useless. All naval ships are equipped with gyro failure alarms. The alarms sound when a loss of power is experienced. It is during this time that the magnetic compass comes into play. As you learned earlier, the magnetic compass does not require electricity to operate. It's always ready for use by the navigator.

---

## Errors

Most normally functioning gyrocompasses will not have an error of more than  $2.0^\circ$ . More often than not, the error is between  $0.0^\circ$  and  $0.5^\circ$ .

**Rule:** When at sea, the Quartermaster **must** determine the gyrocompass error *at least once a day*. However, the prudent navigator will take advantage of every opportunity to check the accuracy of a gyro.

There are many methods of checking the accuracy of a gyrocompass. The following methods are commonly used on U.S. Navy ships:

- Terrestrial range
- Trial and error (Franklin technique)
- Azimuth of the Sun
- Amplitude of the Sun

The first two methods are used only when a ship is near land. They use aids to navigation and geographic locations shown on a chart for reference. The last two methods are used when the ship is at sea, and they use the Sun as a reference.

---

## Next

Before we learn these methods, we have to learn how to use the bearing circle, alidade, and PMP. They play a large part in the first two methods. The last two methods use celestial navigation methods to determine error and will be discussed in length in the Celestial Navigation chapter.

# Bearing Circle and Azimuth Circle

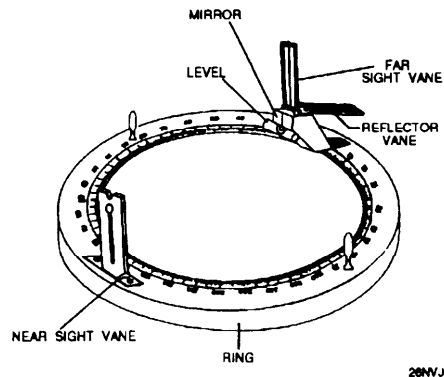

Figure 2-13. Parts of a bearing circle.

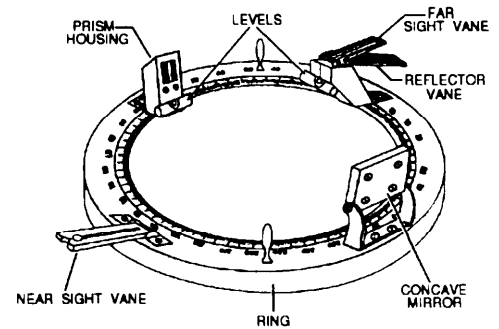

Figure 2-14. Parts of an azimuth circle.

## Components

Figure 2-13 is a diagram of a bearing circle and figure 2-14 is a diagram of an azimuth circle. The table below lists the major parts and functions of each of these circles.

Part	Bearing Circle	Azimuth Circle	Function
Ring	Yes	Yes	Fits upon a 7 ½ inch gyro repeater.
Sight Vanes	Yes	Yes	Allow the observer to take bearings of objects by aligning the two vanes to the object. The near vane contains a peep sight while the far vane contains a vertical wire. The far vane is mounted on top of a housing that contains a reflective mirror inside enabling the observer to read the bearing from the reflected portion of the compass card.
Reflector Vanes	Yes	Yes	Allow the observer to observe azimuths of celestial bodies (stars and planets) at various altitudes by picking up their reflection in the black mirror. When the body is observed, its reflection appears behind the vertical wire in the far vane.
Levels	Yes	Yes	Indicate if the ring is level with the horizon. <b>NOTE:</b> Bearings read when the ring is not level are inaccurate.
Concave Mirror	NO	Yes	Reflects the Sun's rays onto the prism housing on the other side of the ring when the observer is taking an azimuth of the Sun.
Prism Housing	NO	Yes	Directs the beam of light from the concave mirror downward in a narrow beam onto the compass card enabling the observer to read the azimuth to the Sun.

## How to Use a Bearing Circle

---

Follow the steps in the table to properly obtain a bearing.

<b>Step</b>	<b>Action</b>
1.	Place the ring on top of the repeater, then gently twist the handles to lock in place.
2.	Orient the bearing circle with the peep sight nearest to you and the far vane closest to the object to be sighted.
3.	Look through the peep sight and view the object inside the far vane.
4.	Rotate the bearing circle left or right to align the vertical wire in the far vane with the center of the object.
5.	Keep the bearing circle level by observing the spirit level.
6.	When the object is in line with the peep sight and wire, observe the bearing reflected from the mirror in the housing from the compass card.
7.	Determine which compass mark is aligned with the crosshair seen in the mirror, and read the bearing.

---

### Note

Information concerning how to use the azimuth circle will be presented in the Celestial Navigation chapter.

# Parallel Motion Protractor (PMP)

## Introduction

The PMP is a valuable tool for plotting direction quickly and accurately. When in restricted waters and plotting fixes every 3 minutes, you will greatly appreciate this instrument. The PMP is usually anchored to the top of the chart table.

The PMP is designed to keep the moveable compass rose oriented to the longitude and latitude of any chart. An arm is attached to the moveable compass rose which can be rotated to whatever bearing you require and then moved to the object on the chart that the bearing was taken to, so an LOP can be drawn.

Part	Description of function
Anchor plate	Allows the PMP to be attached to the chart table.
Friction control knob	Allows adjustment of movement of the arms at the two linkage points.
Bearing scale	A 360° circle marked in 1° increments. When locked it will maintain its orientation when moved around the chart table.
Index marks	Used to align the ruler on the desired bearing. The four marks spaced every 90° are inscribed on a plate that is directly linked to the handle and the ruler.
Protractor lock switch	Locks the bearing scale when aligning the PMP.
Scale lock switch	Locks the PMP ruler on a desired bearing.

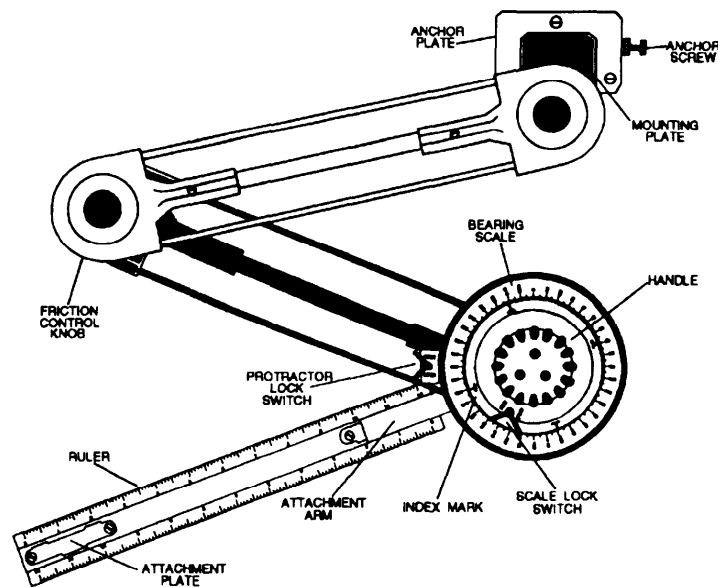

28NVJ020

Figure 2-15. Parts of a PMP.



## How to Set Up the PMP

### Note

The PMP is normally set up to automatically compensate for gyrocompass error. The error may be "dialed in"; this allows the LOPs and course lines to be plotted without correction.

Follow these steps to set up the PMP. See figures 2-16 and 2-17 on the next page to see what the scale looks like with 0° gyro error and also with gyro error dialed in.

Step	Action								
1.	Tape the chart you are using onto the chart table by its comers.								
2.	Take the PMP out of its storage box.								
3.	Place the mounting plate inside the anchor plate and tighten the anchor screw to secure the PMP to the chart table.								
4.	Attach the ruler to the PMP by placing the ruler on the table and sliding it into the attachment arm.								
5.	Unlock both the protractor and the scale locks.								
6.	Twist the handle to align the ruler with the latitude line on the chart.								
7.	Rotate the bearing scale to the appropriate position. <table border="1" data-bbox="639 1100 1346 1411"> <thead> <tr> <th>IF gyro error is...</th> <th>THEN align the scale . . .</th> </tr> </thead> <tbody> <tr> <td>Zero</td> <td>To the 0° index mark</td> </tr> <tr> <td>Westerly</td> <td>To the index mark on the scale to the left of zero, equal to the amount of gyro error</td> </tr> <tr> <td>Easterly</td> <td>To the index mark on the scale to the right of zero, equal to the amount of gyro error</td> </tr> </tbody> </table>	IF gyro error is...	THEN align the scale . . .	Zero	To the 0° index mark	Westerly	To the index mark on the scale to the left of zero, equal to the amount of gyro error	Easterly	To the index mark on the scale to the right of zero, equal to the amount of gyro error
IF gyro error is...	THEN align the scale . . .								
Zero	To the 0° index mark								
Westerly	To the index mark on the scale to the left of zero, equal to the amount of gyro error								
Easterly	To the index mark on the scale to the right of zero, equal to the amount of gyro error								
8.	Lock the bearing scale using the protractor lock switch.								

# How to Set Up the PMP, Continued

## How to Align with 0° Error

Figure 2-16 illustrates how the PMP looks when it is aligned with no gyro error. The ruler is aligned on any parallel (latitude line) and the scale lock is released, the moveable compass rose is aligned as shown and the scale lock is tightened. The PMP is now aligned to true north and is ready to plot LOPs or courses.

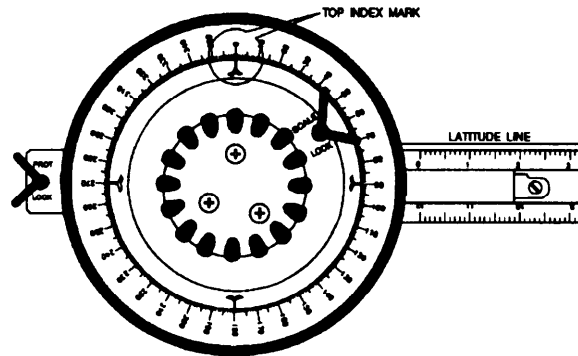

28NVJ021

Figure 2-16. PMP dialed in with 0° gyro error.

## Aligning the PMP with Gyro Error

Figure 2-17 illustrates how the PMP looks when aligned with 30° W or 2° E gyro error. The ruler is aligned on any parallel (latitude line) and the scale lock is released, the moveable compass rose is aligned as shown, and the scale lock is tightened.

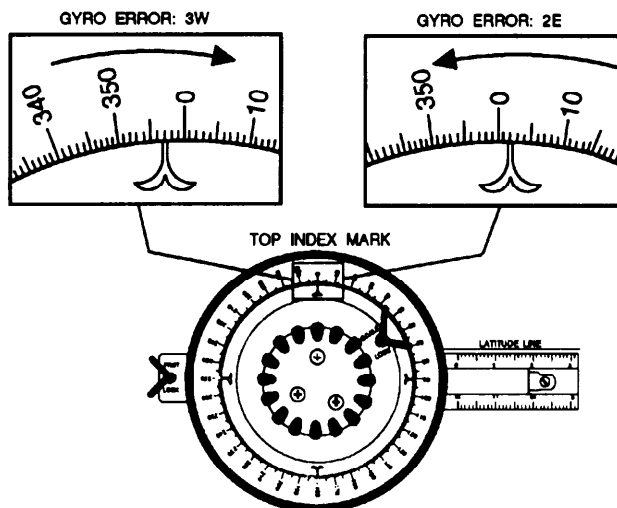

28NVJ022

Figure 2-17. PMP dialed in with gyro error.

## How to Plot With a PMP

With the PMP properly aligned, its easy to use the tool to plot bearings or lay out course lines. Use the following steps and figure 2-18 to plot with a PMP.

Step	Action
1.	Locate the index mark closest to the ruler.
2.	Rotate the handle, which moves the index mark and ruler, so the index mark points to the bearing you want to plot.
3.	Maintain the index mark in that position by either locking the scale lock switch or holding the bearing scale and index mark plate tightly with your thumb and forefinger.
4.	Move the ruler to the charted object that you took a bearing to.
5.	Draw the line of position on the chart.

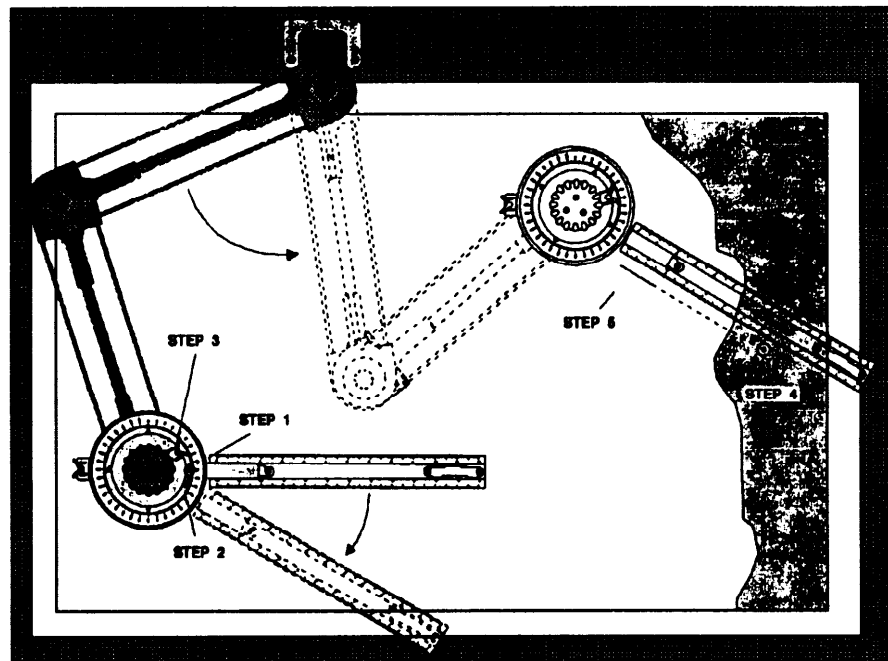

26NVJ023

Figure 2-18. How to plot with a PMP.

# Telescopic Alidade

## Parts and Functions

The following are the parts and functions of the telescopic alidade shown in figure 2-19.

Part	Description of Function
Ring	Fits upon a 7½ inch gyro repeater.
Light filter knob	Enables the observer to switch to an internal light filter, which protects your eye from the brightness of the Sun.
Polarizing adjustment knob	Enables the observer to adjust the light filter from light to dark, depending on the brightness of the Sun.
Level	Indicates if the ring is level with the horizon. Bearings read when the circle is not level are <b>NOT ACCURATE!</b>
Focus knob	Enables the observer to adjust the internal telescope lens so the view is focused.

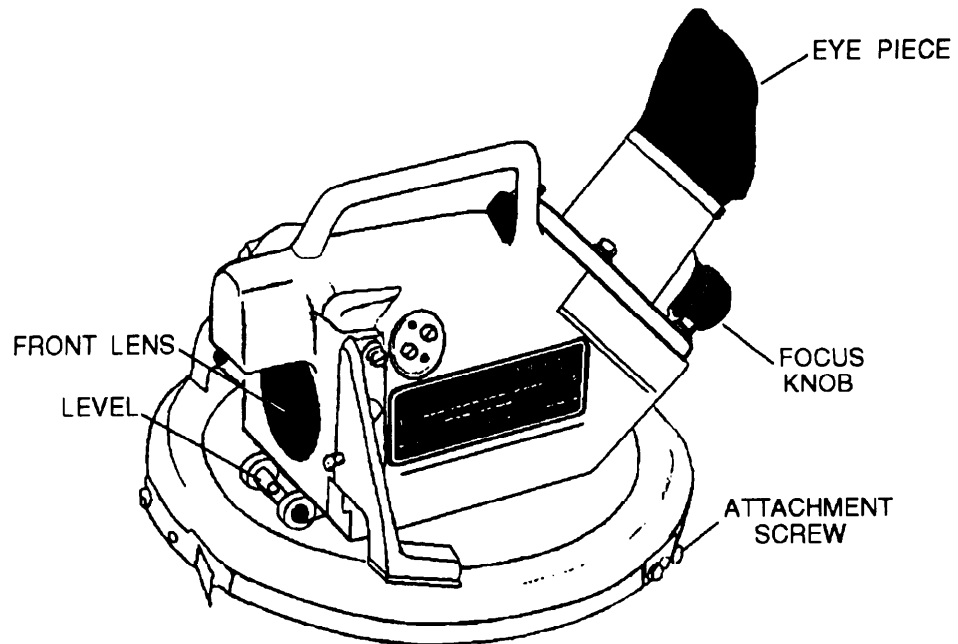

26NVJ019

Figure 2-19. Telescopic alidade.

# How to Use the Telescopic Alidade

## View Through the Alidade

The optical system simultaneously projects the image of the compass card, together with a view of the spirit level, onto the optical view of the telescope. By this means, both the object and its bearing can be viewed at the same time through the alidade eyepiece.

Figure 2-20 illustrates taking a visual bearing with a telescopic alidade. In this example, the bearing to the lighthouse is 022°.

Follow these steps to properly take a bearing with a telescopic alidade.

Step	Action
1.	Place the ring on top of the gyro repeater and twist locks into
2.	Point the front lens of the alidade towards the object to be sighted. Tip: Sight along the handle to quickly find an object.
3.	Look into the eyepiece and rotate the alidade right or left until the object is aligned with the crosshair.
4.	Keep the alidade level by observing the spirit level in the top part of the view.
5.	With the object lined up and level, read the bearing from the reflected compass card. Read the inside compass card for true bearings.

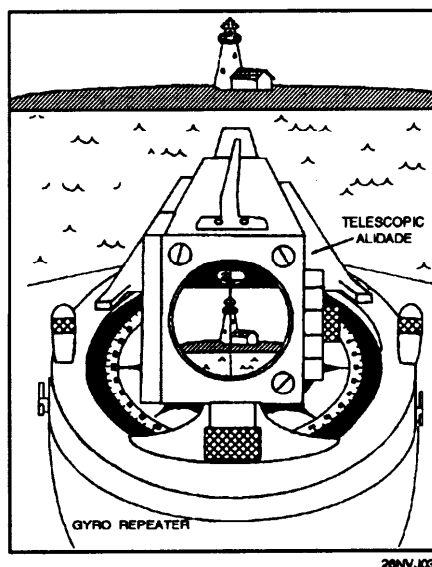
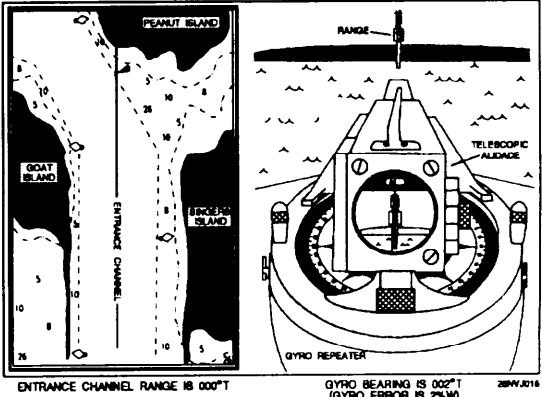

Figure 2-20. View through an alidade.

# Determining Gyro Error by Terrestrial Range

## Background

An excellent opportunity to check the accuracy of the gyrocompass presents itself each time a ship enters or departs port. Most harbors will have at least one set of range markers set. This method of checking a gyrocompass is often referred to as obtaining a *range of opportunity*. To determine gyro error by terrestrial range, you should follow the steps in the table and refer to figure 2-21.

Step	Action
1.	View the range markers through the alidade.
2.	The ship maneuvers "on range" (range markers are in line.)
3.	"Shoot" (take) a bearing on the range markers while they are lined up.
4.	<p>Compare the bearing taken against the chart.</p>  <p>Figure 2-21. Determining gyro error by terrestrial range.</p>

## Tip

It is also possible to mark a range as it passes down the port or starboard side of the ship. The steps in the action table are still basically the same; the exception is that the ship will not maneuver on range. The bearing taker must shoot the bearing to the range markers the instant that they are in line. This method is only as accurate as the experience and ability of the bearing taker.

# Determining Gyro Error by Trial and Error

## Franklin Technique

The Franklin technique is extremely useful just prior to getting a ship under way. The Franklin technique provides an alternative and **must** be used if the gyro error cannot be checked by another method prior to getting under way. To determine gyro error using the Franklin technique follow the steps in the table and refer to figure 2-22.

Step	Action
1.	Select three to five nav aids from the chart. For the best results, the selected nav aids should be about 120" apart. (The ship must be pierside or anchored, large towers and conspicuous buildings may be selected).
2.	Compare the repeater(s) to be used against the master gyro; note errors.
3.	Take a round of bearings on the selected nav aids, and apply any repeater error to the bearing.  <b>Example:</b> The repeater reads 187° and the master gyro reads 187.5°. The repeater is reading ½° less than (compass least error east). Since the error is 0.5° east (less than), 0.5 <b>must</b> be added to all bearings taken from that repeater.
4.	Plot the corrected bearings on the chart with the PMP set for 0° gyro error.
5.	Observe how the lines intersect, if they meet in a point the gyro is "ON" and has no error. If the lines do not intersect, subtract or add 1.0° at a time until the triangle closes. The amount of correction is the total gyro error. Log it in the deck log and Magnetic Compass Record Book.

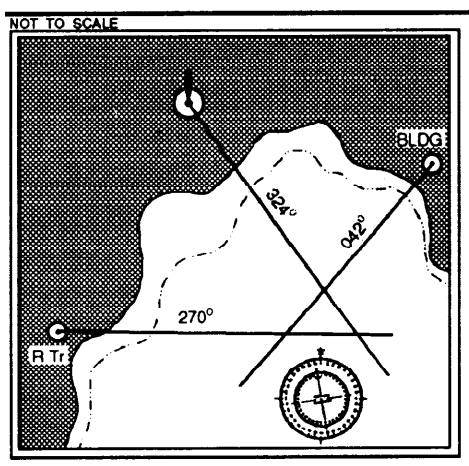

ACTUAL BEARINGS TAKEN

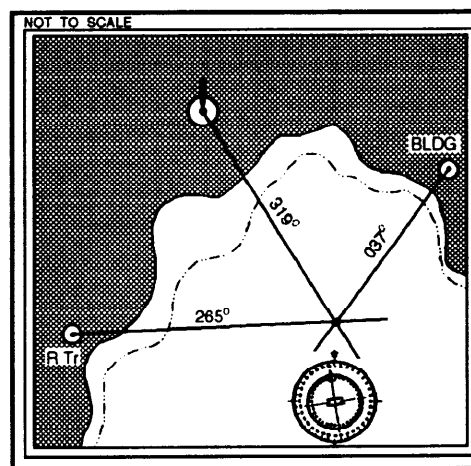

BEARINGS ADJUSTED BY SUBTRACTING 5 DEGREES (GYRO ERROR = 5° W)

Figure 2-22. Determining gyro error by adjusting bearings.





# CHAPTER 3

## Navigational Publications

---

### Introduction

In this chapter you learn of the various publications that are routinely used by the Quartermaster. The QM uses many types and forms of written documents to make possible the full and efficient execution of his or her duties. The majority of these documents are prepared by various governmental agencies, although some originate from commercial sources. The term *document* here is used in a broad sense to include charts, tables, books, and pamphlets, and devices that relate to navigation. We learned about charts in chapter 1 and the Light List in chapter 2. We will now familiarize you with navigational publications that you as a Quartermaster will use.

---

### Objectives

The material in this chapter will enable the student to:

- Select the use of and match publications from a list.
- 

Topic	Page
Navigational Publication Quick Reference Guide	3-2
Coast Pilots	3-4
Fleet Guides	3-4
Sailing Directions	3-5
List of Lights	3-6
Tide Tables and Tidal Current Tables	3-7
Pilot Charts	3-7
World Port Index	3-8
Distances Between Ports	3-8
Almanacs	3-9
Sight Reduction Tables	3-9
Publication Corrections and Ordering	3-10

# Publications

---

## Introduction

Government agencies conduct field surveys and research studies of their own. They collaborate with each other and with similar activities in many foreign nations to make sure their charts and other publications will contain the most recent and accurate information. A very valuable input to all types of navigational documents results from reports made by vessel's crews as to new and changed situations.

This chapter is divided into three areas:

- Transit Planning Publications
- Almanacs and Sight Reduction Tables
- Publication Correction and Ordering

The following table has been provided as a quick reference guide. It gives a description of many of the publications that Quartermasters use routinely. Many of these publications will be covered in greater detail in this chapter or elsewhere in this text.

## Navigational Publication Quick Reference Guide

Pub Number	Pub Name	Main Focus	Description	Published by/ Available from
	Tidal Current Tables	Prediction Tables	Provide tidal current data, worldwide coverage comprising four volumes.	NOS
	Tide Tables	Prediction Tables	Provide tidal and astronomical data, worldwide coverage comprising four volumes.	NOS
	Chart # 1	Aids to Navigation Systems	A complete listing of all aids to navigation and chart symbology.	NOAA and DMAHTC/ DMA S/N WOBZC1
	Pilot Charts	Planning	Available in atlas form for each ocean basin.	NOAA

## Publication Quick Reference Guide, Continued

<b>PubNumber</b>	<b>PubName</b>	<b>Main Focus</b>	<b>Description</b>	<b>Published by/ Available from</b>
<b>9</b>	American Practical Navigator	Technical Navigation Reference	A comprehensive technical reference covering all aspects of navigation. Includes two volumes.	DMAHTC/ DMA S/N NVPUB9V1  NVPUB9V2
<b>102</b>	International Code of Signals	Flag and Light Signals	Specific information on sending signals to non-NATO ships.	DMAHTC/ DMA S/N NVPUB 102
<b>117</b>	Radio Navigational Aids	Radio Signal Information Systems	A reference guide for NavTex, NavInfoNet, and GPS operation.	DMAHTC/ DMA S/N RAPUB117
<b>121 through 200</b>	Sailing Directions	Planning Information	Contains in-depth information on ports and seacoasts.  Broken down into volumes containing planning guides and en route guides.	DMAHTC\ Refer to DMA publication DMA Catalog of Maps, Charts, and Related Products, Part 2, Vol 1, Section 10
<b>150</b>	World Port Index	Port Information	Contains specific information on ports around the world in an easy to use table format.	DMAHTC/ DMA S/N NVPUB150
<b>229</b>	Sight Reduction Tables	Celestial Interpolation Tables	Covers 160 of latitude North or South; available in six volumes for all latitudes.	DMAHTC\ Refer to DMA publication DMA Catalog of Maps, Charts, and Related Products, Part 2, Vol 1, Section 10
<b>110-116</b>	List of Lights	Lights, Radio Aids, Fog Signals	Provides specific information on lights and light structure for all areas not covered by Light Lists.	DMAHTC\ Refer to DMA publication DMA Catalog of Maps, Charts, and Related Products, Part 2, Vol 1, Section 10

# Transit Planning Publications

---

## Introduction

Transit planning can best be described as the process of gathering and compiling information to ensure a safe and efficient voyage. There are many publications that the Quartermaster uses for transit planning. The publications listed in this section must be studied thoroughly. You should make every attempt to establish an in-depth working knowledge of all publications that are available to the QM.

---

## Coast Pilots

Charts are limited in what can be shown by symbols and abbreviations regarding channels, hazards, winds and currents, restricted areas, port facilities, pilotage service, and many other types of information needed by a navigator for safe and efficient navigation. These deficiencies are remedied by the *Coast Pilots* published by NOS and the *Sailing Directions* published by DMAHTC.

*U.S. Coast Pilots* are published in nine numbered volumes to cover the waters of the United States and its possessions. They are of great value to a navigator when used with charts of an area both during the planning stage of a voyage and in the actual transit of the area. The contents of *Coast Pilots* have been stored in a computerized data bank, and volumes are reprinted annually with all intervening changes included (except CP8 and CP9, which are revised every 2 years). Interim changes are published in *Notices to Mariners* and *Local Notices to Mariners*.

---

## Fleet Guides

The Defense Mapping Agency Hydrographic/Topographic Center publishes, for U.S. Navy use only, *Fleet Guides*. These are Pub. No 940, Atlantic Area, and Pub. No 941, Pacific Area. These guides contain a number of chapters, each of which covers a port of major interest to naval vessels. They are prepared to provide important command, navigational, repair, and logistic information. This information is much like that contained in *Coast Pilots* and *Sailing Directions*, but it is oriented toward naval interests and requirements; they are not needed by, nor are they available to, non-naval vessels.

The information in *Fleet Guides* is corrected and updated through the publication of changes and/or new editions when required; interim corrections are published in *Notices to Mariners* if the urgency so warrants.

# Transit Planning Publications, Continued

## Sailing Directions

The DMAHTC *Sailing Directions* provide information comparable to the *Coast Pilots* for foreign coasts and coastal waters. They also provide detailed information for the navigation team that cannot be shown on charts. The appropriate volume of *Sailing Directions*, used with charts of a suitable scale, should enable a navigator to approach strange waters with adequate information for the vessel's safety.

The *Sailing Directions* are based on a division of the world's water into eight "ocean basins" (but these are not the same as those used for two- and three-digit chart numbers). *Sailing Directions* are given three-digit identification numbers starting with DMAHTC Pub No. 121. The *Sailing Directions* are made up of two components and contain information as follows:

Planning Guides. Each *Planning Guide* covers an ocean basin containing chapters of useful information about countries adjacent to that particular ocean basin; information relative to the physical environment and local coastal phenomena; references to publications and periodicals listing danger areas; recommended ship routes; detailed electronic navigation systems and buoyage systems pertaining to that ocean basin.

Changes for each *Planning Guide* and *En route* volume are prepared and published on an as-required basis determined by the number of accumulated revisions.

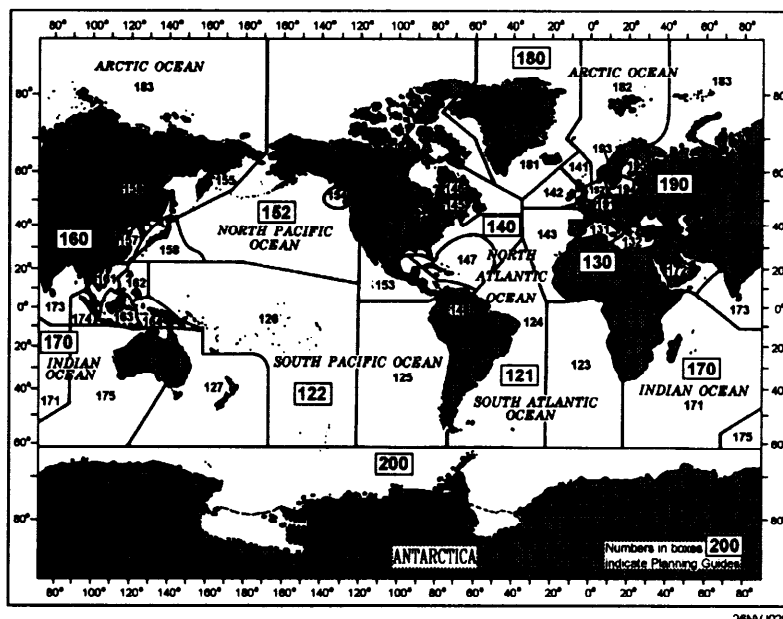

Figure 3-1. Limits of Sailing Directions.

## Transit Planning Publications, Continued

### Sailing Directions; En-Route Volumes

En Route Volumes. Each *En route* volume includes detailed coastal and port approach information, supplementing the largest scale chart available from DMAHTC. It is intended for use in conjunction with the *Planning Guide* for the ocean basin concerned. Each *En route* volume is divided into a number of sectors, and for each sector information is provided on available charts (with limits shown on an overall diagram as in U.S. chart catalogs); winds, tides, and currents (shown on an outline chart); off-lying dangers; coastal features; anchorages; and major ports (an annotated chartlet with line drawings of aids to navigation and prominent landmarks). Figure 3-1 shows the limits for all *Sailing Directions* volumes.

### List of Lights

The DMAHTC *List of Lights*, seven volumes, cover foreign coasts of the world (and limited portions of U.S. coasts); these are Pubs. No. 110 through 116 (see fig. 3-2). The *List of Lights* volumes include descriptive information similar to *Lights Lists*, but because of their greater coverage areas, they list only lighted aids to navigation and fog signals (lighted buoys within harbors are omitted). Each *List of Lights* is published in a new edition at intervals of approximately 12 months; changes and corrections are included frequently, as they are required, in *Notices to Mariners*.

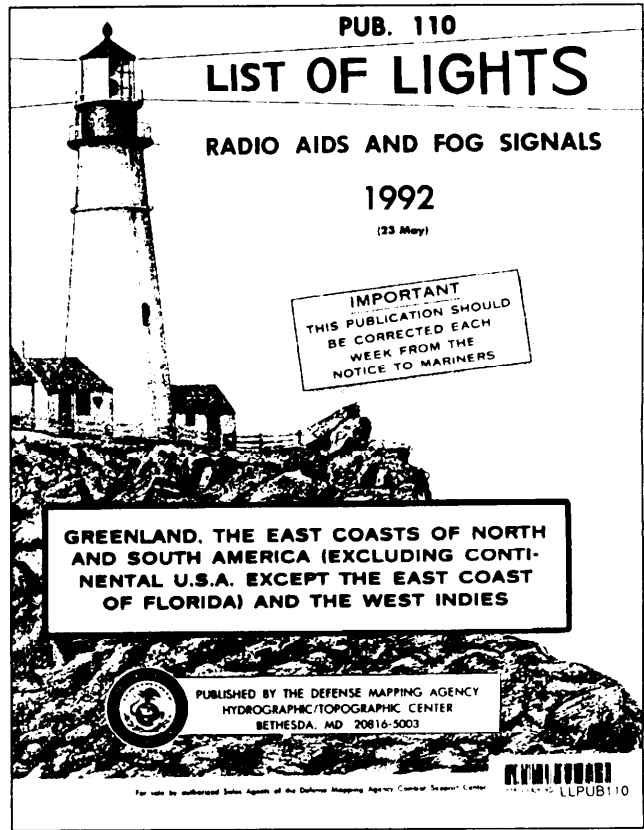

Figure 3-2. List of Lights.

## Transit Planning Publications, Continued

---

### **Tide Tables and Tidal Current Tables**

The *Tide Tables* are prediction tables published in four volumes by the National Ocean Service. They are *East Coast of North and South America, including Greenland*; *West Coast of North and South America, including the Hawaiian Islands*; *Europe and the West Coast of Africa, including the Mediterranean Sea*; and *Central and Western Pacific Ocean and the Indian Ocean* (annual editions). Each volume includes information on the height and time of high and low water at thousands of locations; also included is information on times of sunrise and sunset, moonrise and moonset, and other astronomical phenomena. The *Tide Tables* will be covered in detail in chapter 7.

*Tidal Current Tables* are prediction tables published in two volumes by NOS--*Atlantic Coast of North America*, and *Pacific Coast of North America and Asia* (annual editions); each volume includes data on the times and strengths of flood and ebb currents and the time of slack water for thousands of locations; also included are diagrams for certain heavily traveled bodies of water that facilitate determination of optimum transit times and speeds, and astronomical data similar to that in *Tide Tables*. The *Tidal Current Tables* will be covered in detail in chapter 7.

---

### **Pilot Charts**

The *Pilot Charts* present available data in graphic form that will assist the mariner in selecting the safest and fastest routes. Besides timely information of a varied nature, *Pilot Charts* graphically depict magnetic variation, currents, prevailing winds and calms, percentage of gales, tracks of tropical and extratropical cyclones, wave heights, surface air and water temperatures, percentage of fog, surface barometric pressure, ice and iceberg limits, the location of ocean weather-station ships, and recommended routes for steam and sailing vessels. Additionally, such topics as winds (including gales and cyclones), pressures, temperatures, visibility, and wave heights are discussed in brief paragraphs at the sides of each chart. *Pilot Charts* are published quarterly with each sheet containing three monthly charts and an article of general information.

## Transit Planning Publications, Continued

### Distances Between Ports

*The Distances Between Ports* publication contains information on ports of entry for the world. It is useful and easy to use. Ports are indexed by number and name and laid out in a tabular format. The World Port Index should be used as a quick reference guide only. Up-to-date information and specific planning information must be obtained from the applicable *Sailing Directions*, *Coast Pilot*, or *Fleet Guide*.

Another useful publication that gives information concerning the distance a ship must travel between *two* ports is *Distances Between United States Ports*, published by NOS; it tabulates approximately 10,000 distances along the shortest routes marked by aids to navigation.

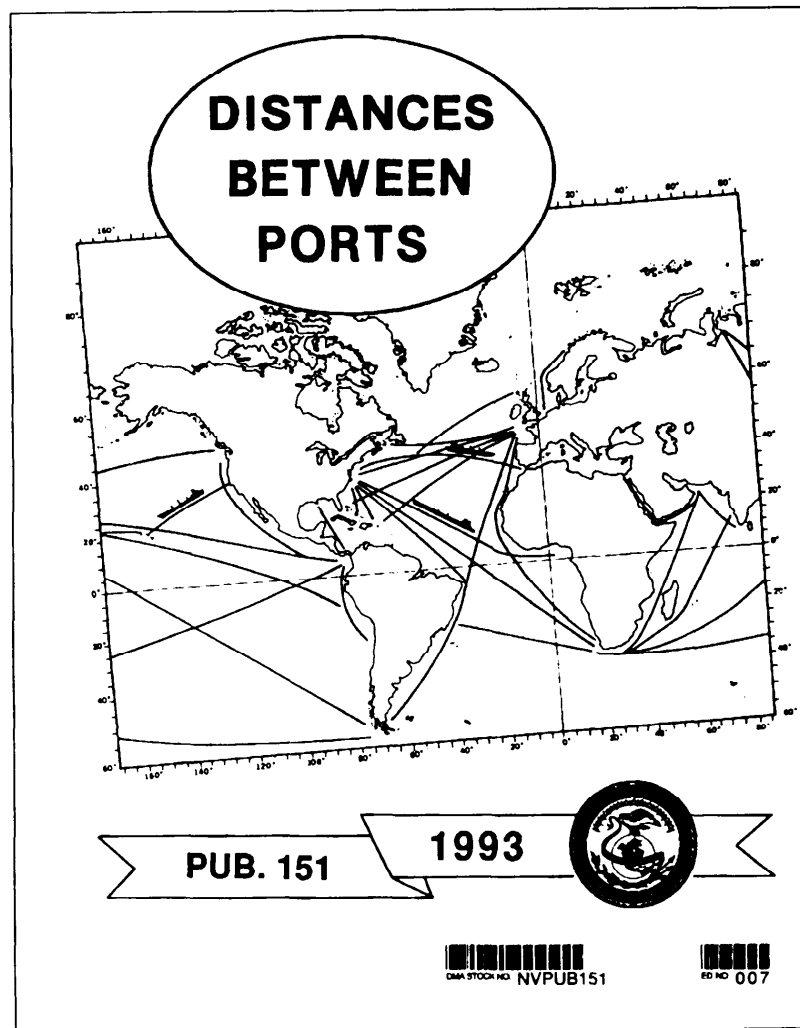

26NVJ031

Figure 3-3. Distances Between Ports.



# Celestial Navigation Publications

---

## Almanacs

*Nautical Almanacs*, volumes of information that tabulate the position of various celestial bodies, the times of sunrise and sunset, moonrise and moonset, and other astronomical data used by navigators, are prepared jointly by the U.S. Naval Observatory and the Royal Greenwich Observatory in England. However, the almanac volumes are printed both in the United States and in England.

The *Nautical Almanac* is published annually, and the *Air Almanac* is published twice each year. These publications give ephemeristic data for marine and air navigation respectively (the *Air Almanac* can be, and sometimes is, used by marine surface navigators). These volumes are used in many other countries with minor modifications, chiefly changes in the language used for page headings and in the explanatory material. *The Almanac for Computers* is also published by the U.S. Naval Observatory with mathematical data and instructions for the computation of ephemeristic data using electronic computers or advanced models of calculators. These almanacs are discussed in greater detail in later text.

---

## Tables

*Sight Reduction Tables for Marine Navigation*, Pub. No. 229, published by DMAHTC, in six volumes, each volume covering 16° of latitude, North or South (1° overlap between volumes) (see chapter 9).

*Sight Reduction Tables for Air Navigation*, Pub. No. 249, published by DMAHTC in three volumes; offers somewhat greater ease and speed in sight reduction, but has a limited range of declination and gives a lower order of precision as to position (see chapter 9).

# Publication Correction and Ordering

---

## Introduction

As charts and other publications accumulate a sufficient number of changes and corrections, they are reprinted as a revision with the same edition number or as a new edition. Certain publications, such as *Light Lists* and *Coast Pilots*, are reprinted on an annual schedule. Other publications may have numbered "changes" issued, usually in the form of reprinted pages for direct insertion into the volume after the superseded pages are removed.

---

## Publication Correction

Publication correction procedures are the same as those listed in chapter 1 for charts using the *Notices to Mariners* each week. The exception is that you will either make direct pen and ink changes to the text in publications or you may cut and paste information into the affected publication.

**Caution:** Do NOT use tape to make changes to publications, when cutting and pasting information, use a glue stick to paste information.

---

## Ordering

Most publications are available from DMAHTC. Refer to chapter 10 of *the DMA Catalog of Maps, Charts, and Related Products* to obtain the correct DMA stock number. Follow the same procedures as you would to order a chart as listed in chapter 1.

# Chapter 4

## The Nautical Road

---

### Introduction

In this chapter, you will be introduced to the components of the maritime highway. Just as you would travel along a roadway in your car by referring to a map and the road signs, the high seas, coastal approaches, and harbors all have unique signposts to help ships find their way.

The Nautical Road is comprised of two separate areas; Aids to Navigation (ATONs) and the Navigation Rules. The ATONs are like the signposts on the highway and the Navigation Rules compare to the traffic laws that we follow.

---

### Objectives

Completion of this material will enable the student to:

- Identify buoyage systems.
- Recognize buoy types and state their purpose.
- Compute the visibility of navigational lights.
- Recognize day and range markers and state their purpose.
- State the purpose of the rules of the road.
- Describe all steering and sailing rules.
- List at least four elements that make up an ATON's characteristics.
- Identify the following characteristics of ATON:
  - a. Color
  - b. Light rhythm and cycle
  - c. Number
- State the two factors that determine the visibility of a lighted ATON.
- Identify the following terms associated with light visibility computations:
  - a. Horizon distance
  - b. Meteorological visibility
  - c. Luminous range
  - d. Nominal range
  - e. Geographic range
  - f. Computed range
  - g. Computed visibility

## Objectives, Continued

### Objectives

- List the three elements used to identify a light at night.
- State the differences between primary and secondary lights.
- List two purposes of ranges.
- Identify the differences between directional lights, daybeacons, and minor lights.
- Describe how light sector bearings are plotted on charts.
- State the reason why sound signals are used on ATONs.
- State the purpose of a RACON.
- Identify the function of a buoyage system.
- List the characteristics of lateral and cardinal buoyage systems.
- Identify the differences between IALA region A and IALA region B.
- State which IALA region applies to the United States.
- Identify and explain variations in the following U.S. Systems of ATONs:
  - a. Intracoastal waterway (ICW)
  - b. Western rivers
  - c. Uniform State Waterway Marking System (USWMS)
- Identify and distinguish between international and inland rules of the road.

Topic	Page
Navigational Lights	4-3
How to use the Light List	4-5
Characteristics of Lighted Aids to Navigation	4-6
Visibility of Lights	4-8
Types of Lights and Structures	4-14
Sector Lights	4-21
Buoys	4-24
Buoyage Systems	4-28
The United States System of Aids to Navigation	4-30
Rules of the Road	4-39
Maneuvering and Warning Signals	4-44

# Navigational Lights

---

## Information

A ship cannot suspend operations merely because darkness falls and daytime aids cannot be distinguished. For that reason, aids to navigation are lighted whenever it is necessary and practical. For purposes of identification, lights have **individual characteristics** regarding *color, brilliancy, and system of operation.*

A light's characteristics are usually printed on the chart near its symbol. Detailed information on any particular aid to navigation may be found in the appropriate volume of the *Light List*.

As you learned in the previous chapter, the Defense Mapping Agency Hydrographic/ Topographic Center (DMAHTC) publishes *List of Lights* in seven volumes which cover aids to navigation outside the continental United States.

Aids located in the United States and its possessions are described in *Light List* volumes published by the U.S. Coast Guard.

---

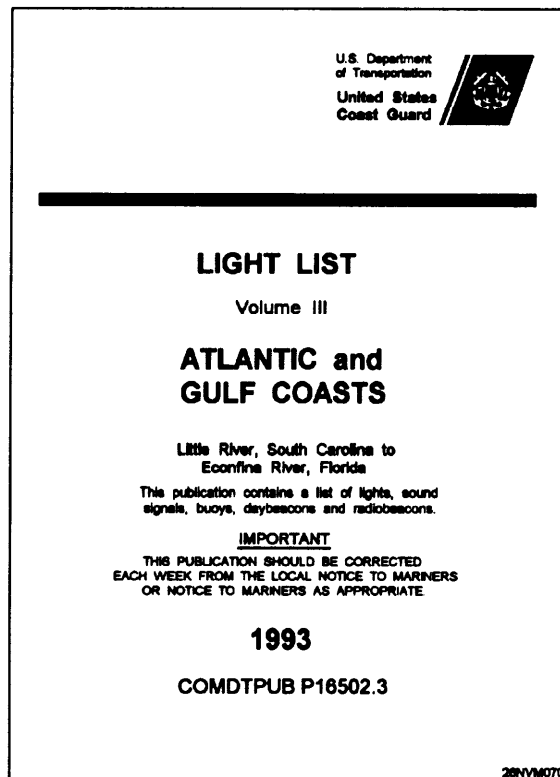

Figure 4-1. Light List.

# Light List

## Introduction

Since the *Light List* is such an important publication for the Quartermaster, and because you will no doubt use it frequently, we will review it in greater detail here.

*Light List* for the United States and its possessions, including the Intracoastal Waterway, the western rivers, and the Great Lakes for both the United States and Canadian waters, are published annually by the U.S. Coast Guard in six volumes.

## Composition

Each volume provides information on ATONs within a specific area of the country; for example, Volume I, Atlantic Coast, describes aids to navigation from St. Croix River, Maine, to Toms River, New Jersey. Volume VI, Pacific Coast and Pacific Islands describes aids to navigation on the Pacific Coast and outlying islands and so on.

The aids are listed such that seacoast aids appear first, followed by entrance and harbor aids from seaward to the head of navigation. Light List Numbers (LLNR) are assigned to all ATONs to facilitate reference in the *Light List* and to resolve ambiguity when referencing ATONs. Table 4-1 explains the page layout of the *Light List*.

Table 4-1. Sample of *Light List*

(1) No.	(2) Name and location	(3) Position	(4) Characteristic	(5) Height	(6) Range	(7) Structure	(8) Remarks
GEORGIA- Seventh District							
	<b>Whitehall Channel</b>						
4445	SAVANNAH BULK TERMINAL SOUTH LIGHT	32 08.0 81 08.5	F G	24		On pier	Private Aid
4450	SAVANNAH BULK TERMINAL NORTH LIGHT		F G	24		On pier	Private Aid
Column (1)	Column (2)	Column (3)	Column (4)	Col (5)	Col (6)	Column (7)	Column (8)
Light List Number	Name of the aid to navigation	Geographic position in latitude and longitude	Light characteristic for a lighted aid to navigation.  Morse code for a radiobeacon	Height of light above mean high water	Nominal Range	See Below	See Below

Column (7) Structural characteristic of the aid to navigation, including dayboard (if any), description of fixed structure, color and type of buoy, and height of the structure above ground.

Column (8) General remarks, including fog signal characteristic, RACON characteristics, lights sector's arc of visibility, radar reflector if installed, emergency lights, seasonal remarks, and private aid identification.

# How to Use the Light List

## Example

Using the *Light List* is simple. As an example, suppose you need to know the position and characteristic of Key West Harbor Range. To find this information in the *Light List* follow these three steps while referring to table 4-2.

Step	Action
1.	Look up the LLNR for Key West Harbor Range in the index.
2.	Next, find the page listing LLNR 12990 in the main pages. Each aid to navigation is listed numerically by LLNR.
3.	Extract the information you need for the aid. In this case, the position of the light is 24°34.7'N, 081°48.0'W; characteristic is quick flashing white.

Key West Harbor Main Channel .....	12890
KEY WEST HARBOR RANGE ..... LLNR ☞	12990

Table 4-2. Excerpt from *Light List*, Volume III, 1993

(1) No.	(2) Name and location	(3) Position	(4) Characteristic	(5) Height	(6) Range	(7) Structure	(8) Remarks
<b>KEY WEST HARBOR AND APPROACHES</b>							
<b>Key West Harbor Main Channel</b>							
12985	- Lighted Buoy 15		Fl G 4'		4	Green	
12990	KEY WEST HARBOR RANGE FRONT LIGHT	24 34.7 81 48.0	Q W	16		KRW on Dolphin	Visible all around

# Characteristics of Lighted Aids to Navigation

## Introduction

Lights displayed from ATONs have distinct characteristics (rhythms) which help you identify them. They all exhibit a distinctive flashing rhythm. Use figure 4-2 to find the characteristic for any light.

Illustration	Type Description	Abbreviation
	1. <b>FIXED.</b> A light is showing continuously and steadily.	F
	2. <b>OCCULTING.</b> A light which the total duration of light in a period is longer than the total duration of darkness and the intervals of darkness (eclipses) are usually of equal duration.	
	2.1 <b>Single - occulting.</b> An occulting light in which an eclipse is regularly repeated.	Oc
	2.2 <b>Group - occulting.</b> An occulting light in which a group of eclipses, specified in numbers, is regularly repeated.	Oc(2)
	2.3 <b>Composite group - occulting.</b> A light, similar to a group - occulting light, except that successive groups in a period have different numbers of eclipses.	Oc(2+1)
	3. <b>ISOPHASE.</b> A light in which all durations of light and darkness are equal.	Iso
	4. <b>FLASHING.</b> A light in which the total duration of light in a period is shorter than the total duration of darkness and the appearances of light (flashes) are usually of equal duration.	
	4.1 <b>Single - flashing.</b> A flashing light in which a flash is regularly repeated (frequency not exceeding 30 flashes per minute).	Fl
	4.2 <b>Group - flashing.</b> A flashing light in which a group of flashes, specified in number, is regularly repeated.	Fl(2)
	4.3 <b>Composite group - flashing.</b> A light similar to a group (flashing light except that successive groups in the period have different numbers of flashes.	Fl(2+1)
	5. <b>QUICK.</b> A light in which flashes are produced at a rate of 60 flashes per minute.	Q
	5.1 <b>Continuous quick.</b> A quick light in which a flash is regularly repeated.	
	5.2 <b>Interrupted quick.</b> A quick light in which the sequence of flashes is interrupted by regularly repeated eclipses of constant and long duration.	IQ
	6. <b>MORSE CODE.</b> A light in which appearances of light of two clearly different durations (dots and dashes) are grouped to represent a character or characters in the Morse code.	Mo(A)
	7. <b>FIXED AND FLASHING.</b> A light in which a fixed light is combined with a flashing light of higher luminous intensity.	FFI
	8. <b>ALTERNATING.</b> A light showing different colors alternately.	Al RW

26NVM071

Figure 4-2. Light characteristics.



# Characteristics of Lighted Aids to Navigation, Continued

---

## Defined

Some aids, such as safe-water marks always use the same rhythm (Morse "A"), while others may display one of several different rhythms. Figure 4-2 on the previous page gives a description and definition of light characteristics (rhythms) as well as their chart symbol abbreviations. Abbreviations are used on charts because of space restrictions.

When working with composite light abbreviations, you must carefully distinguish between the meanings of the numbers in parentheses following a composite-flashing light. In the case of the composite-flashing light, the numbers refer to the pattern of the flashes of light. On the contrary, when the light is a composite-occluding light, the numbers within the parentheses denote the pattern of the eclipses in the light.

---

## Light Cycle

The "Light Cycle," or period of a light, is the time it takes a light to complete one full cycle of ON and OFF changes. By varying the length of the cycles, a clear distinction can be made between numerous aids in the same area.

---

## Numbering and Lettering

All solid red and solid green ATONs are numbered. Red aids have even numbers; green aids have odd numbers. The numbers for each increase from seaward, proceeding in the conventional direction of buoyage. Numbers are kept in approximate sequence on both sides of the channel by omitting numbers where necessary.

Letters may be used to augment numbers when lateral aids are added to channels with previously completed numbering sequences. If letters are used, they will increase in alphabetical order from seaward and will be added to numbers as suffixes.

No other aids are numbered. Preferred-channel, safe-water, isolated danger, special marks, and information or regulatory aids may be lettered, but not numbered.

# Visibility of Lights

## Information

The visibility of a lighted ATON depends upon two factors: **the light's intensity** and the **light's height above water**. There will be times when you will want to know the specific distance at which you will be able to see a light, such as approaching land from sea. This information can be helpful in determining the ship's position.

**Rule:** When a ship is under way all navigational lights that will be sighted during periods of darkness must be identified in the Captain's Night Orders. It is desirable to also define the time at which the light should be sighted.

## Process

Refer to the following table to view the process of determining the visibility of a light.

Step	Action	Result
1.	Locate the light on the chart and note the name of the light.	Information gained for obtaining LLNR from the Light List.
2.	Extract the characteristics from the Light List.	Height of eye computation can now be done.
3.	Compute the distance at which the light should be sighted from the height of eye table.	Information concerning when a light should be sighted is obtained.

Table 4-3. Height of Eye

Height			Height			Height		
Feet	Meters	Distance Nautical Miles	Feet	Meters	Distance Nautical Miles	Feet	Meters	Distance Nautical Miles
5	1.5	2.6	70	21.3	9.8	250	76.2	18.5
10	3.1	3.7	75	22.9	10.1	300	91.4	20.3
15	4.6	4.5	80	24.4	10.5	450	106.7	21.9
20	6.1	5.2	85	25.9	10.8	400	121.9	23.4
25	7.6	5.9	90	27.4	11.1	450	137.2	24.8
30	9.1	6.4	95	29.0	11.4	500	152.4	26.2
35	10.7	6.9	100	30.5	11.7	550	167.6	27.4
40	12.2	7.4	110	33.5	12.3	600	182.9	28.7
45	13.7	7.8	120	36.6	12.8	650	198.1	29.8
50	15.2	8.3	130	39.6	13.3	700	213.4	31.0
55	16.8	8.7	140	42.7	13.8	800	243.8	33.1
60	18.3	9.1	150	45.7	14.3	900	274.3	35.1
65	19.8	9.4	200	61.0	16.5	1000	304.8	37.0

## Visibility of Lights, Continued

### Understanding the Relationships Among Terms

There are several terms associated with any light's visibility. Figure 4-3 will help you to visualize the relationships existing among these terms as they apply in a situation in which an observer with a height of 50 feet is located exactly at the computed range to a light having a geographic range of 11.7 miles and a nominal range of 15 miles. Review figure 4-3 and the associated terms list on the next page.

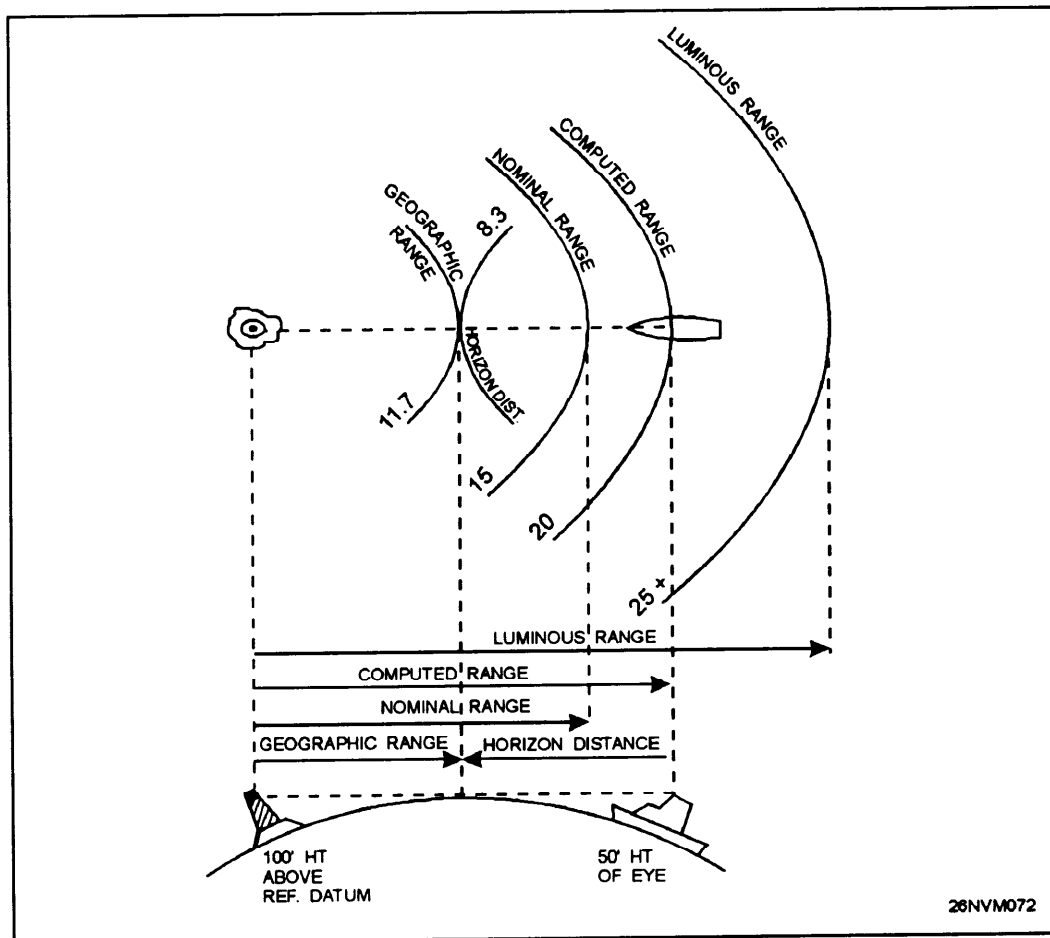

Figure 4-3. Relationship of light visibility terms.

## Visibility of Lights, Continued

---

### Terms

The following is a list of terms associated with light visibility computations:

**Horizon distance** - This is the distance expressed in nautical miles from the position above the surface of Earth along a line of sight to the horizon; the line along which Earth and sky appear to meet. The higher the position, the farther the horizon distance will be. Figure 4-3 shows the relationship of height of eye to horizon distance.

**Meteorological visibility** - Meteorological visibility results primarily from the amount of particulate matter and water vapor present in the atmosphere at the location of an observer. It denotes the range at which the unaided human eye can see an unlighted object by day in a given set of meteorological conditions.

**Luminous range** - Luminous range is the maximum distance at which a light may be seen under the existing meteorological visibility conditions. Luminous range does not take into account the height of the light, the observer's height of eye, or the curvature of Earth. It depends only on the intensity of the light itself.

**Nominal range** - Nominal range is the maximum distance a light can be seen in **clear** weather (meteorological visibility of 10 nautical miles). Nominal range is similar to luminous range in that it does not take into account elevation, height of eye, or curvature of Earth, but it depends on the intensity of the light. Nominal range is listed in column 6 of the *Light List* for all lighted aids to navigation except range lights, directional lights, and private aids to navigation.

**Geographic range** - Geographic range is the maximum distance at which a light may be seen in perfect visibility by an observer whose eye is at sea level.

**Computed range** - Computed range is the geographic range plus the observer's distance to the horizon based on the observer's height of eye.

**Computed visibility** - Computed visibility is the visibility determined for a light using the light's height, nominal range, and height of eye of the observer.

# How to Compute the Visibility of a Light

**Information**

Frequently, the navigator will want to know at what time and position on the ship's track a given light might be sighted. This information is especially important when the ship is making a landfall. Failure to sight certain lights when expected could mean that a navigational error has been made. The distance calculated is termed the *computed visibility* of the light.

**Rule:** When you compute the visibility of a light, the computed visibility will **NEVER** exceed the light's luminous range.

**Examples**

The following examples illustrate the recommended procedure for determining the visibility of a light. Bear in mind that computed visibility cannot be greater than the luminous range.

**Example 1:** Determine the visibility of light Alpha for an observer with a height of eye of 50 feet.

**Solution:** From the *Light List*, the nominal range is determined to be 20 miles; the height of light Alpha is 90 feet above the water. Determine horizon distance from table 4-1.

Height of eye for 50 feet	8.3 miles
Height of light (80 feet)	<u>11.1 miles</u>
Computed visibility	19.4 miles
Nominal range	20.0 miles
Answer:	19.4 miles

**Example 2:** Determine the visibility of light Bravo for an observer with a height of eye of 35 feet.

**Solution:** From the *Light List*, determine the nominal range (10 miles) and the height of the light above water (80 feet). Determine horizon distance from table 4-1.

Height of eye for 35 feet	6.9 miles
Height of light (80 feet)	<u>10.5 miles</u>
Computed visibility	17.4 miles
Nominal range	10.0 miles
Answer:	10.0 miles

# Luminous Range Diagram

## Luminous Range Diagram

The luminous range diagram (fig. 4-4) enables the mariner to determine the approximate range at which a light may be sighted at night in the existing meteorological visibility at the time of observation.

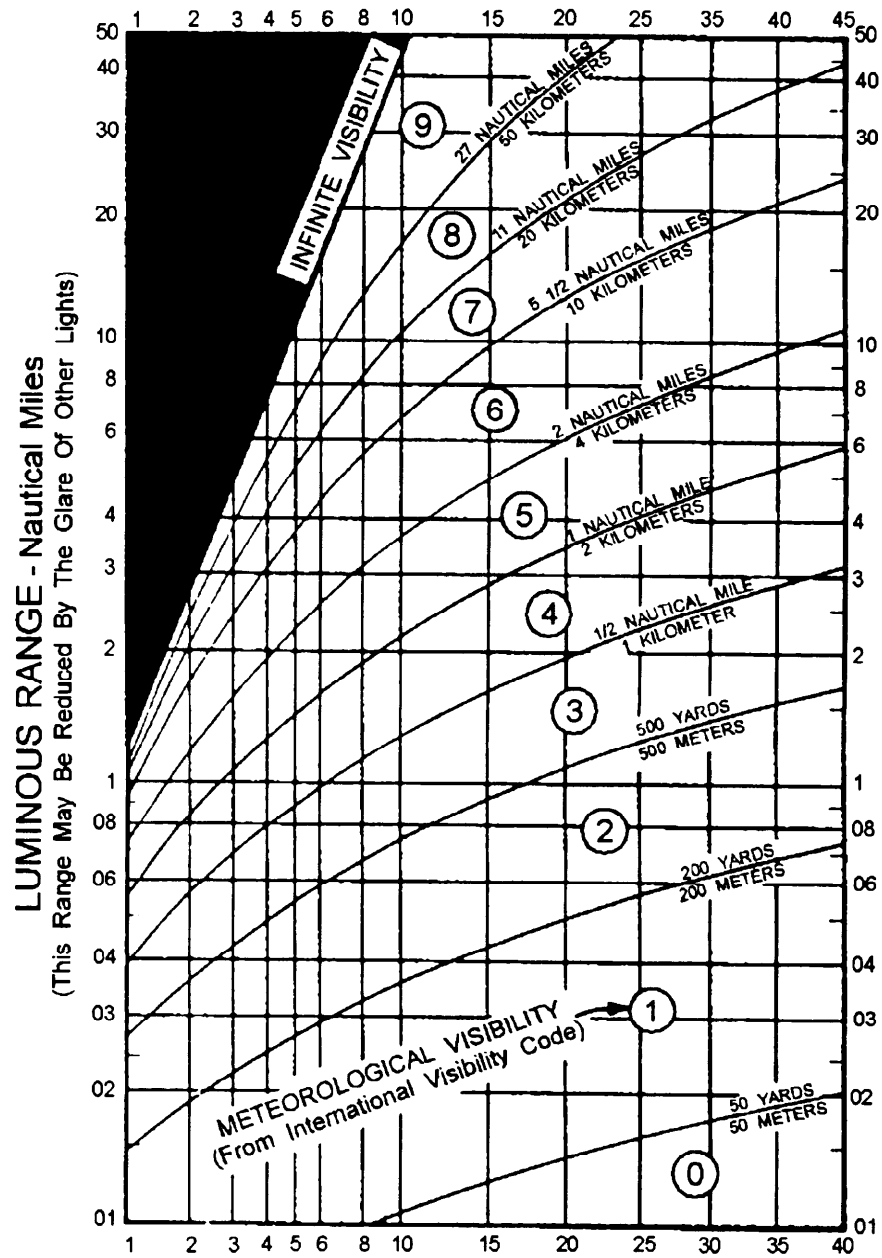

Figure 4-4. Luminous range diagram.

# How to Use the Luminous Range Diagram

---

## How to Use the Luminous Range Diagram

The diagram is entered from the top or bottom border, using nominal range obtained from *the Light List*. The figures along the curves represent the estimated meteorological visibility at the time of observation, and those along the left-hand border represent the luminous range under those conditions.

**Example:** A light has a nominal range of 20 miles. If the meteorological visibility is 20 miles, the light would be sighted at about 33 miles. If the meteorological visibility is only 5 miles, the luminous range of the light is about 12 miles.

When using this diagram, you must remembered that:

- the range obtained is approximate.
- atmospheric conditions may not be consistent between the observer and the light.
- the glare of background lighting will reduce the range at which light is sighted.

# Types of Lights and Light Structures

---

## Information

Primary and secondary lights are so designated because of their importance as ATONs. Primary seacoast aids are distinctive lights in the U.S. system of ATONs. They are "fixed" as opposed to "floating" and are maintained on the mainland, or on offshore islands and shoals to warn mariners of the nearness of land or dangers. They are usually the first ATONs that the navigator sees when making a landfall. The navigator can use these lights to keep farther offshore at night. When lights are located offshore, they mark a specific hazard or serve as a marker for ships approaching a major harbor.

Many lights are classified as primary lights because of the importance of their location, their intensity, and the prominence of their structures. Other aids are classed as secondary or minor lights because of their lesser qualities in one or more of these characteristics. The dividing line is not clear cut, and the difference is of no significance when applied to piloting situations.

---

## Lighthouses

These familiar structures are typical primary lights found along the coastlines around much of the world. Lighthouses are placed on prominent headlands and other points such as harbor entrances and isolated dangers to warn mariners of danger or to guide them. The principal purpose of the structure is to support a light source and lens at a considerable height above the water. The same structure may also house a fog signal, a radiobeacon, RACON, and other equipment.

Lighthouses vary greatly in shape and construction (fig. 4-5), which is determined in part by their location (whether in the water or on shore), the importance of their light, the kind of soil on which they are constructed, and the prevalence of violent storms. Since lighthouses are nonlateral aids, their paint schemes are quite different than traditional lateral marks. Lighthouse structures are painted in various patterns such as stripes and solids, which help mariners to easily distinguish them from other such structures in the same vicinity.



## Types of Lights and Light Structures, Continued

---

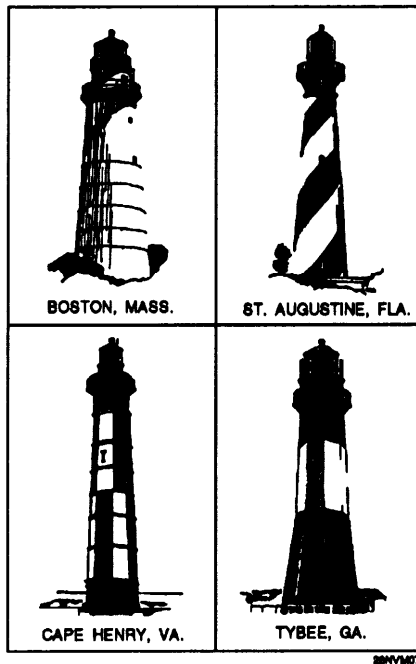

Figure 4-5. Typical lighthouses.

---

### Light Towers

For many years, lightships were used to mark offshore dangers or mark the entrances to important harbors. Today, however, lightships are no longer used in the United States. Instead, they have all been replaced by light towers or large navigational buoys (LNBS) which, especially in the case of the LNB, are much more economical to maintain.

A typical tower deckhouse is 60 feet above the water, 80 feet square, and supported by steel legs in pilings driven nearly 300 feet into the ocean bottom. Though once manned, these light towers are now automated. The light tower has a helicopter landing deck and houses equipment such as a radiobeacon, RACON, fog signal, and communications equipment. On one corner of the deckhouse is a radio tower supporting the radiobeacon antenna and a powerful light. At an elevation of 125 feet above the water, the light is visible for over 20 miles. Although construction details of other towers vary slightly, they are of the same general type.

## Types of Lights and Light Structures, Continued

### Ranges

One purpose of a range is to assist mariners in keeping their vessels on the centerline of a channel. The range may be lighted or unlighted and consists of two lights and daymarks located some distance apart with the front display lower than the rear. When the range markers appear one over the other as shown in figure 4-6, the vessel will remain within the limits of the channel. Another purpose of a range is to determine a ship's gyro error.

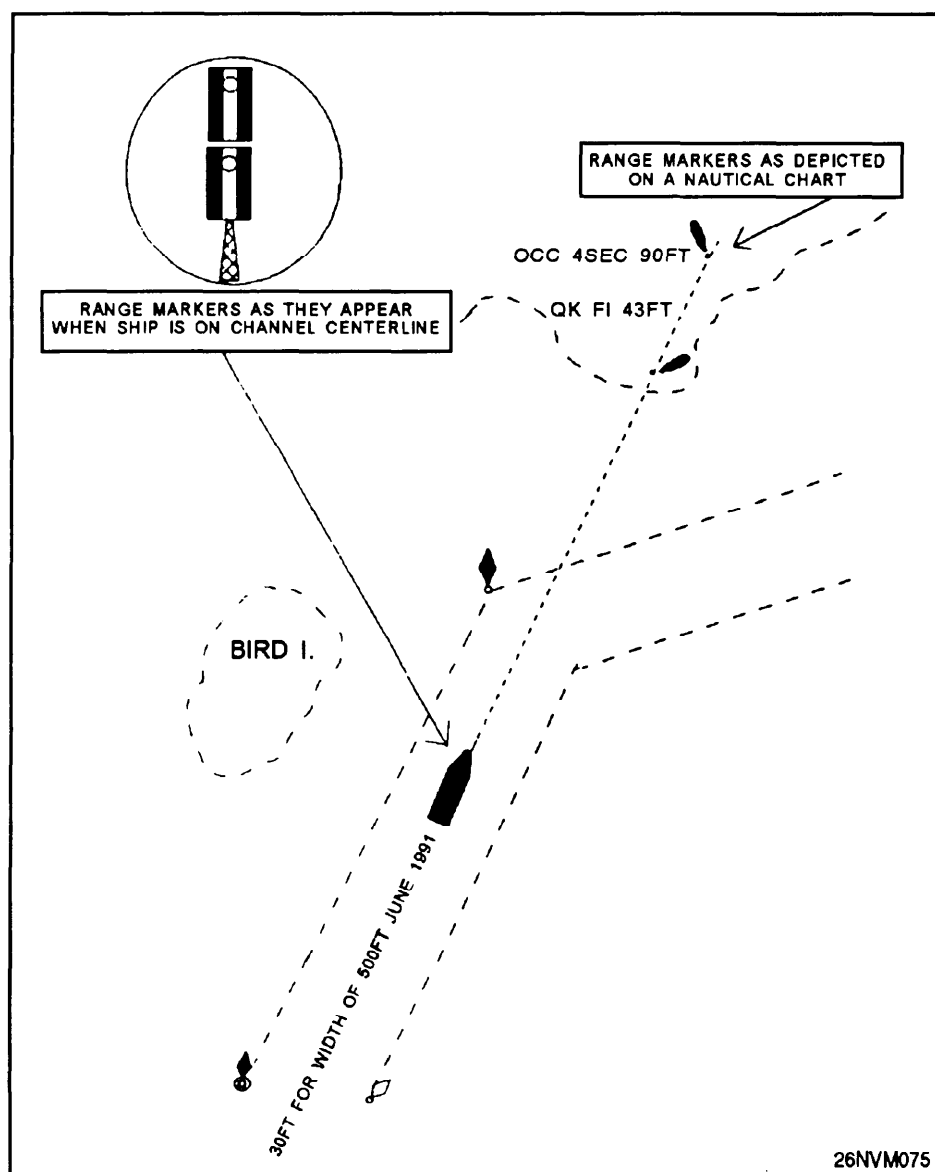

Figure 4-6. Using range markers.

# Types of Lights and Light Structures, Continued

## Ranges continued

For a given range, the true bearing of the range axis will be listed in column 2 of the *Light List* immediately below the name of the rear range. As you approach this range and line up the lights and daymarks as shown in figure 4-6, you are on channel centerline. In figure 4-6, if the channel axis is listed as 020° and your ship has the markers in line, your gyro compass should read 020°. If it does not, the difference in degrees will equal your gyro error.

While the range markers discussed above are precisely positioned to mark a channel, you should also be aware that natural ranges are also used on occasion. For example, a tank and a radio antenna, when observed in line, may form a natural range marking safe water.

## Directional Lights

In certain situations where range lights are desirable but not practicable to build, a less effective, but generally accepted substitute known as a directional light is used. A directional light illuminates a sector or displays a very narrow angle light beam for a ship to follow. In some cases, three colors of light are used. A high intensity white light will be bordered on each side with a green and red light. The green sector will mark the side of the channel with green buoys, and the red sector marks the side with red buoys. Remaining in the white sector keeps you in the channel.

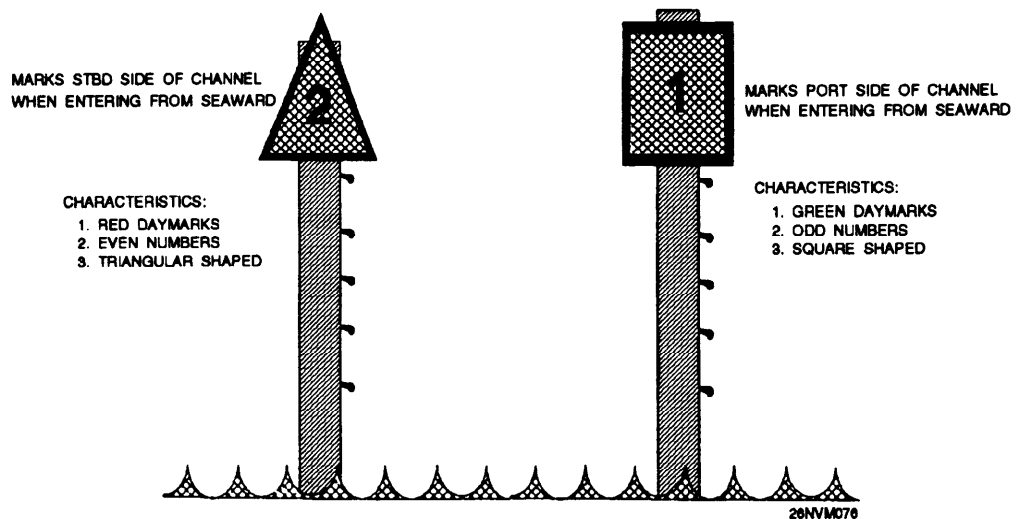

Figure 4-7. Daymarks.

## Types of Lights and Light Structures, Continued

---

### Daybeacons

There are many ATONs that are not lighted, especially in the inland waters of the United States. Structures of this are called daybeacons (fig. 4-7). They are not buoys, but are permanently mounted in position. Daybeacons vary greatly in design and construction, depending on their location and the distance from which they must be seen. A daybeacon may consist of a single pile with a daymark on the top, a multi-pile structure, a tower, or a structure of masonry or steel. Daybeacons are fitted with reflecting tape to facilitate their identification by searchlight at night. Daymarks marking the sides of channels are colored and numbered in the same manner as buoys, with red even-numbered marks indicating a starboard-side channel boundary and green odd-numbered marks on the portside channel boundary. The shapes for channel, preferred-channel, nonlateral, and safe-water daymarks, together with their chart symbols, are shown in chart No. 1 and on plate 1.

---

### Minor Lights

Just as daybeacons are sometimes substituted for unlighted buoys, lighted buoys are often replaced by minor lights (fig. 4-8). Minor lights are fixed structures of the same overall physical features as daybeacons, but are equipped with lights generally similar in characteristics to those found on buoys. Minor lights can be used in a series with other aids to mark channels, rivers, or harbors and can be used to mark some isolated areas.

The term *minor light* does not include the more important lights marking harbors, peninsulas, major shoals, and so on, which have lights of greater intensity and/or special characteristics and were discussed earlier in this manual. Daymarks are placed on the structures for identification, and reflective material is added for nighttime safety in case the light is extinguished. A minor light normally has the same color, flash, and phase characteristic as that of a lighted buoy. Intensity of the light is generally of the same order as that of a lighted buoy, but visibility may be increased by its greater height above water.

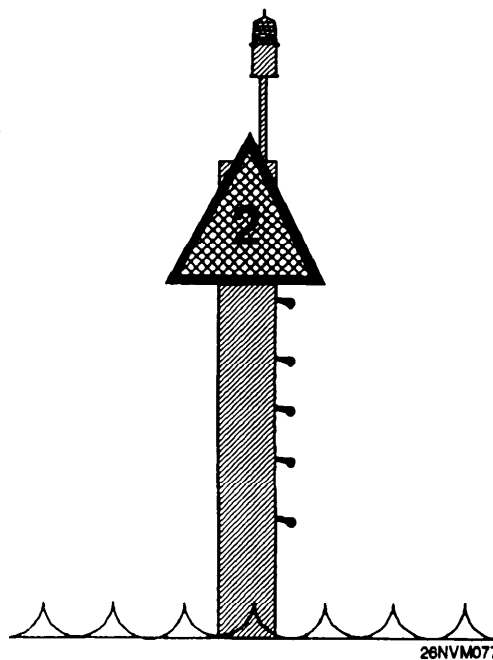

Figure 4-8. Minor light.

# Factors Associated with Navigational Lights

---

## Light Colors

There are only three light colors in common use on fixed lighted navigation aids--white, green, and red. All lighted navigation aids, regardless of the color of their light, are symbolized on a chart either by a magenta colored ray in the form of an exclamation point or by a one-eighth-inch magenta circle, superimposed over a black dot indicating the location of the light.

On charts, the color of the light, if other than white, is indicated by the abbreviations R for red and G for green, written near the light symbol. A white light has no abbreviation on a chart. Thus, if a magenta light symbol appears on a chart with no color abbreviation nearby, the navigator should assume its color to be white.

In the *Light List* and *List of Lights*, however, the color of a white light is indicated by the abbreviation W.

---

## Alternating Lights

If a light is made to change color in a regular pattern, either by alternately energizing different color lights or by passing colored lenses around the same light, the light is an alternating light, abbreviated Al.

Alternating lights used in conjunction with different phase characteristics show a very distinctive appearance that cannot be easily mistaken. Their use is generally reserved for special applications requiring the exercise of great caution, such as airport beacons, harbor entrance lights, and lighthouses.

# Sector Lights

---

## Information

Sectors of colored glass are placed in the lanterns of certain lighthouses to indicate danger bearings within which a ship will be in danger of running on rocks, shoals, or some other hazard. The arcs over which a red light shows are the danger sectors whose bearings usually appear on the chart. Although the light is red within the danger arc, its characteristics remain the same. It should be noted, however, that the red light within the red sector may not be as visible as the white light outside that sector.

Sectors may be only a few degrees in width, marking an isolated obstruction, or they may be so wide that they extend from the direction of deep water to the beach.

In most instances, red sectors indicate water areas to be avoided. A narrow green sector may signify a turning point or the best water across a shoal. Exact significance of each sector may be obtained from the chart.

Exercise caution so that the danger sectors are not mistaken for the sectors of good water or that incorrect bearings are taken from the chart.

All sector bearings are true bearings in degrees running clockwise around the light as a center and are expressed as BEARINGS OBSERVED FROM THE SHIP TOWARDS THE LIGHT.

Take a look at the example presented in figure 4-9. The *Light List* Remarks column shows Cape Henry Light (LLNR 365) as having a red sector from 154° to 233°. As long as your ship is within this sector, the light will appear red. In this same example you will also note that the nominal range of the red light is 15 miles, while the same light in the white sector has a nominal range of 17 miles. The reason for this difference is that a white light of a certain intensity is visible for a longer distance than a red light of the same intensity.

# Sector Lights, Continued

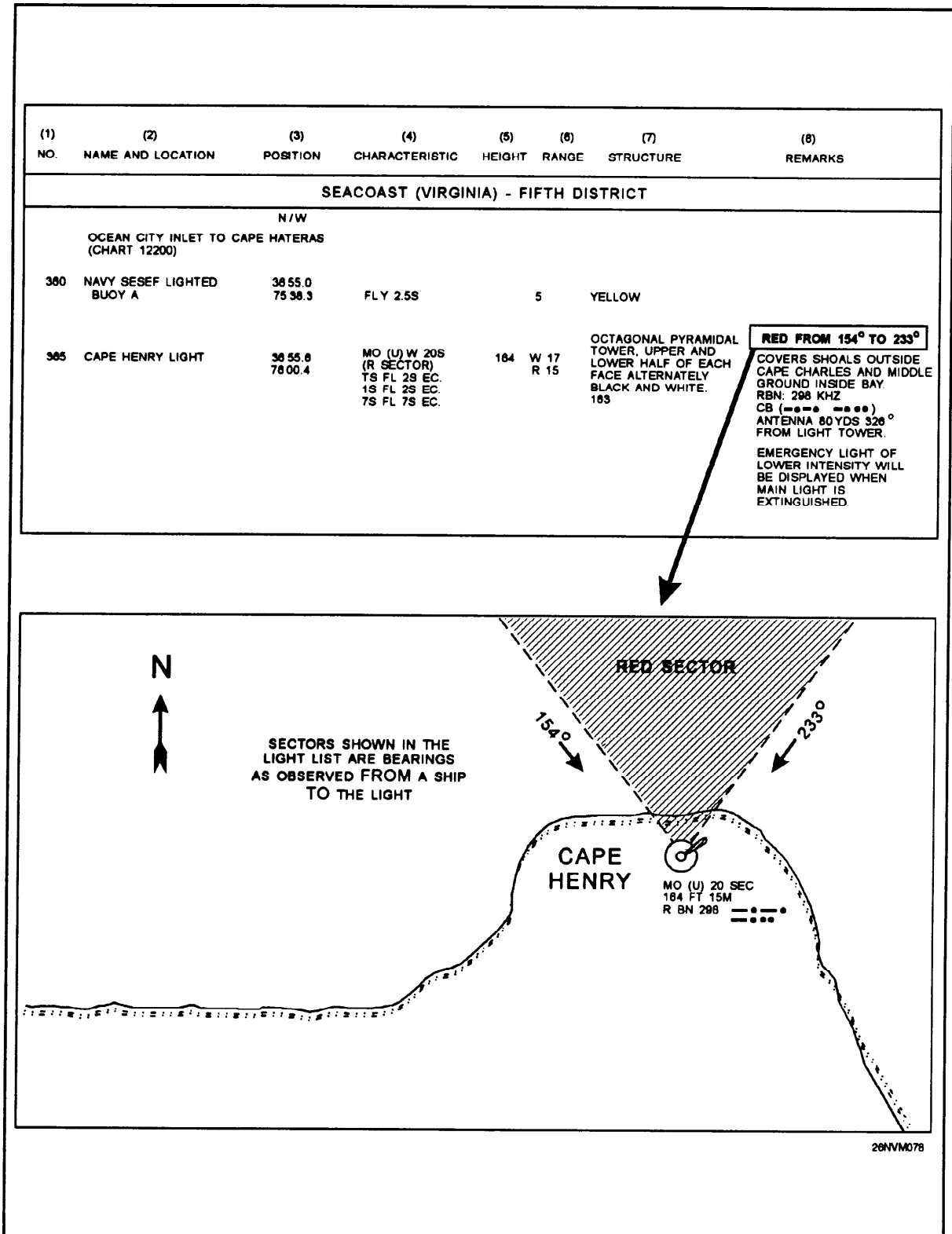

Figure 4-9. Light sectors are expressed as observed from the ship to the light.

## Sector Lights, Continued

---

**Sector Lights,  
continued**

On either side of the line of demarcation between colored and white sectors, there is always a small sector whose color is doubtful because the edges of a sector cannot be cut off sharply. Under some atmospheric conditions, a white light may have a reddish appearance. Consequently, light sectors must not be relied upon entirely; but position must be verified repeatedly by bearings taken on the light itself or by other fixed objects.

When a light is cut off (obscured) by adjoining land, the arc of visibility may vary with a ship's distance away from the light. If the intervening land is sloping, for example, the light may be visible over a wider arc from a far off ship than from one close inshore.

---

**Emergency  
Lights**

Emergency lights of reduced intensity are displayed from many primary lights when the main light is extinguished. These emergency lights may or may not have the same characteristic as the main light. The characteristic of the emergency lights are listed in column 8 of the *Light List*. Again, refer to the example shown in figure 4-9 for Cape Henry Light (LLNR 365).

---

**RACONs**

A RACON is a radar beacon that produces a coded response, or radar paint, when triggered by a radar signal. The coded response appears on your radar screen as a series of dots and dashes. RACONs are placed on important ATONs (buoys or structures) to assist in positive identification of the aid. Column 8 of the *Light List* will describe the RACON signal both as a Morse code letter and the equivalent dots and dashes, for example RACON: X (-..-).



# Buoys

---

## Buoys

Buoys are, in effect, floating sign posts for the mariner. Their color, shape, number, light, or sound characteristic tell the mariner how to transit safe water and avoid navigational hazards, and assist the mariner in following the proper course.

Buoy symbols shown on charts (see fig. 4-10) indicate the approximate position of the buoy and of the sinker that moors the buoy to the bottom. The approximate position is used because it is difficult to keep a buoy and its moorings in an exact geographical location. These difficulties include, but are not limited to, imprecise

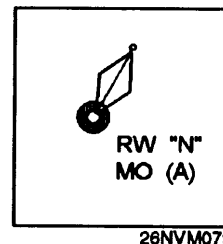

methods of position fixing, existing atmospheric and sea conditions, and variations in the seabed's slope and makeup. The position of the buoy can be expected to shift inside and outside the area shown on the chart because they are moored with excess chain. In addition, buoys and sinkers are normally checked only during periodic maintenance visits, which often occur more than a year apart.

Figure 4-10. Buoy symbol

---

## Types of Buoys

There are many different types of buoys in our buoyage system, with each type designed to meet certain requirements. All buoys assist mariners during daylight hours, and those with light, sound signals, or both, serve the mariner during darkness or periods of low visibility. The following are the principal types of buoys you will encounter:

Spar buoys are cylindrical in shape and are often constructed from large logs, which are trimmed, shaped, and appropriately painted. Some are metal, plastic, or fiberglass.

Can buoys (fig. 4-11) are built such that the upper portion that you observe resembles a can. These buoys are unlighted and will be painted green or have green and red horizontal bands.

Nun buoys (fig. 4-11) are built such that the upper portion you observe resembles a cone with a rounded tip. Like cans, these are also unlighted and will be painted red or have red and green horizontal bands.

Spherical buoys are unlighted and are round in shape. These buoys are painted with red and white vertical stripes.

# Buoys, Continued

**Types of Buoys** Bell buoys have a flat top, surmounted by a skeleton steel framework supporting a bell. The bell usually has four clappers, which strike the bell as the buoy moves with the sea.

Gong buoys are similar to bell buoys except they have a series of gongs, each with a different tone.

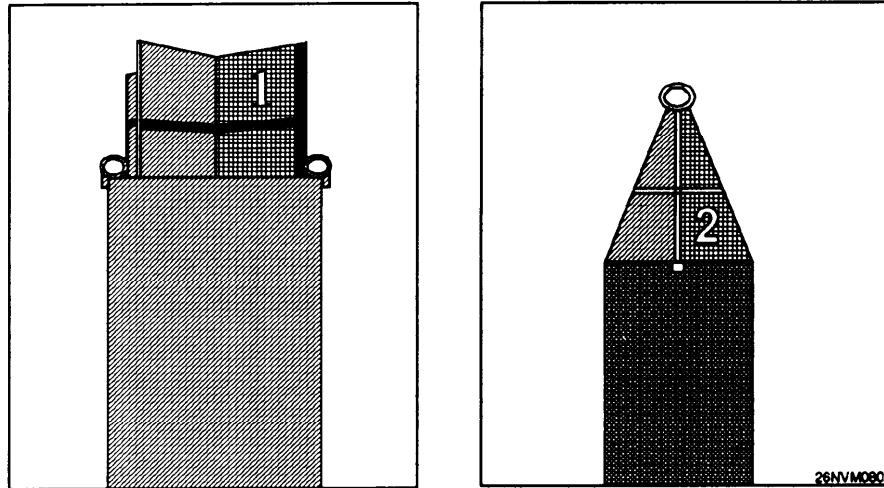

Figure 4-11. Can buoy on the left and nun buoy on the right.

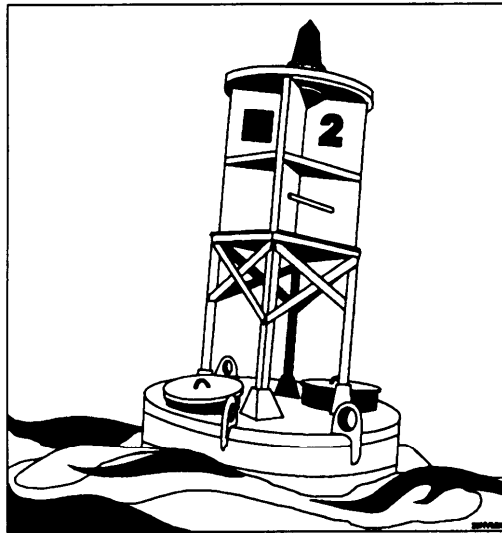

Figure 4-12. Lighted buoy.

## Buoys, Continued

---

**Types of Buoys**     Whistle buoys are similar to bell buoys except they carry a whistle sounded by the sea's motion or a horn that is sounded at regular intervals by electrical means.

Lighted buoys (fig. 4-12) carry batteries and are surmounted by a framework supporting a light. The framework has no navigational significance, it simply supports the light and sound equipment. Many lighted buoys carry a solar panel atop the light to recharge the battery during daylight hours.

Combination buoys have a combined light and sound signal, such as a lighted bell, gong, or whistle buoy. Some of the most important combination buoys also carry a RACON.

---

### **Large Navigational Buoys**

Large navigational buoys (LNBs) are disc-shaped buoys that may be as large as 40 feet in diameter.

LNBs provide a platform for a light, fog signal, radiobeacon, and meteorological sensors that transmit data ashore. LNBS were developed primarily to replace manned lightships and light towers.

They are normally stationed many miles from shore and are moved from time to time. Special attention must be paid to these buoys when laying coastal and open ocean tracks.

# Buoy Identification

---

## Information

All buoys are fitted with retroreflective materials that show well when illuminated with a spotlight, and most buoys are fitted with radar reflectors.

Retroreflective material is applied to lighted as well as unlighted buoys to increase their visibility. This application greatly assists you in locating aids at night using a searchlight. Retroreflective material may be red, green, white, or yellow; the coloring has the same significance as the colors of lights.

Many buoys are equipped with radar reflectors, which are vertical metal plates set at right angles to each other in such a manner as to greatly increase the echo returned to a radar receiver aboard ship. The plates are shaped and mounted in order to preserve the overall characteristic shape of an unlighted buoy or the general appearance of a lighted buoy. Some buoys have a radar reflector mounted inside the actual body of the buoy.

---

## CAUTION

Although buoys are valuable ATONs, you must never depend exclusively on them—they may fail. Some of the reasons for their failure are as follows:

Passing vessels may hit a buoy and shift it, overturn it, or set it adrift.

Buoys can drag their moorings in heavy weather.

The light on a lighted buoy may fail or be extinguished.

Sound signals may not function because of ice, storm damage, collisions, or other accidents.

Whistles, bells, and gongs actuated by the sea's motion may fail to function in smooth water. For these reasons, a prudent mariner must not rely completely upon the position or operation of buoys, but must also navigate using bearings from fixed structures and ATONs on shore.

# Buoyage Systems

---

**Systems** A buoyage system consists of fixed, floating, lighted, and unlighted ATONs. These aids are used to mark waterways. There are two buoyage systems that are in use throughout the world-the **lateral** system and the **cardinal** system.

---

**Lateral System** In the lateral system, aids are placed to mark the sides of a navigable channel. They also mark junctions and bifurcations, indicate the safe side on which to pass hazards, and mark the general safe centerline of wide bodies of water.

In U.S. waters, a vessel returning from seaward and proceeding toward the head of navigation is generally considered as moving southerly along the Atlantic Coast, westerly along the Gulf Coast, and northerly along the Pacific Coast. This is what is known as the "conventional direction" of buoyage. Virtually all U.S. lateral marks are located in what is known as IALA region B and follow the traditional "red right returning" rule.

---

**Cardinal System** In the cardinal system, aids generally mark the geographic relationship to the aid of a hazard in terms of 90-degree quadrants centered on the cardinal directions of north, east, south, and west. The cardinal system is not widely used in the United States and will not be discussed in this text. For more information on the cardinal system, consult *Dutton's Navigation and Piloting* or *Bowditch*.

# International Association of Light Authorities (IALA)

## Background

In years past, mariners had to be familiar with many different types of buoyage systems worldwide, because there was no standardized system in use. Some of the features of these different buoyage systems had completely opposite meanings, which often led to confusion and accidents. In the mid 1970's, the International Association of Lighthouse Authorities (IALA) developed and secured acceptance of two systems of buoyage known as IALA A and IALA B. Both systems use a combination of cardinal and lateral marks plus unique marks for isolated dangers, safe-water, and special-purpose areas.

## IALA Systems

The IALA system uses buoy shape, color, and, if lighted, rhythm of flashes to convey the desired information to the navigator. The system also uses special topmarks, which are small distinctive shapes above the basic aid to facilitate identification.

IALA System A is used in Europe, Africa, and most of Asia, including Australia and New Zealand. In this system, cardinal marks are widely used. Red buoys are kept to port when entering from seaward; green buoys are kept to starboard.

IALA system B is used in North, Central, and South America, Japan, South Korea, and the Philippines. Cardinal marks are permitted in this system but are seldom used. Red buoys are kept to starboard (red right returning) when entering from seaward, green buoys are kept to port. Figure 4-13 shows how the two IALA regions are divided worldwide.

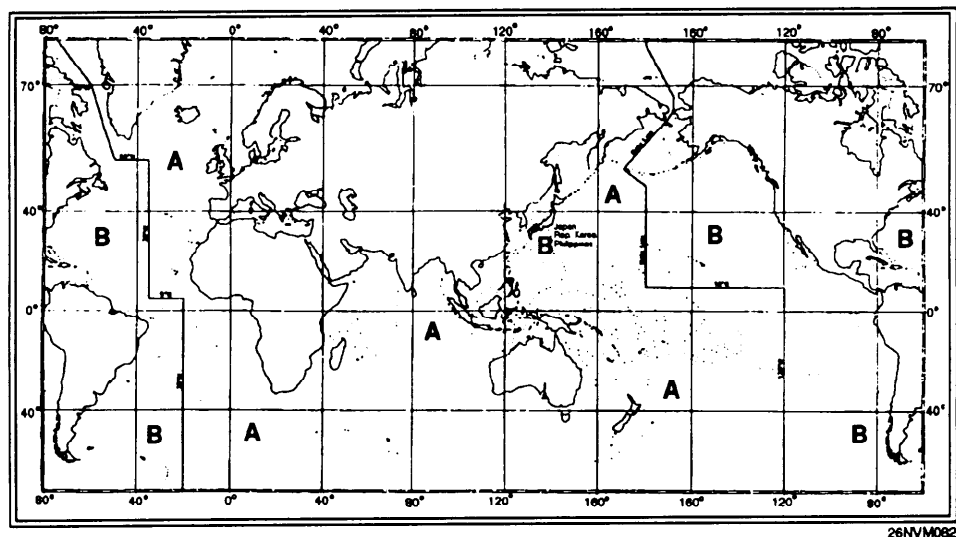

Figure 4-13. The IALA buoyage system.

# The United States System of Aids to Navigation

---

## Information

The system of ATONs used in the United States consists of buoys, lights, and daybeacons conforming to the IALA region B guidelines as well as certain variations which are used exclusively in this country. Figures 4-14 through 4-16 graphically display the variations that exist in the U.S. system.

Figure 4-14 shows the U.S. ATONs system as seen entering from seaward.

Figure 4-15 represents a visual buoyage guide for IALA region B.

Figure 4-16 shows how the visual guide would appear on a nautical chart.

Figure 4-17 shows ATONs as they appear on the western rivers of the United States.

# U.S. AIDS TO NAVIGATION SYSTEM

## on navigable waters except Western Rivers

### LATERAL SYSTEM AS SEEN ENTERING FROM SEAWARD

<p><b>PORT SIDE</b></p> <p><b>ODD NUMBERED AIDS</b></p> <ul style="list-style-type: none"> <li>GREEN LIGHT ONLY</li> <li>FLASHING (2)</li> <li>FLASHING</li> <li>OCCULTING</li> <li>QUICK FLASHING</li> <li>ISO</li> </ul> <p>1-6 FIG 46 LIGHTED BUOY</p> <p>G C-7 DAYMARK</p> <p>SG CAN</p>	<p><b>SAFE WATER</b></p> <p><b>NO NUMBERS - MAY BE LETTERED</b></p> <ul style="list-style-type: none"> <li>WHITE LIGHT ONLY</li> <li>MORSE CODE</li> </ul> <p>MO (A)</p> <p>RW 7N Mo (A)</p> <p>RW 7A N</p> <p>RW 7C SP C</p> <p style="text-align: center;">SPHERICAL</p>	<p><b>STARBOARD SIDE</b></p> <p><b>EVEN NUMBERED AIDS</b></p> <ul style="list-style-type: none"> <li>RED LIGHT ONLY</li> <li>FLASHING (2)</li> <li>FLASHING</li> <li>OCCULTING</li> <li>QUICK FLASHING</li> <li>ISO</li> </ul> <p>2-8 FIR 48 LIGHTED BUOY</p> <p>R Z DAYMARK</p> <p>NUN</p>
<p><b>PREFERRED CHANNEL</b></p> <p><b>NO NUMBERS - MAY BE LETTERED</b></p> <ul style="list-style-type: none"> <li>GREEN LIGHT ONLY</li> <li>RED LIGHT ONLY</li> </ul> <p>GR C F (2+1) G 6s</p> <p>RW 7N Mo (A)</p> <p>GR A</p>	<p><b>ISOLATED DANGER</b></p> <p><b>NO NUMBERS - MAY BE LETTERED</b></p> <ul style="list-style-type: none"> <li>WHITE LIGHT ONLY</li> <li>WHITE LIGHT ONLY</li> </ul> <p>F (2) 5s</p> <p>BR 1A F (2) 5s</p> <p>C</p>	<p><b>PREFERRED CHANNEL</b></p> <p><b>NO NUMBERS - MAY BE LETTERED</b></p> <ul style="list-style-type: none"> <li>RED LIGHT ONLY</li> </ul> <p>JR RG</p> <p>NUN</p> <p>NUN</p> <p>NUN</p>

**RANGE DAYMARKS - MAY BE LETTERED**

KWG	KWB	KRW	KRB	KRG	KGR	KBG	KBR	KRG	KGR

**DAYMARKS HAVING NO LATERAL SIGNIFICANCE**

MAY BE LETTERED

- NR
- RW
- Bn
- NG
- BW
- Bn
- NB
- WB
- Bn

**TYPICAL INFORMATION AND REGULATORY MARKS**

**EXCLUSION RESTRICTED DANGER OPERATIONS AREA**

**INFORMATION AND REGULATORY MARKERS WHEN LIGHTED, INFORMATION AND REGULATORY MARKS MAY DISPLAY ANY LIGHT RHYTHM EXCEPT QUICK FLASHING AND FLASHING (2)**

NW  WHITE LIGHT ONLY

**W DANGER**

Bn

**SPECIAL MARKS - MAY BE LETTERED**

**YELLOW LIGHT ONLY**

FIXED FLASHING

SHAPE OPTICAL - BUT SELECTED TO BE APPROPRIATE FOR THE POSITION OF THE MARK IN RELATION TO THE NAVIGABLE WATERWAY AND THE DIRECTION OF BUOYAGE.

**UNLIGHTED**

**UNLIGHTED**

Aids to navigation marking the Intracoastal Waterway (ICW) display unique yellow symbols to distinguish them from aids marking other waters. Yellow triangles indicate aids should be passed by keeping them on the starboard (right) hand of the vessel. Yellow squares indicate aids should be passed by keeping them on the port (left) hand of the vessel. A yellow horizontal band provides no lateral information, but simply identifies aids as marking the ICW.

Plate 1

Figure 4-14. Lateral system as seen entering from seaward.

THIS PAGE MUST BE PRINTED ON A COLOR PRINTER.



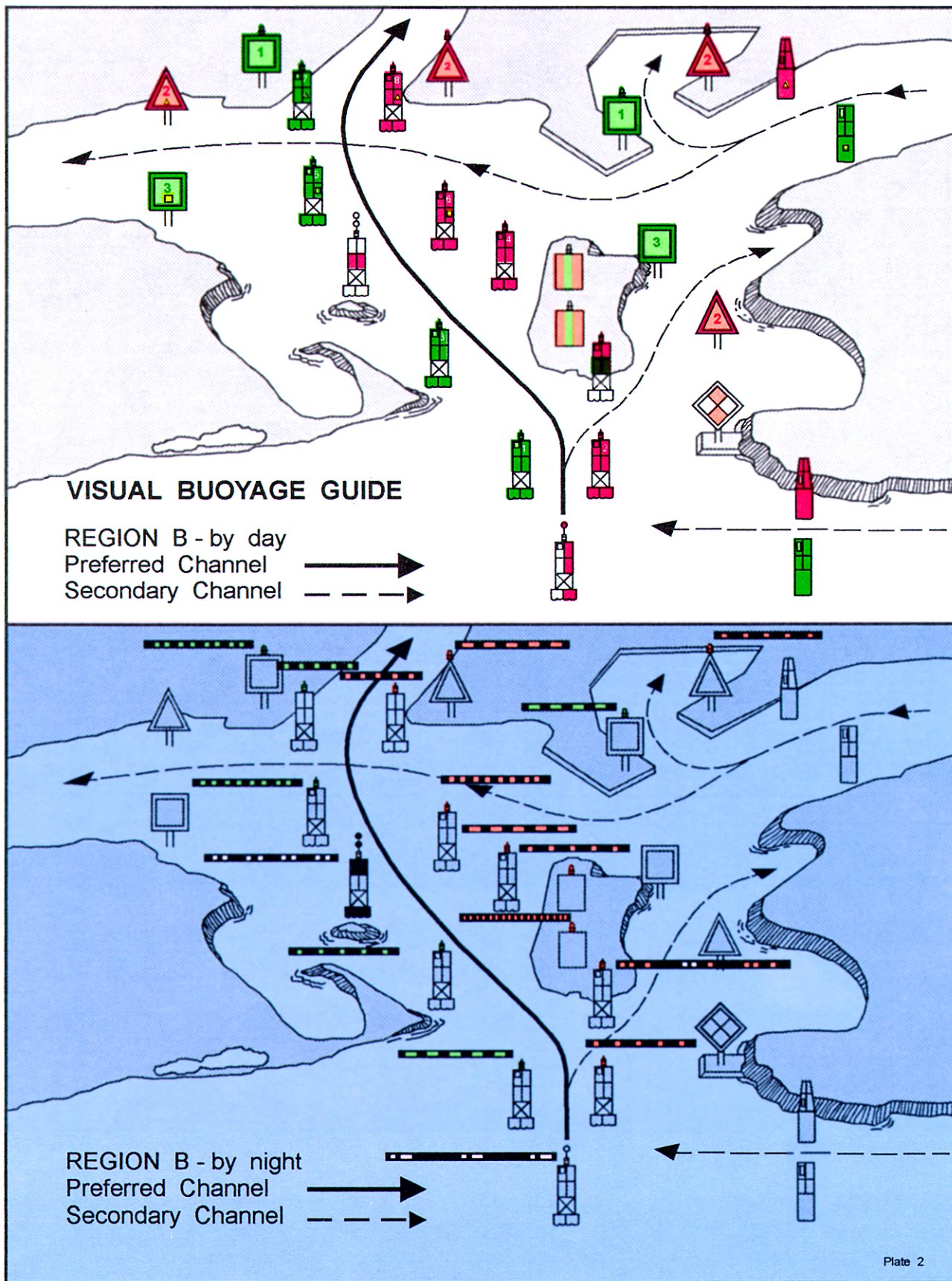

Figure 4-15. Visual buoyage guide for IALA region B.

# FICTITIOUS NAUTICAL CHART

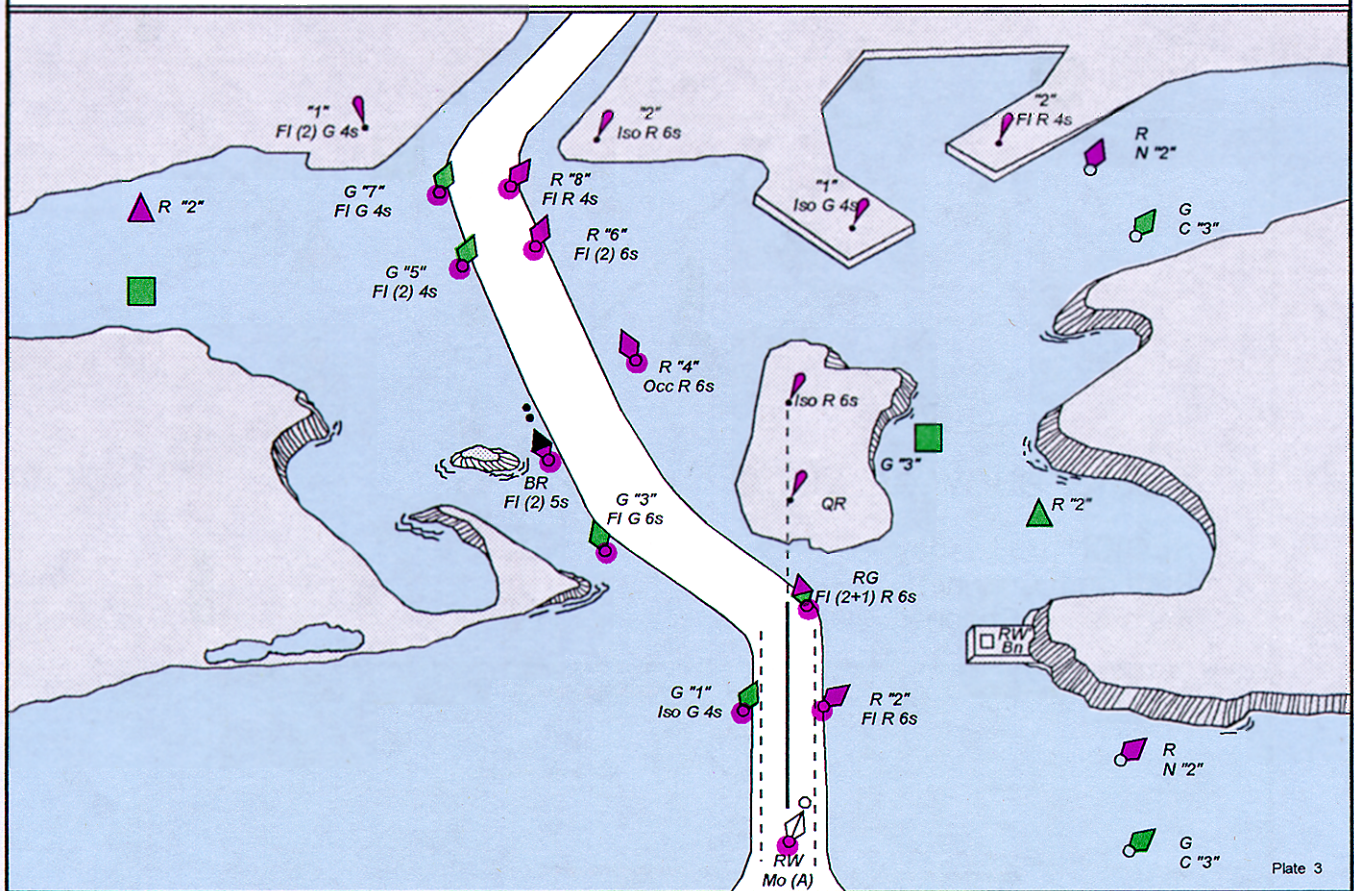

Figure 4-16. How the visual guide would appear on a nautical chart.

# U.S. AIDS TO NAVIGATION SYSTEM

## on the Western River System

AS SEEN ENTERING FROM SEAWARD

<p><b>PORT SIDE OR RIGHT DESCENDING BANK</b> GREEN OR WHITE LIGHTS (CROSSING) FLASHING (2)</p> <p>ISO</p> <p><b>176.9</b> MILEBOARD</p>	<p><b>PREFERRED CHANNEL TO STARBOARD</b> TOPMOST BAND GREEN FI (2+1) G</p> <p>MARK JUNCTIONS AND OBSTRUCTIONS COMPOSITE GROUP FLASHING (2+1)</p>	<p><b>STARBOARD SIDE OR LEFT DESCENDING BANK</b> RED OR WHITE LIGHTS (CROSSING) FLASHING (2)</p> <p>ISO</p> <p><b>123.5</b> MILEBOARD</p>
<p><b>PREFERRED CHANNEL TO SHARBOARD</b> TOPMOST BAND GREEN FI (2+1) G</p> <p>JG</p>	<p><b>PREFERRED CHANNEL TO PORT</b> TOPMOST BAND RED FI (2+1) R</p>	<p><b>DAYMARKS HAVING NO LATERAL SIGNIFICANCE</b></p> <p>MAY BE LETTERED</p> <p>UNLIGHTED</p> <p>YELLOW LIGHT ONLY FIXED FLASHING</p> <p>WHITE LIGHT ONLY</p> <p>LIGHTED</p>
<p><b>RANGE DAYMARKS - MAY BE LETTERED</b></p> <p>INFORMATION AND REGULATORY MARKERS WHEN LIGHTED, INFORMATION AND REGULATORY MARKS MAY DISPLAY ANY LIGHT RHYTHM EXCEPT QUICK FLASHING AND FLASHING (2)</p> <p>EXCLUSION AREA</p> <p>RESTRICTED OPERATIONS</p> <p>DANGER</p> <p>NW □ WHITE LIGHT ONLY</p> <p>DANGER</p>	<p><b>RANGE DAYMARKS HAVING NO LATERAL SIGNIFICANCE</b></p> <p>MAY BE LETTERED</p> <p>UNLIGHTED</p> <p>YELLOW LIGHT ONLY FIXED FLASHING</p> <p>WHITE LIGHT ONLY</p> <p>LIGHTED</p>	<p><b>STARBOARD SIDE OR LEFT DESCENDING BANK</b> RED OR WHITE LIGHTS (CROSSING) FLASHING (2)</p> <p>ISO</p> <p><b>123.5</b> MILEBOARD</p>

# UNIFORM STATE WATERWAY MARKING SYSTEM

STATE WATERS AND DESIGNATED STATE WATERS FOR PRIVATE AIDS TO NAVIGATION

<p><b>REGULATORY MARKERS</b></p> <p>SWIM AREA</p> <p>BOAT EXCLUSION AREA</p> <p>ROCK</p> <p>DANGER</p> <p>CONTROLLED AREA</p> <p>SLOW NO WAKE</p> <p>EXPLANATION: THE NATURE OF DANGER MAY BE INDICATED INSIDE THE CIRCLE. THE NATURE OF SWIM AREA, SWIM AREA, ROCK, WEIR, SHOULDER DAM, ANCHORAGE, ETC.</p> <p>INFORMATION FOR DISPLAYING INFORMATION SUCH AS DIRECTIONS, DISTANCES, LOCATIONS, ETC.</p> <p>MULLET LAKE</p> <p>BLACK RIVER</p> <p>BUOY USED TO DISPLAY REGULATORY MARKERS MAY SHOW WHITE LIGHT</p> <p>TYPE OF CONTROL IS INDICATED IN THE CIRCLE. THIS MARKER IS FOR NO WAKE ANCHORAGE, ETC.</p>	<p><b>AIDS TO NAVIGATION</b></p> <p>MAY SHOW GREEN REFLECTOR OR LIGHT</p> <p>3</p> <p>SOLID RED AND SOLID BLACK BUOYS</p> <p>USUALLY FOUND IN RIVERS PASS BETWEEN THESE BUOYS</p> <p>LOOKING UPSTREAM</p> <p>LATERAL SYSTEM</p> <p>STARBOW SIDE</p> <p>PORT SIDE</p> <p>MAY SHOW RED REFLECTOR OR LIGHT</p> <p>4</p> <p>RED-STRIPED WHITE BUOY</p> <p>MAY BE LETTERED</p> <p>DO NOT PASS BETWEEN BUOY AND NEAREST SHORE</p> <p>BLACK-TOPPED WHITE BUOY</p> <p>MAY BE NUMBERED</p> <p>PASS TO NORTH OR EAST OF BUOY</p> <p>RED-TOPPED WHITE BUOY</p> <p>PASS TO SOUTH OR WEST OF BUOY</p> <p>CARDINAL SYSTEM</p>	<p><b>MOORING BUOY</b></p> <p>WHITE WITH BLUE BAND</p> <p>MAY SHOW WHITE REFLECTOR OR LIGHT</p>
---	---	---

THIS PAGE MUST BE PRINTED ON A COLOR PRINTER.

Figure 4-17. Aids to navigation as they appear on the western rivers of the United States.

# Characteristics of Aids To Navigation

---

**Characteristics** The characteristics of ATONs include such things as color, light rhythms, cycle, number, and sound signal. In the pages that follow, we'll discuss these characteristics as they apply to the buoyage system used in the United States.

---

**Solid Colors** During daylight hours, the color of an aid to navigation tells you which side of a channel the aid marks, regardless of whether the aid is a buoy, light, or daybeacon. At night, the color of a lighted aid serves the same purpose. Only ATONs with green or red lights have lateral significance. When proceeding in the conventional direction of buoyage in IALA region B, you may see the following ATONs:

**Green** buoys (and lights and daybeacons with **square**-shaped green daymarks) mark the port side of a channel when returning from seaward. Green buoys will only have green lights.

**Red** buoys (and lights and daybeacons with **triangular**-shaped red daymarks) mark the starboard side of a channel when returning from seaward. This is the "red right returning" rule you may have heard of. Red buoys will only have red lights.

---

**Striped Buoys** **Green and red** (or red and green) **horizontally striped** buoys (daymarks for daybeacons and lights) are called **preferred-channel marks**. These aids are used to mark junctions (the point where a channel divides when proceeding seaward) or bifurcations (the point where the channel divides when proceeding from seaward). They may also be used to mark wrecks or obstructions that may be passed on either side. Here is how they are used in our buoyage system:

If the topmost band is **green**, keep the buoy to **port** to follow the preferred channel.

If the aid is a light or daybeacon and the topmost band is **green**, the daymarks will be **square**-shaped and the light color will be green regardless of the type.

If the topmost band is **red**, keep the buoy to **starboard** to follow the preferred channel.

If the aid is a light or daybeacon and the topmost band is **red**, the daymarks will be **triangular**-shaped and the light color will be red regardless of the type.

## Characteristics of Aids To Navigation, Continued

---

### Safe Water Marks

**Red and white vertically striped** buoys (daymarks for daybeacons and lights) are called **safe-water marks**. They are used to mark a mid-channel, fairway, or landfall. Safe-water marks have white lights.

**Black and red horizontally banded** buoys are called **isolated danger marks**. They are used to mark an isolated danger that has navigable water all around it. Isolated danger marks have white lights.

**Yellow** buoys and beacons are called **special-purpose marks**. They are used to mark anchorages, dredging, and fishnet areas. These aids have yellow lights.

**Nonlateral** aids are lights and daybeacons that have no lateral significance in our system of buoyage. Daymarks for these aids are diamond-shaped and will either be red and white, green and white, or black and white. The light color will always be white. These aids are used primarily as landmarks for navigation.

# Sound Signals

---

## Background Information

A *sound signal* is a term used to describe ATONs that produce an audible signal designed to assist the mariner in fog or other periods of reduced visibility. Sound signals can be activated by several means, such as manually, remotely, or by a fog detector device. It should be noted, however, that in patchy fog conditions, a fog detector may not always activate the signal.

Sound signals are distinguished by their tone and phase characteristics. The tones are determined by the devices producing the sound, such as a horn, bell, or gong. Phase characteristics are defined by the signal's sound pattern, or the number of blasts and silent periods per minute when operating. In the case of fixed structures, sound signals generally produce a specific number of blasts and silent periods every minute; buoy sound signals generally do not because the sound signal is generated by wave action.

The characteristic of a sound signal can be found in column 8 of the *Light List*. For example, for Chesapeake Light (LLNR 355) it reads "Horn: 1 blast ev 30<sup>s</sup> (3<sup>s</sup> bt)." What this means is that 30 seconds is the time required for one complete cycle to occur. During this 30-second cycle, there are 27 seconds of silence and 3 seconds of blast. You can time this cycle with a stopwatch just like a light. Timing a sound signal is another method of positively identifying an ATON. Unless it is specifically stated that a sound signal "Operates continuously," or the signal is a bell, gong, or whistle on a buoy, it can be assured that the sound signal only operates during fog, reduced visibility, or adverse weather.

**CAUTIONS TO OBSERVE IN USING SOUND SIGNALS:** Sound signals depend upon the transmission of sound through the air. As ATONs, they have certain inherent limitations that you must consider. Sound travels through air in a variable and unpredictable manner. At times, these signals may be completely inaudible even when close by. At other times, they may appear to be coming from a direction quite different than the actual bearing of the signal source. Mariners should not rely on sound signals to determine their positions.

# Intracoastal Waterway

---

## Information

The Intracoastal Waterway (ICW) is a largely sheltered waterway, suitable for year-round use, extending some 2,400 miles along the Atlantic and Gulf Coasts of the United States. In general, it follows natural waterways.

ATONs along the ICW have some portion of them marked with yellow. Otherwise, the coloring and numbering of the ATONs follow the same system as that in other U.S. waterways.

So vessels may readily follow the ICW, special markings consisting of yellow triangles and squares are employed. When you are following the ICW from the north along the Atlantic Coast and west along the Gulf Coast, aids displaying yellow triangles should be kept to starboard; those aids displaying yellow squares should be kept to port, regardless of the color of the aid on which they appear. Nonlateral aids in the ICW, such as ranges, safe-water, and other nonlateral daymarks, will be identified by the addition of a yellow stripe instead of a triangle or square.

The conventional direction of buoyage in the ICW is generally southerly along the Atlantic Coast and generally westerly along the Gulf Coast.

---

## Western Rivers

Aids to navigation on the western rivers of the United States--the Mississippi River and its tributaries above Baton Rouge, Louisiana, and on other certain rivers that flow towards the Gulf of Mexico--are generally similar to those on other U.S. waters, but there are a few differences that should be noted (see fig. 4-17).

ATONs are not numbered. Numbers on ATONs do not have lateral significance, but instead, indicate mileage from a fixed point.

Diamond-shaped crossing daymarks, red or green as appropriate, are used to indicate where the river channel crosses from one bank to another.

Lights on green aids show a single flash, which may be green or white. Lights on red aids show a double flash, which may be red or white. Isolated danger marks are not used.

This concludes our discussion on ATONs and the buoyage system. We now have information on the road signs of the nautical road. We can now take a look at the traffic laws, or as they are known, the Rules of the Road.

# Rules of the Road

---

## **Background Information**

As a Quartermaster, you are required to know how to operate your ship's sound signaling equipment. You must also be able to interpret whistle and bell signals as they apply to the rules of the road. The rules of the road are published by the Coast Guard in a booklet entitled Navigation Rules (COMDINST M16672.2B).

International Rules are specific rules for all vessels on the high seas and in connecting waters navigable by seagoing vessels. The Inland Rules apply to all vessels upon the inland waters of the United States and to vessels of the United States on the Canadian waters of the Great Lakes to the extent that there is no conflict with Canadian law.

The International Rules were formalized at the convention on the International Regulations for Preventing Collisions at Sea, 1972. These rules are commonly called 72 COLREGS. The Inland Rules discussed in this chapter replace the old Inland Rules, Western River Rules, Great Lakes Rules, their respective pilot rules, and parts of the Motorboat Act of 1940. Many of the old navigation rules were originally enacted in the last century. Occasionally, provisions were added to cope with the increasing complexities of water transportation. Eventually, the navigation rules for the United States inland waterways became such a confusing patchwork of requirements that in the 1960s several unsuccessful attempts were made to revise and simplify them.

Following the signing of the 72 COLREGS, a new effort was made to unify and update the various Inland Rules. This effort was also aimed at making the Inland Rules as similar as possible to the 72 COLREGS. The Inland Navigation Rules of 1980, now in effect, are the result. The International/Inland Rules contain 38 rules that comprise the main body of the Rules and five annexes which are the regulations. The International/Inland Rules are broken down in parts as follows:

- A-General
- B-Steering and Sailing Rules
- C-Lights and Shapes
- D-Sound and Light Signals
- E-Exemptions



# Steering and Sailing Rules

---

## Information

In this portion of the chapter a short discussion of the steering and sailing rules will be presented, but the majority of our discussion will be about part D, which contains the requirements for sound signals.

You must understand the steering and sailing rules and be able to apply them to various traffic situations. Although all rules of the road are important, the steering and sailing rules are the most essential to know to avoid collision. The risk of collision can be considered to exist if the bearing of an approaching vessel does not change appreciably.

**NOTE:** When you are approaching a very large vessel, or when you are in close quarters, a bearing change alone does not necessarily mean that a collision cannot happen.

Figures 4-18, 4-19, and 4-20 illustrate the three situations in which the danger of collision might exist: head-on, crossing, and overtaking. The illustrations and the following summary will help you learn the rules and the appropriate actions to take.

---

## Head On

When two ships meet head on, or nearly so (fig. 4-18), each ship must change course to starboard and pass port-to-port. In international waters, a whistle signal is sounded only when a course change is actually made. If the meeting ships are already far enough off each other to pass clear on their present courses, no signal is sounded.

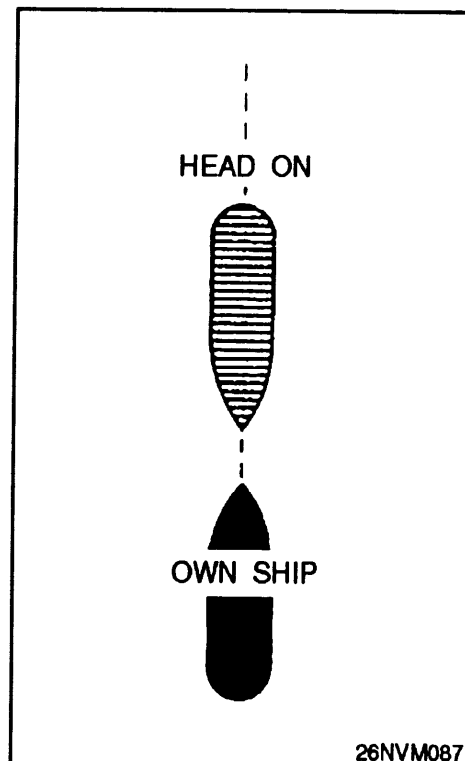
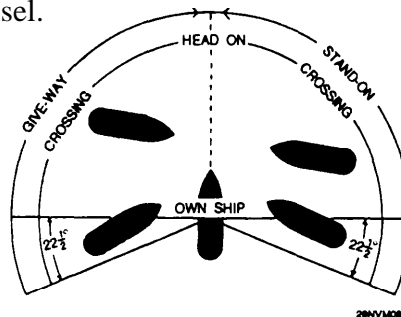

Figure 4-18. Ships in a head on situation.

# Steering and Sailing Rules, Continued

## Crossing

When two power-driven vessels are crossing and involve risk of collision (fig. 4-19), the vessel having the other to starboard must keep out of the way and will avoid usually by turning to starboard and passing astern of the other vessel or, if circumstances permit, speeding up and crossing ahead of the other vessel.



NOTE:  
VESSELS TO BE CONSIDERED IN  
RELATION TO OWN SHIP ONLY.  
COLLISION COURSE ASSUMED.

Figure 4-19. Two ships in a crossing situation.

A sailing vessel has the right-of-way over power-driven vessels except when the sailing vessel is overtaking, or when the power-driven vessel is engaged in fishing, is not under command, or is restricted in its ability to maneuver.

## Overtaking

Any vessel overtaking another must keep clear of the overtaken vessel. An overtaking vessel is one that is approaching another vessel from any direction more than 22.5 degrees abaft its beam (fig. 4-20). When in doubt, assume you are overtaking and act accordingly.

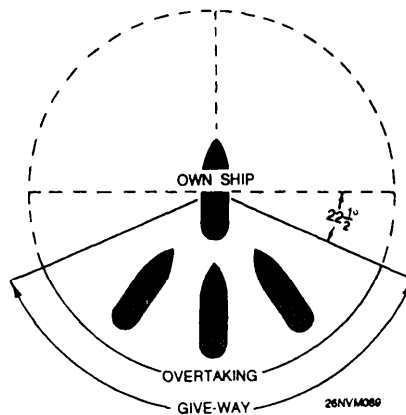

NOTE:  
VESSELS TO BE CONSIDERED IN  
RELATION TO OWN SHIP ONLY.  
COLLISION COURSE ASSUMED.

Figure 4-20. Two ships in all overtaking situation.

# Signals between Vessels

## Information

Before we get into the requirements for signals, you must first understand the terms we will use.

Term	Definition
Vessel	The word vessel includes every description of watercraft including nondisplacement and seaplanes, used or capable of being used as a means of transportation.
Power-Driven Vessel	Any vessel propelled by machinery.
Sailing Vessel	Any vessel under sail, provided that propelling machinery is not being used.
Engaged in Fishing	Any vessel fishing with nets, lines, trawls, or other apparatus that restrict maneuverability, does not include a vessel fishing with trolling or other fishing apparatus that do not restrict maneuverability.
Not Under Command	Any vessel that, through some exceptional circumstances, is unable to maneuver as required by rules and is therefore unable to keep out of way of another vessel (i.e. broke down).
Restricted in Its Ability to Maneuver	Any vessel that, from the nature of its work, is restricted in its ability to maneuver as required by these rules and is therefore unable keep out of the way of another vessel.
Constrained by Draft	A power-driven vessel that, because of draft in relation to the available depth of water, is severely restricted in its ability to deviate from the course it is following (International Rules)
Under Way	Any vessel not at anchor, made fast to the shore, pier, wharf, or aground.
Length and Breadth	A vessel's length overall and greatest beam or width.

## Signals between Vessels, Continued

## Signals between Vessels, Continued

Term	Definition
In Sight of One Another	Only when one can be seen from the other.
Seaplane	Any aircraft that maneuvers on the water.
Restricted Visibility	Any condition in which visibility is restricted by fog, mist, falling snow, heavy rainstorms, sandstorm, or any other similar causes.
Inland Waters	The navigable waters of the United States shoreward of the navigational demarcation lines dividing the high seas from harbors, rivers, and other such bodies of waters of the United States, and the waters of the Great Lakes of the United States side of the International Boundary.
Demarcation Lines	Lines delineating those waters upon which mariners must comply with the 72 COLREGS and those waters on which mariners must comply with the Inland Navigation Rules. (The boundaries for the demarcation lines are listed in the back of the Coast Guard publication Navigation Rules.)
Whistle	<p>Any sound signaling appliance capable of producing the prescribed blast and which complies with the specifications in Annex III of the International and Inland Rules. (When your ship was built and the whistle was installed, all of the specifications listed in Annex III were considered.)</p> <p>The term short blast means a blast of about 1-second duration.</p> <p>The term prolonged blast means a blast of from 4- to 6-second duration.</p>

# Maneuvering and Warning Signals

---

## Rules Regulating Sound and Light Signaling Equipment Required on Vessels

A vessel of 12 meters or more in length must be provided with a whistle and a bell. Vessels that are 100 meters or more in length must also have a gong. The tone of the gong cannot be confused with the tone of the bell. The bell and the gong must comply with the specifications listed in Annex III. As with the whistle, these specifications were taken into account when the ship was outfitted. A light may be used at night for signaling. The light must be, if fitted, an all-round white light, visible at a minimum range of 5 miles, and must comply with the provisions of Annex I to the International Rules.

A vessel of less than 12 meters in length will not be required to carry the signaling equipment described above, but must carry some efficient means of sound signaling.

---

## Supplemental Light Signals

When vessels are in sight of one another, that is, a power-driven vessel under way, maneuvering as authorized or required by these Rules, they must indicate that they are maneuvering by the following signals on the whistle. Any vessel may **supplement** the whistle signals prescribed by light signals, repeated as appropriate while the maneuver is being carried out.

Situation	Supplemental Light
Inland: I intend to leave you on my port side. Int'l: Altering course to starboard.	one flash
Inland: I intend to leave you on my starboard side. Int'l: Altering course to port.	two flashes
Inland and Int'l: Operating astern propulsion.	three flashes

## Maneuvering and Warning Signals, Continued

### Understanding the Intentions of Another Vessel

Vessels in sight of one another are approaching each other and either vessel fails to understand the intentions or actions of the other, or is in doubt whether sufficient action is being taken by the other vessel to avoid collision, the vessel in doubt must immediately indicate such doubt by giving at least **five short, rapid blasts on the whistle**. Such signal may be supplemented by a light signal of at least five short, rapid flashes.

Vessels nearing a bend or an area of a channel or fairway where other vessels may be obscured by an intervening obstruction must sound one prolonged blast. Such signal must be answered with a prolonged blast by any approaching vessel that may be within hearing around the bend or behind the intervening obstruction.

### Signals Required by Rule 34 of Navigation Rules

The following table lists the required sound signals required between vessels as stated in rule 34 of the *Navigation Rules*. The signals are made with the ship's whistle or the VHF radio. When using the VHF radio to exchange signals, use the words *1 whistle equals 1 short blast* and the words *2 whistles equal 2 short blasts*.

The International Rules do not require a reply from the receiving vessel except when being overtaken by another vessel, where if in agreement the overtaken vessel will sound 1 prolonged, 1 short, 1 prolonged, and 1 short blast in that order. The Inland Rules require the receiving vessel, if in agreement with the sending vessel, to sound the same signal in return. If, for any cause, the receiving vessel is in doubt of the proposed maneuver, the receiving vessel will sound 5 short blasts.

Signal	Condition	Meaning
1 short blast	Within 1/2 mile of another vessel.	Inland: I intend to leave you on my port side.
	When in sight of each other.	Int'l: I am altering my course to starboard.
2 short blasts	Within 1/2 mile of another vessel.	Inland: I intend to leave you on my starboard side.
	When in sight of each other.	Int'l: I am altering my course to port.
3 short blasts	Within 1/2 mile of another vessel.	Inland and Int'l: I am operating astern propulsion.

## Maneuvering and Warning Signals, Continued

Signal	Condition	Meaning
2 prolonged blasts followed by 1 short blast	Overtaking in narrow channel or fairway.	Int'l: I intend to overtake you on your starboard side.
2 prolonged blasts followed by 2 short blasts	Overtaking in narrow channel or fairway.	Int'l: I intend to overtake you on your port side.
1 short blast	Overtaking.	Inland: I intend to overtake you on your starboard side.
2 short blasts	Overtaking.	Inland: I intend to overtake you on your port side.
1 prolonged blast	Leaving a dock or berth.	Inland only: I am getting under way from a dock or berth.

### Signals Required by Rule 35 of Navigation Rules

Rule 35 of the *Navigation Rules* gives the signals required by vessels during periods of restricted visibility. The VHF radio cannot be used to send signals as prescribed by rule 35. The following table lists the required sound signals required between vessels as stated in rule 35 of the *Navigation Rules*. These signals are the same for both the Inland and International Rules.

Signal	Condition	Interval
1 prolonged blast	Power-driven vessel making way.	Not more than every 2 minutes.
2 prolonged blasts; 2 seconds apart	Power-driven vessel under way but stopped and making no way.	Not more than every 2 minutes.
1 prolonged blast followed by 2 short blasts	Not under command; a vessel restricted in its ability to maneuver, under way, or at anchor; a vessel engaged in fishing whether under way or at anchor; a vessel engaged in towing or pushing a vessel	Not more than every 2 minutes.
Rapid ringing bell for 5 seconds followed by 1 short, 1 prolonged, and 1 short blast.	At anchor. <b>Note:</b> In vessels over 100 meters in length, the bell will be sounded near the bow followed by a 5-second gong signal from the stem.	Not more than every 1 minute.

**Note:** Rule 35 also covers signals for towing and special circumstances. Refer to the *Navigation Rules* for complete details.

# Signals Used to Attract Attention

---

**Distress Signals** International Rules and Inland Rules on signals to attract attention are almost identical. If it becomes necessary to attract the attention of another vessel, any vessel may make light or sound signals that cannot be mistaken for any signal authorized elsewhere in these rules, or may direct the beam of its searchlight in the direction of the danger in such a way as not to embarrass any vessel.

The following paragraph from the International Rules is not included in the Inland Rules.

Any light to attract the attention of another vessel will be such that it cannot be mistaken for any aid to navigation. For the purpose of this rule, the use of high-intensity intermittent or revolving lights, such as strobe lights, must be avoided.

There is no basis in the rules of the road for the popular notion that the national ensign, hoisted upside down, is a recognized signal of distress. No man-of-war would ever subject the colors to this indignity. But if you should see a private craft with the ensign hoisted upside down, it is probably in distress. Signals covered by the International Rules and Inland Rules are as follows (fig. 4-21):

---

## **Special Submarine Signals**

The following signals, although not part of the rules of the road, are prescribed for submerged submarines in emergency situations involving rising to periscope depth or surfacing:

1. A white or yellow smoke flare fired into the air from a submarine indicates the submarine is coming to periscope depth to carry out surfacing procedures. Ships should clear the immediate vicinity but should not stop propellers.
2. A red smoke flare fired into the air from a submarine is a signal that the submarine is in serious trouble and will surface immediately if possible. Smoke flares of any color, fired into the air at short intervals, mean that the submarine requires assistance. All ships in the area should clear the immediate vicinity but stand by to give aid.



# Signals Used to Attract Attention, Continued

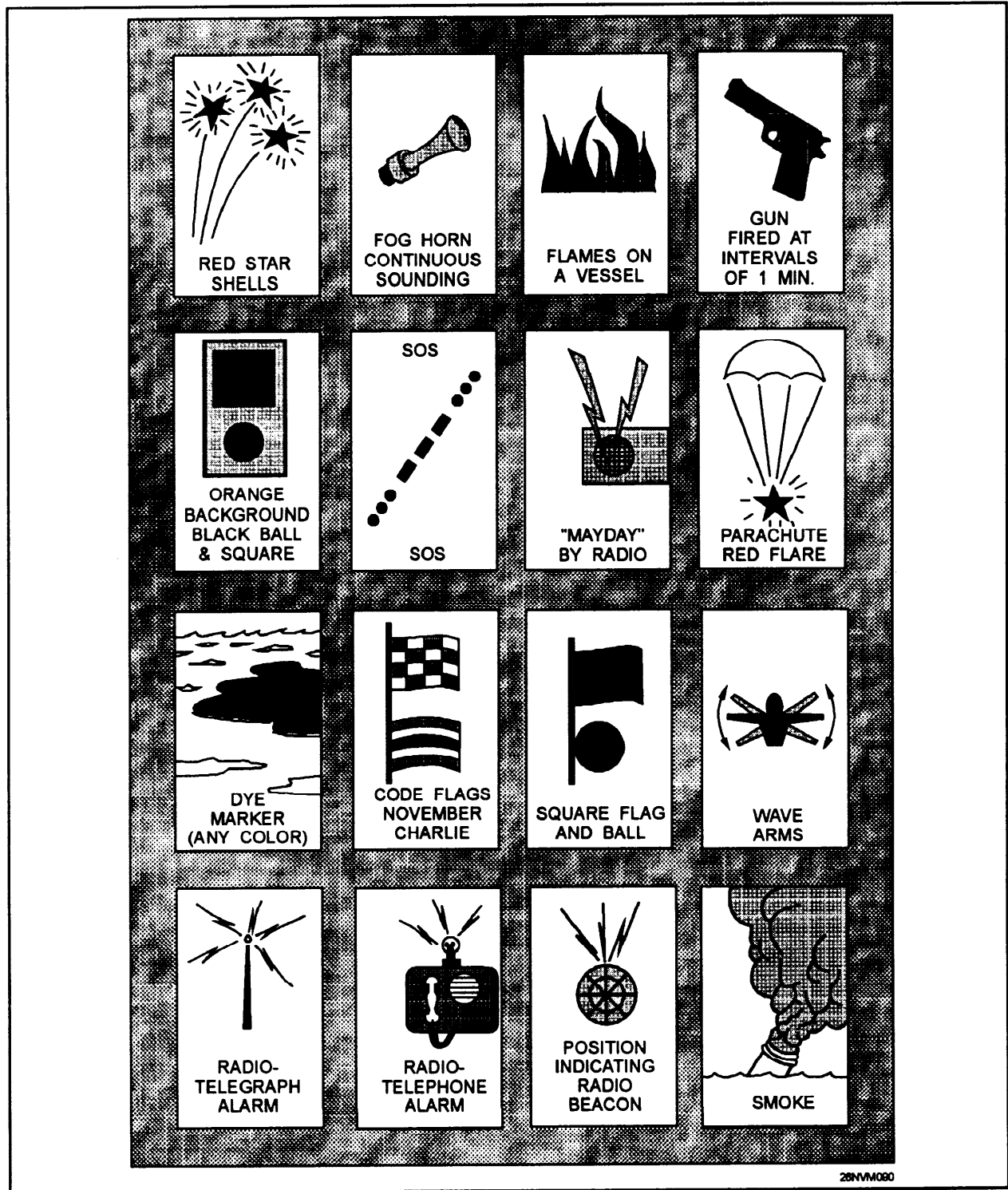

Figure 4-21. Distress signals.



# CHAPTER 5

## Basics of Time

---

### Introduction

In this chapter you will be introduced to the basics of time. You may be asking yourself what part time plays in the practice of navigation. You may be surprised to find out how important time actually is. For example, when we use time to mark the exact second of celestial observation an error of a few seconds could result in a fix error of many miles from the correct fix position.

---

### Objectives

The material in this chapter will enable the student to:

- Define the terms *apparent* and *mean* solar time.
- Match the following kinds of time with their definitions:
  - a. Greenwich mean time (GMT)
  - b. Universal time (UT)
  - c. Local mean time (LMT)
  - d. Zone time (ZT)
  - e. Zone description (ZD)
- State why standard time zones are used and how they are measured.
- Calculate ZD from ship's longitude.
- State the procedures for adjusting a ship's time and date at sea.
- Convert ZT to GMT.
- Convert GMT to ZT.
- Identify the equivalent values for arc and time.
- Convert time to arc and arc to time manually.
- Convert arc to time using *The Nautical Almanac*.

## Major Topics

---

<b>Topic</b>	<b>Page</b>
Apparent Time and Mean Solar Time	5-3
Definition of Terms	5-5
Standard Time Zones	5-6
The Relationship between Time and Longitude	5-7
How to Convert Arc to Time using <i>The Nautical Almanac</i>	5-10
How to Convert Time	5-11
Time and Date for Ships at Sea	5-13
Timepieces	5-14
Chronometer Error	5-15
Documenting Chronometer Error	5-17
How to Determine Daily Rates	5-18
Timing Celestial Observations	5-19

# Apparent Time and Mean Solar Time

---

## Background Information

In this section of the course, we will discuss time in more abstract terms. We will look at how time is measured, some basic terms and definitions associated with time, time zones and time zone conversions, and how we convert time to arc and arc to time.

The instrument for measuring time is a timepiece. Earth itself may be considered as our celestial timepiece. Each complete rotation of Earth on its axis provides a unit of time that we know as a day. Time is important to you because of its relationship to longitude. As a Quartermaster, you will have to understand this relationship to do your job.

---

## The Solar Day

The two types of time we will discuss here are:

1. Apparent solar time.
2. Mean solar time.

You probably already know that the motion of the Sun and the stars around Earth is only apparent--an illusion created by the rotation of the Earth itself. Solar time is based upon the rotation of the Earth with respect to the Sun.

*The solar day is equal to one rotation of Earth relative to the Sun.*

---

## Apparent Time

Apparent solar time is measured upon the basis of the apparent motion of the real Sun (the one you see rise and set every day). This is why we use the term *apparent* when we measure time using the apparent Sun. When the Sun is directly over our local meridian (directly overhead), we say that it is noon, local apparent time. When it is directly over the meridian that is  $180^\circ$  (on the opposite side of Earth) away from ours, it is midnight local apparent time.

If Earth remained stationary in space, all the days reckoned by apparent time would be of the same length. But Earth travels in an elliptical orbit around the Sun, and its speed relative to the Sun varies with its position in its orbit. Consequently, the time required for a complete revolution of Earth on its axis, although constant as applied to points on Earth, varies regarding Earth relative to the Sun. The length of a day measured by a complete revolution of Earth with regard to the Sun, also varies. For this reason it is impractical for man-made timepieces to keep apparent time; another solution had to be figured to account for these unequal lengths of time.

## Apparent and Mean Solar Time, Continued

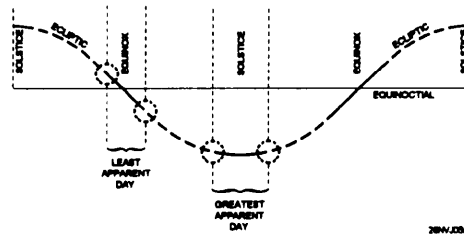

Figure 5-1 Difference in the time of an apparent day.

### Mean Solar Time

To remedy the situation created by apparent solar time, mean solar time was introduced. Mean solar time is based on a fictional Sun that is considered to move at a constant rate of  $360^\circ$  in 24 hours along the celestial meridian. One mean day is 24 hours in length, each hour consisting of 60 minutes, and each minute consisting of 60 seconds.

Mean solar time and apparent solar time are nearly equal, but mean solar time is the time used in everyday life (fig. 5-1). It is the time kept by our ship's chronometers and clocks, even our own wristwatch. It is also the time used in various almanacs that we use for tabulating the positions of celestial bodies.

### Equation of Time

The difference between the apparent day and the mean day is never more than a minute. This difference is cumulative and amounts to as much as a quarter-hour at certain times of the year (fig. 5-2 ). *The difference between mean and apparent time at any instant is called the equation of time.*

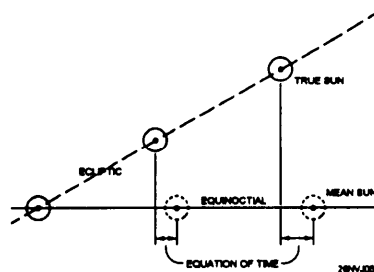

Figure 5-2. Difference of mean time and solar time.

## Definition of Terms

---

<b>GMT</b>	Greenwich mean time (GMT) is the basis or origin of longitude measurement. It is mean solar time measured with reference to the 0° meridian of longitude located at Greenwich, England. GMT is of prime importance to you because much of the time referenced in almanacs relates to GMT.
<b>UT</b>	When we discussed mean solar time we said that it was based on a fictional Sun that is considered to move at a constant rate of 360° in 24 hours along the celestial meridian. This solved the problem of unequal day length, but even with mean time there are slight variations. The most precise time yet developed by man is kept by atomic "clocks," which operate using cesium beam oscillators. This steady, internationally adjusted time is called Coordinated Universal Time (UTC). For our purposes, it is the same as GMT and is the time signal broadcast as radio time signals.
<b>LMT</b>	Local mean time is mean solar time measured with reference to your meridian; that is, the meridian where you are located.
<b>ZT</b>	Zone time is the time you use to set your watch and clocks. Zone time uses the standard (central) meridians of the various time zones as reference meridians.
<b>ZD</b>	The zone description of a time zone is the adjustment to be applied to that time zone to determine GMT.
<b>Discussion</b>	<p>Although most of the above terms may be new to you, they will all make sense when we cover the rest of the material in this chapter. In carrying out the daily routines you will often be required to convert time zones and work with time calculations. After a bit of practice, the procedures contained in this chapter will become second nature. In fact, in most cases you will learn to quickly do time calculation in your head.</p> <p>Let's move on to how time is broken down into standard meridians (zones) and then how that relates to longitude.</p>

# Standard Time Zones

## Introduction

You can understand how a general foul-up would result if all people set their watch on their own LMT. As you know, local mean time (LMT) always differs in different longitudes. In a large city, for example, a difference of about 9 seconds (9s) LMT occurs between one end of the city and the other end. If you set your watch on your LMT you would have to change it every time you went a few blocks on a street running east and west.

To eliminate this difficulty, standard time zones have been established within which all clocks are set to the same time, zone time (ZT). A difference of 1 hour (1h) takes place between one time zone and the next. Because 1h is  $15^\circ$ , you can see that each time zone comprises  $15^\circ$  of longitude. Thus resulting in 24 time zones, and 25 time zone designations.

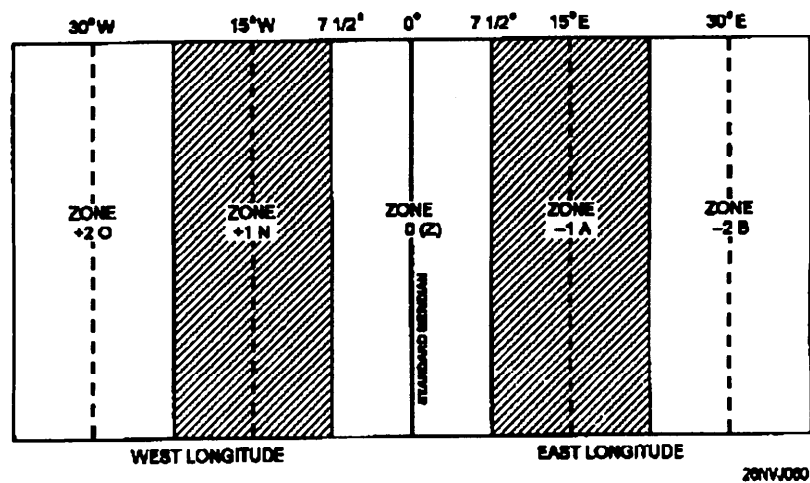

Figure 5-3. Time zones.

Local mean time along each standard time meridian is zone time for the entire time zone. Look at figure 5-3. In zone 0, time is exactly the same within  $7\ 1/2^\circ$  either side of the standard meridian. Zone time in navigation is abbreviated ZT.

Daylight savings time is simple zone time set ahead 1 hour to extend the time of daylight.



# The Relationship between Time and Longitude

---

## Background Information

Ordinarily, we use mean solar time, which is measured by the motion of the mean Sun around the Earth. Let's suppose your ship is on longitude  $60^{\circ}\text{W}$ . When the Sun is on your longitude or meridian, it is noon. As the Sun continues to move west and crosses over longitude  $61^{\circ}\text{W}$ , it is noon there and the time on your meridian is later. In fact it is the time equivalent of  $1^{\circ}$  later. But you can't measure  $1^{\circ}$  on your watch; you must convert this  $1^{\circ}$  of arc to units of time.

To have a standard reference point, every celestial observation is timed according to the time at the Greenwich meridian. Usually this is determined by means of the chronometer which is set to GMT. To clarify the relationship between time and arc, let's consider a situation in which you know your longitude exactly at noon, and you want to find out the time in Greenwich.

---

## Arc to Time

When the Sun is on a particular meridian, it is noon at that meridian. In other words, when the Sun is on the Greenwich meridian ( $0^{\circ}$ ), it is noon by Greenwich time. To make the problem easier, let's say you're in  $90^{\circ}\text{W}$  longitude. It's noon where you are, so the Sun must also be in  $90^{\circ}\text{W}$  longitude. So, since leaving Greenwich, the Sun has traveled through  $90^{\circ}$  of arc. Because it was 1200 (noon) Greenwich time when the Sun was at  $0^{\circ}$ , the time at Greenwich now must be 1200 plus the time required for the Sun to travel through  $90^{\circ}$  of arc.

The following information provides all the elements of a problem for converting arc to time. If you know that it takes 24 hours for the Sun to travel  $360^{\circ}$  or one complete revolution, it should be easy to find how long it takes it to go  $90^{\circ}$ . If the Sun goes  $360^{\circ}$  in 24 hours, it must go  $15^{\circ}$  in 1 hour. If it goes  $15^{\circ}$  in 1 hour, it must go  $1^{\circ}$  in 4 minutes. Then, to go  $90^{\circ}$ , it takes  $90 \times 4$  minutes, or 360 minutes, which is the same as 6 hours. Six hours ago it was 1200 Greenwich time; therefore, the time at Greenwich now must be 1800. You actually have converted  $90^{\circ}$  of arc to 6 hours of time. In doing so, you discovered the basic relationship between arc and time. This relationship is stated as  $15^{\circ}$  of longitude (arc) equals 1 hour of time.

Your problem could be converting time to arc--the reverse of the one we worked out. Tables for converting either way are in *The Nautical Almanac* and in *Bowditch*, but if you acquire the following easy methods of converting, you won't have to refer to publications. First, you must memorize the values for arc and time.

## The Relationship Between Time and Longitude, Continued

### ArctoTime Relationship

Use this table to learn the relationship between arc and time.

EQUIVALENTS OF ARC AND TIME	
Time to Arc	Arc to Time
$24\text{h} = 360^\circ$ $1\text{h} = 15^\circ$ $1\text{m} = 15'$ $1\text{s} = 15''$	$360^\circ = 24\text{h}$ $1^\circ = 4\text{m}$ $1' = 4\text{s}$

### Converting Time to Arc

The following is a step by step example of the time to arc conversion process:

Step	Action	Example: Convert 14h 21m 39s units of time to arc
1.	Multiply the hours by 15 to obtain degrees.	$14\text{h} \times 15 = 210^\circ$
2.	Divide the minutes by 4 to obtain degrees; multiply the remainder by 15 to obtain minutes of arc.	$21\text{m} \div 4 = 5^\circ 15'$ (remainder $1\text{m} \times 15 = 15'$ )
3.	Divide the seconds of time by 4 to obtain minutes and minutes of arc, or multiply the remainder by 15 to obtain seconds of arc.	$39\text{s} \div 4 = \underline{9' 45''}$ (remainder $3\text{s} \times 15 = 45''$ )
4.	Add degrees, minutes, and seconds.	Answer: $210^\circ 24' 45''$

*Continued on next page*

## The Relationship Between Time and Longitude, Continued

### Converting Arc to Time

The following table shows how to convert arc to time.

Step	Action	Example: Convert 215°24' 45" of arc to time.
1.	Divide the degrees by 15 to obtain hours, and multiply the remainder by 4 to obtain minutes of time.	$215^\circ \div 15 = 14\text{h}20\text{m}$
2.	Divide the minutes of arc by 15 to obtain minutes of time, and multiply the remainder by 4 to obtain seconds of time.	$24' \div 15 = 1\text{m}36\text{s}$ (remainder $5^\circ \times 4 = 20\text{m}$ )
3.	Divide the seconds of arc by 15 to obtain seconds of time.	$45'' \div 15 = \underline{\quad 3\text{s} \quad}$ (remainder $9' \times 4 = 36\text{s}$ )
4.	Add hours, minutes, and seconds.	Answer: 14h21m39s

### Finding ZD

To calculate the ZD for a given position, follow the steps as shown below.

Step	Action
1.	Divide the longitude of the position by $15^\circ$ .
2.	If the remainder is less than $7^\circ30'$ , the whole number quotient from step 1 equals the ZD.
3.	If the remainder is more than $7^\circ30'$ , the ZD is one more than the whole number of the quotient.

**Example 1:**  $135^\circ \text{ W} \div 15 = 9$  The longitude is west, so the ZD = +9.

**Example 2:**  $062^\circ \text{ W} \div 15 = 4$  with a remainder of 2. The remainder is LESS THAN  $7^\circ30'$  and the longitude is west, so the ZD = +4.

# How to Convert Arc to Time Using *The Nautical Almanac*

## Example

In the following example, you will learn how to convert arc to time using a table from *The Nautical Almanac*.

**Example:** Suppose your DR longitude is 142° 41' W, and ZT is 06h 21m 09s. Divide 142° 41' by 15, and you find that your ZD is +10. This means that your standard meridian must be 150°W. To simplify the arithmetic, express the 150°W longitude as 149° 60' W. The values are equal and subtraction is made easier this way.

Standard time meridian	149°60' W
Longitude your meridian	<u>142°41'</u>
Difference of Longitude	7°19'

Using the conversion of arc to time excerpt shown in figure 5-4, change 7° 19' to time, and you get 00h 29m 16s. This means that LMT at your meridian differs from ZT by 00h 29m 16s.

CONVERSION OF ARC TO TIME					
0°-59°		60°-119°		0' 00	
o	h	o	h	'	m s
0	00	60	40	0	00
1	04	61	40	1	04
2	08	62	40	2	08
3	12	63	41	3	12
4	16	64	41	4	16
5	20	65	42	15	10
6	24	66	42	16	14
7	28	67	42	17	18
8	32	68	43	18	12
9	36	69	43	19	16

Excerpt from page i of *The Nautical Almanac*

7 degrees =	0h 28m
19 minutes =	01m 16s
0h 29m 16s	

26NVJ061

Figure 5-4. Excerpt from *The Nautical Almanac*.

# How to Convert Time

## Converting ZT to GMT

In our previous discussion of ZD, we said that each standard meridian (those meridians exactly divisible by 15) is 1 hour apart and that each of these standard meridians is identified by a number and letter sign. To convert ZT to GMT, or GMT to ZT, the first thing you must determine is the correct ZD. ZT differs from GMT by the ZD.

**Rule:** When you convert ZT to GMT, you must apply the ZD to your ZT using the proper sign, minus (-) if you are in east longitude, plus (+) if in west longitude.

**Example 1:** Assume that you are in longitude 105°E, ZT is 16h 23m 14s, and you want to find GMT.

Step	Action
1.	Find your ZD. $105 \div 15 = 7$ .
2.	Determine the sign of the correction. You are in east longitude, so the sign is negative.
3.	Apply the correction. Your ZD is -7. The minus sign means that you subtract ZD from ZT to obtain GMT. $\begin{array}{r} \text{ZT } 16\text{h } 23\text{m } 14\text{s} \\ \text{ZD } -7 \underline{\hspace{1.5cm}} \\ \text{GMT } 09\text{h } 23\text{m } 14\text{s} \end{array}$

**Example 2:** Assume you are in longitude 75°W, ZT is 07h 13m 57s, and you want to find GMT.

Step	Action
1.	Find your ZD. $75 \div 15 = 5$ . Therefore, you are in zone 5.
2.	Determine the sign of the correction. You are in west longitude, so the sign is positive.
3.	Apply the correction. Your ZD is +5, so add the correction to ZT to obtain GMT. $\begin{array}{r} \text{ZT } 7\text{h } 13\text{m } 57\text{s} \\ +5 \underline{\hspace{1.5cm}} \\ \text{GMT } 12\text{h } 13\text{m } 57\text{s} \end{array}$

## How to Convert Time, Continued

### Converting GMT to ZT

When you convert GMT to ZT, you must apply the ZD to your ZT using the opposite sign; plus (+) if in east longitude, minus (-) if in west longitude.

**Example 1:** Assume that you are in longitude  $156^{\circ} 58'E$ , GMT is 01h 00m 00s on 01 July. You want to find ZT.

Step	Action
1.	Find your ZD. Divide $156^{\circ} 58'$ by 15 and you get 10.
2.	Determine the sign of the correction. You are in east longitude, so the sign is minus (-10).
3.	Apply the correction using the opposite  <div style="text-align: right; margin-right: 50px;">           GMT      01h 00m 00s            ZD      <u>  +10</u>            ZT      11h 00m 00s         </div>

**Example 2:** Assume that you are in longitude  $145^{\circ} 00' W$  and GMT is 16h 00m 00s on 30 December. You want to find ZT.

Step	Action
1.	Find your ZD. Divide $145^{\circ} 00'$ by 15 and you get 10.
2.	Determine the sign of the correction. You are in west longitude so the sign is plus (+10).
3.	Since you are going from GMT to ZT, apply the correction using the opposite sign (-10).  <div style="text-align: right; margin-right: 50px;">           GMT      16h 00m 00s            ZD      <u>  -10</u>            ZT      06h 00m 00s         </div>

# Time and Date for Ships at Sea

---

## Ship's Clocks

As your ship travels east or west at sea and passes between one time zone and the next, it is convenient for you (and everyone else on board) to adjust the ship's clocks to the time zone where you are actually located. As you pass from one time zone to the next, ZT changes by 1 hour. But do you advance the clocks 1 hour, or do you set them back 1 hour? The rule is:

If you are traveling towards the **west**, the new ZT will be 1 hour earlier; therefore, you must set the ship's clocks **back** 1 hour.

If you are traveling towards the **east**, ZT will be 1 hour later; therefore, you must set the ship's clocks **ahead** 1 hour.

The ship's navigator or quartermaster should notify the commanding officer when these changes become necessary. Do NOT, in any case, ever advance or retard the ship's chronometer.

---

## International Date Line

So far we've been talking about advancing or retarding clocks to account for time zone changes as we travel over the oceans. Suppose your ship is in the Pacific Ocean traveling west. As you continue to travel west, you are setting your clocks back 1 hour each time you enter a new time zone. Eventually, you will lose 24 hours in a circumnavigation of the Earth. Because of this, a method for adjusting for the day lost (or gained when you were traveling east) is necessary and is accomplished by the International Date Line, which follows the 180th meridian. The rule for changing date when crossing the International Date Line is:

When traveling **east** and crossing the International Date Line, you compensate by **retarding** the date 1 day.

When traveling west and crossing the International Date Line, you compensate by **advancing** the date 1 day.

**Note:** The date change is in the opposite direction to the hour changes you made as you passed into each new time zone. This date change is made by every vessel that crosses the International Date Line, regardless of the length of the voyage.

The International Date Line is used as a convenience just like time zones. Changing the date should take place at a convenient time that is least disruptive to the operation of your ship.

# Timepieces

---

## Introduction

The quartz chronometer is the main source for keeping shipboard time (fig. 5-5). A chronometer is like any watch except that it keeps time to a higher degree of accuracy. For detailed information on the components and upkeep of shipboard chronometers, refer to *NSTM*, chapter 252.

---

## Error and Rate

Even a chronometer cannot keep exact time indefinitely. Sooner or later the chronometer time gradually begins to draw away from GMT (UTC). The difference between chronometer time and GMT, at any instant, is called ***chronometer error***. Error direction is identified with a sign or letter (+ or F = Fast) or (- or S = Slow) to indicate that the chronometer is either fast or slow in relation to the correct GMT.

Chronometer rate, on the other hand, is the amount the instrument gains or loses in a specified time.

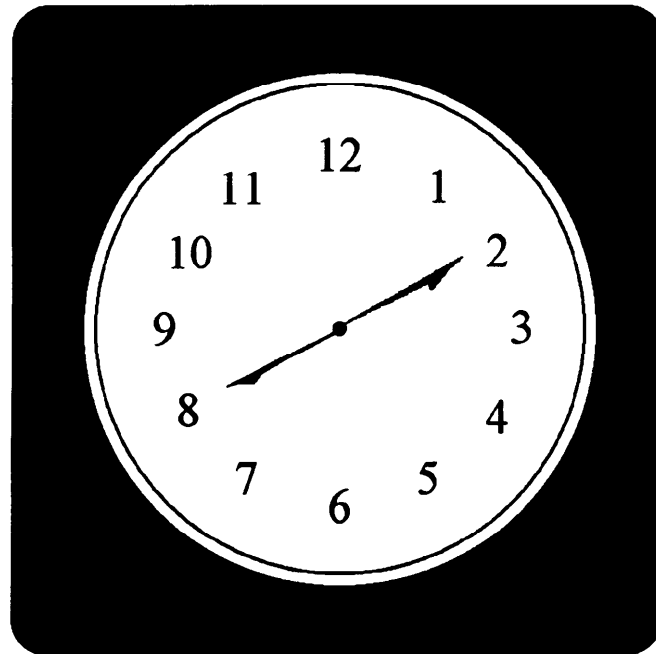

26NVJ062

Figure 5-5. Quartz chronometer.



# Chronometer Error

---

## Introduction

Inasmuch as chronometers are never reset aboard ship, an accumulated error may become quite large. Such an error is unimportant, though, if an accurate record is kept of the error. The most accurate check on the chronometer and other timepieces is by comparing the radio time signal broadcast by radio station WWV and other stations listed in *Radio Navigational Aids* (Pub No. 117) with the chronometer time.

---

## Time Ticks

Since 1 January 1973, the broadcast time signals (UTC) have differed from GMT by amounts up to  $\pm 0.7$ s. The difference arises because the times given in the navigational tables depend on the variable rate of rotation of the Earth, while the broadcast time signals are now based on an atomic time scale. Step adjustments of exactly 1 second are made to the time signals as required (normally at 24th on December 31 and June 30) so that the difference between the time signals and GMT may not exceed 0.9s. For those who require GMT to an accuracy better than 1s, a correction (DUT) is coded into the transmitted time signal. GMT accurate to 0.1s is obtained by applying DUT to the transmitted time signal; that is,

$$\text{GMT} = \text{UTC} + \text{DUT}$$

Naval radio stations transmit time signals (on seven different frequencies) for the 5 minutes immediately preceding certain hours GMT. The DUT correction is given in Morse code in the final 9-second pause prior to the long dash.

Each second in the time signal is marked by the beginning of a dash; the end of the dash has no significance. Beginning at 5 minutes before the hour, every second is transmitted except the 51st second of the 1st minute, 52nd second of the 2nd minute, 53rd second of the 3rd minute, 54th second of the 4th minute, 29th second of each minute, the last 4 seconds of each of the first 4 minutes, and the last 9 seconds of the last minute. The hour signal after the 0-second break (59m 60s) consists of a longer dash than the others. For clarity, the system of dashes are shown graphically in the accompanying table on the next page.

## Chronometer Error, Continued

---

Minute		Second									
	50 51	52	53	54	55	56	57	58	59	60	
		-	-	-	-			-			
55	-		-	-	-			-			
56	-	-		-	-			-			
57	-	-		-				-			
58	-										
59	- (+DUT)										

---

**Other Time Tick Available** All other time signal transmissions, for example, WWV (Ft. Collins, Colo.), WWVH (Honolulu), CHU (Ottawa, Can.), are broadcast on 2.5, 5, 10, 15, 20, and 25 megahertz and consist of dashes at the beginning of each second (commencing with the zero second of each minute). DUT is coded into the first 16 seconds by doubling of the dashes in seconds. 1 to 8 for +0.1s to +0.8s, and in seconds 9 to 16 for -0.1s to -0.8s. For example: If DUT = +0.4s, the dashes for seconds 1, 2, 3, 4 would be double; if DUT = -0.6s, the dashes for seconds 9, 10, 11, 12, 13, 14 would be double.

The upcoming time is announced during the interruption of the audio frequency. The exact time is taken the instant the audio frequency is resumed. An example of the voice announcement might be: "THIS IS RADIO STATION WWV. At the tone, the time will be 8 hours, 50 minutes, coordinated universal time."

## Documenting Chronometer Error

### Navigational Timepiece Rate Book

Information concerning each chronometer (error, successive daily rate, and average daily rate) must be recorded in the *Navigational Timepiece Rate Book*, NAVSEA 4270. (See fig. 5-6.) Each page of NAVSEA 4270 can accommodate the records of a maximum of three chronometers for 1 month.

### How to Check and Record Error

Use the following table to check and record chronometer error. You will need pencil, paper, and a comparing stopwatch handy.

Step	Action						
1.	Obtain a time tick signal from the communications center.						
2.	Determine from the time tick the next minute that will be sounded; write this value down. When the signal is sounded, start the comparing watch.						
3.	At the exact moment the comparing watch marks on the minute, note the exact time for chronometer 1. Write down the time for chronometer 1.						
4.	<p>Compare the two time values and determine the difference of time. It is always preferable to change the larger time value to ease addition or subtraction. In our example, the comparing watch time is the larger value and equals 1 lh 15m 00s. This converts to 11h 14m 60s.</p> <p><b>Example:</b></p> <table style="margin-left: 40px;"> <tr> <td>Comparing watch</td> <td>11h 14m 60s GMT</td> </tr> <tr> <td>Chrono time</td> <td>- 11h 14m 43s GMT</td> </tr> <tr> <td>Chrono error</td> <td>0h 00m 17s</td> </tr> </table>	Comparing watch	11h 14m 60s GMT	Chrono time	- 11h 14m 43s GMT	Chrono error	0h 00m 17s
Comparing watch	11h 14m 60s GMT						
Chrono time	- 11h 14m 43s GMT						
Chrono error	0h 00m 17s						
5.	Record results in the Timepiece Rate Book, compare the results with the previous day and compute the difference, assign a - value if the chronometer is slower; assign a + value if the chronometer is faster.						
6.	Repeat steps 1-5 for the remaining chronometers, replacing chronometer 1 with the chronometer you are comparing.						

### New Time Source

At the time of publishing of this TRAMAN, the use of GPS time as the single source reference for setting ships time has not been approved. However, the use of GPS time signals may be approved in the near future. Check with your Type Commander Staff Navigator for guidance on this matter.

# How to Determine Daily Rates

DATE		A				B				C				OBSERVATION	
YEAR	# 04	MAKE	HAMILTON			MAKE	HAMILTON			MAKE	HAMILTON			LOCAL TIME TO NEAREST MINUTE	
		TYPE	SC			TYPE	SC			TYPE	GCY				
		SERIAL NO.	4322			SERIAL NO.	1278			SERIAL NO.	843				
MONTH	July	ERROR RELATIVE TO G.C.T.	± MIN. SECONDS		SUCCESSIVE DAILY RATES	ERROR RELATIVE TO G.C.T.	± MIN. SECONDS		SUCCESSIVE DAILY RATES	ERROR RELATIVE TO G.C.T.	± MIN. SECONDS		SUCCESSIVE DAILY RATES	TIME	INITIALS
DAY		±			±			±		±			±		
1		+	1	4 5		-	2	4 6		+	12	42.6		1155	<del>   </del>
2		+	1	6 0	+ 1.5	-	2	3 8	+ 0.8	+	12	40.0	- 2.4	1205	<del>   </del>
3		+	1	7 5	+ 1.5	-	2	3 0	+ 0.8	+	12	37.5	- 2.5	1140	<del>   </del>
4		+	1	9 0	+ 1.5	-	2	2 2	+ 0.8	+	12	35.1	- 2.4	1135	<del>   </del>
5		+	1	10.6	+ 1.6	-	2	1 4	+ 0.8	+	12	32.7	- 2.4	1120	<del>   </del>
6		+	1	12.1	+ 1.5	-	2	0 5	+ 0.9	+	12	30.2	- 2.5	1200	<del>   </del>

26NVJ063

Figure 5-6. Excerpt from the Timepiece Rate Book.

## Average Daily Rate (ADR)

**Example:** a chronometer whose rate is +1.5 seconds will gain 1.5 seconds every 24 hours. Chronometer rate is usually expressed as seconds and tenths of seconds per day and is labeled *gaining* or *losing*. Chronometer rate is determined by comparing errors obtained several days apart and dividing the difference by the number of days between readings.

Date	Correct GMT (UTC)	Chrono. time	Error	Chrono. rate
17 July	11h 30m 00s	11h 32m 00s	02m 00s	
18 July	11h 30m 00s	11h 32m 01s	02m 01s	+1s

Average daily rate (ADR) is found by using the formula:

$$\text{ADR} = \frac{(\text{error on last day observed}) - (\text{error on first day observed})}{(\text{date of last observation}) - (\text{date of first observation})}$$

ADR formula for a 31-day month. A navigator desiring to determine the chronometer rate compares the chronometer directly with the Washington, D.C., (NSS) 1200 radio time signal on different days. On the first day the chronometer reads fast by 9 minutes 3.0 seconds and on the last day it reads fast by 9 minutes 53.5 seconds. ADR is found as follows:

$$\text{ADR} = \frac{(F) 09m 53.5s - (F) 09m 3.0s}{(31) - (1)} = \frac{50.5s \text{ diff}}{30 \text{ days}} = 1.68s/\text{gaining}$$

No attempt should be made to determine chronometer error closer than 1/2 (0.5) second. Average daily rates, therefore, are somewhat a more accurate measurement of the chronometer's performance than are the daily checks because, in the former method, any daily observational errors are averaged out.

# Timing Celestial Observations

---

## Background

The importance of obtaining the exact GMT (UTC) of every celestial observation was mentioned earlier. Obviously, it would be impractical if every time you took a sight on the bridge wing, you had to dash into the charthouse and look at the chronometer. Every observation, consequently, is timed the instant it is made, either by a stopwatch or by a comparing watch.

---

## Techniques

There are several methods available for timing observations. In this text we will cover the preferred method only. The preferred method consists of one person taking observations and another person marking the exact time of the observation. The person marking the time will need to use a comparing watch set to GMT from a time tick or set to chronometer time.

The stopwatch can be started exactly on some convenient minute or hour of the chronometer. If its rate is known to be small, there is no necessity for working out any chronometer minus watch (C-W) computation, provided the interval during which observations are taken is short. For a single observation, the stopwatch can be stopped (or, reversing the procedure, the watch may be started) when the sight is taken, but seldom is only one observation made. For this reason, the stopwatch must usually be read like any other watch.

A comparing watch can be set to the chronometer time and can be used to keep time if its rate is also small. Some navigators, though, prefer to keep their watches on zone time; hence, observation time must be computed. It doesn't matter whether computation is made before or after the observation. It is essential to have the interval as short as possible between time of sight and time of computation. Otherwise, enough time may elapse for the watch to gain or lose a sufficient amount to cause an error. For better accuracy and to avoid careless errors, it's a good idea to make C-W computations both before and after a round of sights.

## Timing Celestial Observations, Continued

---

### Techniques

The C-W computation is watch time (WT) to the half-second subtracted from chronometer time (CT). If WT is greater, 12 hours must be added to CT. The C-W is never greater than 12 hours because both watch and chronometer are graduated only to 12. Now that you know the value of C-W, it is necessary only to add this value to the WT of any observation to find the correct CT, then apply chronometer error (CE), and you have the GMT (UTC) of the observation.

---

### Examples

To work an example, assume that you have a chronometer whose error (CE) is -7m 4s; in other words, it is 7m 4s behind GMT (UTC). Your watch is set to ZT and reads 5h 26m 42s when the chronometer reads 10h 19m 00s. First, find the C-W. It's WT subtracted from CT.

CT	10h	19m	00s
WT	5h	76m	42s
C-W	4h	52m	18s

You step out on the bridge with our sextant and watch, and sight on Sirius at WT 5h 34m 21s, date 15 October, longitude 101°34.2'E. What should be the GMT (UTC) of this sight? Applying the formula  $CT = WT + C-W$ , we find:

WT	5h	34m	21s
CE		7m	04s
GMT	10h	33m	43s

Now, let's consider the date 15 October at 101°34.2'E. Is it the same day at Greenwich? Let's see. The ZT is 5h 34m 21s. The ZD is -7. Subtract ZD from ZT to get GMT (UTC). You can't subtract 7 from 5, but 5h on 15 October is the same as 29th on 14 October, and 7 from 29 is 22. Therefore, 1 Oh 33m 43s is not a.m. on 15 October, but p.m. on 14 October. From this computation, it follows that GMT (UTC) is 22h 33m 43s on 14 October.

In problems like these, you must check the date carefully every time to avoid a 12-hour error such as the one we encountered just now.

# Chapter 6

## Introduction to Celestial Navigation

---

### Introduction

In modern day navigation, we have grown dependent on advanced satellite navigation systems (GPS) to accommodate our day-to-day navigation needs. However, celestial navigation is still very much a part of a day's work in navigation. You may ask yourself why we still use celestial navigation with all the high tech equipment available to find the ship's position. The answer is simple. In wartime, there is always a possibility that satellite tracking stations and satellites themselves may be knocked out. As a Quartermaster, you must make every attempt to hone your celestial skills.

In this chapter, you will learn the basics of celestial navigation. The information contained in this chapter will help you to understand the more complex topics contained in chapter 9.

---

### Objectives

The material in this chapter will enable the student to:

- Describe the celestial sphere.
  - Describe the Celestial Coordinate System.
  - Use *The Nautical Almanac*.
  - Determine the LMT of sunrise, sunset, and twilight.
  - Determine LMT of moonrise and moonset.
  - Determine LHA of Aries, selected stars, and star time using *The Nautical Almanac*, Pub 249, and *The Rude Starfinder*.
- 

Topic	Page
Earth and the Celestial Sphere	6-2
Understanding the Celestial Coordinate System	6-3
Using <i>The Nautical Almanac</i>	6-5
How to Determine the Time of Sunrise, Sunset, and Twilight	6-6
How to Determine the Time of Moonrise and Moonset	6-8
How to Determine Selected Stars Using Pub 249	6-9
How to Determine Selected Stars Using <i>The Rude Starfinder</i>	6-12

# Earth and the Celestial Sphere

---

## Introduction

As you know, Earth is actually an oblate spheroid, just as with chart projections, we consider Earth a perfect sphere for celestial observations.

---

## Celestial Sphere

Simply stated, the celestial sphere is an imaginary sphere that stretches out to the ends of the universe. At the very center of the celestial sphere is Earth. As you know, Earth rotates on its axis from west to east. Because of this rotation, celestial bodies appear to be in motion, rising in the east then crossing over the observer's meridian and going on to set in the west.

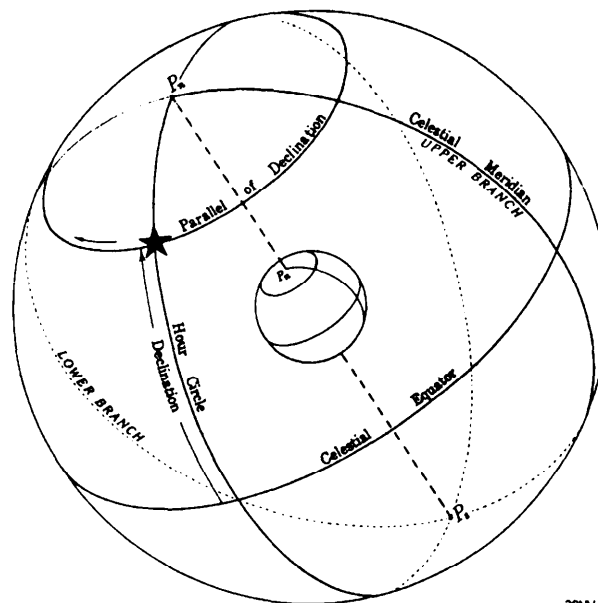

Figure 6-1. Celestial sphere revolving about Earth.

---

## Celestial Poles, Equator, and Meridians

The celestial poles are located by extending Earth's north and south poles (fig. 6-1). The celestial equator (also known as the *equinoctial*) is formed by extending Earth's equator out onto the celestial sphere. Meridians are formed by hour circles that are similar to great circles. The celestial meridian is formed by extending the Greenwich meridian out onto the celestial sphere.



# Understanding the Celestial Coordinate System

## Components

The Celestial Coordinate System is very similar to the Terrestrial Coordinate System. Use the following table and figure 6-2 to become familiar with the components of the Celestial Coordinate System.

Term	Description
Celestial Equator	The celestial equator is the point of reference for measuring <b>declination</b> .
Declination	Declination can be thought of as the celestial equivalent to latitude. Declination is expressed in the same manner as latitude, measured north or south from 0° through 90°.
First Point of Aries	The first point of Aries can be thought of as the reference point for measuring angles for stars and planets (celestial bodies).
Hour Circles	The great circles that encircle the celestial sphere in the same manner that meridians of longitude encircle Earth. The major <b>difference</b> is that hour circles are measured from 0° westward through 360°. As you know, longitude on the other hand is measured east or west from 0° through 180°. Hour circles move with each celestial body. The 0° meridian is called the <i>Greenwich meridian</i> .
Greenwich Hour Angle (GHA)	GHA is the angular measurement of a celestial body measured westward 0° through 360° from the Greenwich meridian.
Local Hour Angle (LHA)	LHA of a celestial body is measured westward from 0° through 360° from the observers meridian to the hour circle of the celestial body.
Sidereal Hour Angle (SHA)	The SHA is the hour circle of a star or planet measured westward from the first point of Aries from 0° through 360°.

## Understanding the Celestial Coordinate System, Continued

To help you visualize the celestial coordinate system, always imagine Earth at the center of the celestial sphere. These facts and figure 6-2 should help you visualize the celestial coordinate system.

### Facts

- The first point of Aries is the starting point for all celestial observations.
- Celestial bodies are in constant motion (that's why it was stressed in chapter 5 that the *exact time of a celestial observation must be recorded*).
- The use of GHA associates all hour circles of any celestial body with the Greenwich meridian on Earth. This allows all celestial bodies to be positioned at any moment on the celestial sphere.
- The GHA of Aries will align Aries with the Greenwich meridian.

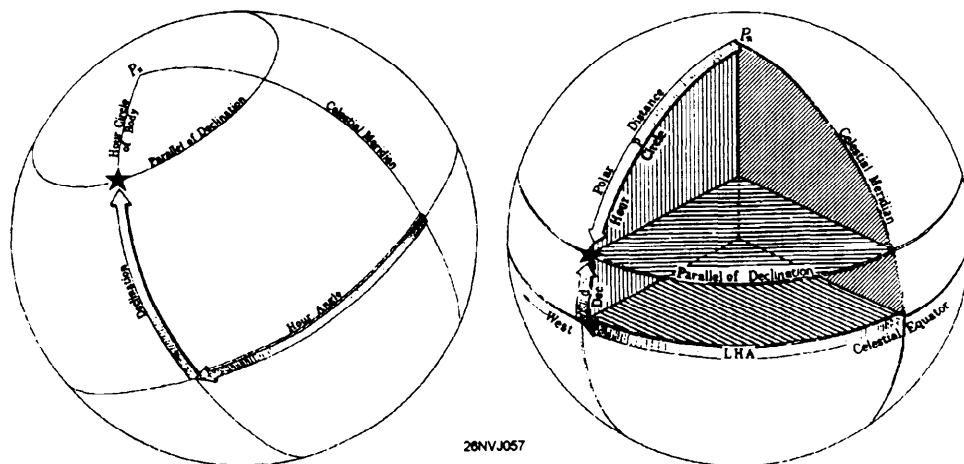

Figure 6-2. The celestial coordinate system.

## Using *The Nautical Almanac*

---

### **Format**

*The Nautical Almanac* is laid out in what are called daily pages. Each daily page contains astronomical data for 3 days. The left-hand pages contain values for GHA and Dec. (declination) for Aries, Venus, Mars, Jupiter, Saturn, and the 57 navigational stars. The right-hand pages contain values for GHA, Dec., sunrise, sunset, moonrise, moonset, the time of meridian passage for the Sun, and equation of time.

The inside cover contains altitude correction tables for the Sun, stars, and planets, and values for the dip of the horizon correction. After the daily pages are instructions for sight reduction, arc to time conversion table, and interpolation tables, and on the inside back cover are altitude correction tables for the Moon.

Figure 6-3 contains excerpts from *The Nautical Almanac*. As we work through practical examples in celestial navigation, you will learn how to use the information in *The Nautical Almanac*.

108										1991 MAY 28, 29, 30 (TUES., WED., THURS.)									
UT (GMT)	ARIES		VENUS -4.2		MARS +1.6		JUPITER -1.9		SATURN +0.5		STARS		Name		S.M.A.		Dec.		
	G.M.A.	Dec.	G.M.A.	Dec.	G.M.A.	Dec.	G.M.A.	Dec.	G.M.A.	Dec.	G.M.A.	Dec.	Name	S.M.A.	Dec.	S.M.A.	Dec.		
28 00	245 02.3	132 15.9	N24 27.8	121 34.4	N21 25.1	114 02.0	N18 53.2	295 48.1	518 56.8	Acomar	315 31.2	S40 28.2	315 31.2	S40 28.2					
01	240 04.8	147 13.5	27.3	136 37.3	24.7	129 04.1	53.1	310 50.6	56.8	Achernar	335 39.3	S57 16.5	335 39.3	S57 16.5					
02	275 07.3	162 15.1	26.9	151 30.2	24.4	144 06.1	53.0	325 53.1	56.8	Acrux	173 27.7	S63 03.5	173 27.7	S63 03.5					
03	290 09.7	177 14.7	26.5	166 39.2	24.0	159 08.2	52.9	340 55.6	56.8	Adhara	235 25.8	S27 57.7	235 25.8	S27 57.7					
04	305 12.2	192 14.3	26.0	181 40.1	23.7	174 10.3	52.8	355 58.1	56.8	Aldebaran	291 08.7	N16 29.6	291 08.7	N16 29.6					
05	320 14.7	207 13.9	25.6	196 41.0	23.4	189 12.4	52.7	11 00.6	56.8										
06	335 17.1	222 13.5	N24 25.2	211 42.0	N21 23.0	204 14.5	N18 52.6	26 03.1	518 56.9	Albath	166 34.6	N56 00.5	166 34.6	N56 00.5					
07	350 19.6	237 13.1	24.7	226 42.9	22.7	219 16.5	52.5	41 05.7	56.9	Alhaid	153 11.4	N49 21.4	153 11.4	N49 21.4					
T 08	5 22.1	252 12.8	24.3	241 43.9	22.3	234 18.6	52.4	56 08.2	56.9	Al Ma'ir	28 04.2	S46 59.9	28 04.2	S46 59.9					
U 09	20 24.5	267 12.4	23.9	256 44.8	22.0	249 20.7	52.3	71 10.7	56.9	Alnilam	276 03.4	S 1 12.4	276 03.4	S 1 12.4					
E 10	35 27.0	282 12.0	23.4	271 45.7	21.7	264 22.8	52.2	86 13.2	56.9	Alpheratz	218 12.4	S 8 37.4	218 12.4	S 8 37.4					
S 11	50 29.5	297 11.6	23.0	286 46.7	21.3	279 24.9	52.1	101 15.7	56.9										
D 12	65 31.9	312 11.2	N24 22.6	301 47.6	N21 21.0	294 26.9	N18 52.0	116 18.2	518 57.0	Alphacca	126 24.6	N26 44.5	126 24.6	N26 44.5					
A 13	80 34.4	327 10.8	22.1	316 48.5	20.6	309 29.0	51.9	131 20.7	57.0	Alphazet	358 00.8	N29 02.5	358 00.8	N29 02.5					
Y 14	95 36.8	342 10.5	21.7	331 49.5	20.3	324 31.1	51.8	146 23.2	57.0	Alpir	146 23.2	N 8 50.6	146 23.2	N 8 50.6					
15	110 39.3	357 10.1	21.2	346 50.4	19.9	339 33.2	51.7	161 25.7	57.0	Ankaa	353 32.0	S42 20.9	353 32.0	S42 20.9					
16	125 41.8	12 09.7	20.8	1 51.3	19.6	354 35.2	51.6	176 28.2	57.0	Antares	112 46.2	S26 24.9	112 46.2	S26 24.9					
17	140 44.2	27 09.3	20.4	16 52.3	19.2	369 37.3	51.5	191 30.7	57.0										
18	155 46.7	42 09.0	N24 19.9	31 53.2	N21 18.9	24 39.4	N18 51.4	206 33.3	518 57.1	Arcturus	146 10.4	N19 13.5	146 10.4	N19 13.5					
19	170 49.2	57 08.6	19.5	46 54.1	18.6	39 41.5	51.3	221 35.8	57.1	Atira	108 02.4	S69 00.9	108 02.4	S69 00.9					
20	185 51.6	72 08.2	19.0	61 55.1	18.2	54 43.5	51.2	236 38.3	57.1	Avior	234 25.2	S59 29.2	234 25.2	S59 29.2					
21	200 54.1	87 07.8	18.6	76 56.0	17.9	69 45.6	51.1	251 40.8	57.1	Bellatrix	278 50.0	N 6 20.6	278 50.0	N 6 20.6					
22	215 56.6	102 07.3	18.1	91 57.0	17.5	84 47.7	51.0	266 43.3	57.1	Betelgeuse	271 19.5	N 7 24.4	271 19.5	N 7 24.4					
23	230 59.0	117 07.1	17.7	106 57.9	17.2	99 49.8	50.9	281 45.8	57.1										
29 00	246 01.5	132 06.7	N24 17.2	121 58.8	N21 16.8	114 51.9	N18 50.8	296 48.3	518 57.2	Canopus	264 04.0	S52 41.6	264 04.0	S52 41.6					
01	261 04.0	147 06.4	16.8	136 59.8	16.5	129 53.9	50.7	311 50.8	57.2	Capella	280 59.4	N45 59.5	280 59.4	N45 59.5					

109										1991 MAY 28, 29, 30 (TUES., WED., THURS.)									
UT (GMT)	SUN		MOON				Lat.	Twilight		Sunrise	Moonrise								
	G.M.A.	Dec.	G.M.A.	°	Dec.	d		M.P.	Naut.		Civil	28	29	30	31				
28 00	180 43.4	N21 20.6	7 13.9	10.8	S24 06.9	4.6	54.5	N 72	□	□	□	□	□	□	□	□	□	□	
01	195 43.3	21.0	21 43.7	10.8	24 11.5	4.5	54.5	N 70	□	□	□	□	□	□	□	□	□	□	
02	210 43.2	21.4	36 13.5	10.7	24 16.0	4.3	54.5	68	□	□	□	□	□	□	□	□	□	□	
03	225 43.2	21.8	50 43.2	10.8	24 20.3	4.3	54.4	66	□	□	□	□	□	□	□	□	□	□	
04	240 43.1	22.3	65 13.0	10.7	24 24.6	4.1	54.4	64	□	□	□	□	□	□	□	□	□	□	
05	255 43.0	22.7	79 42.7	10.6	24 28.7	4.0	54.4	62	□	□	□	□	□	□	□	□	□	□	
06	270 42.9	N21 23.1	94 12.3	10.7	S24 32.7	3.9	54.4	60	□	□	□	□	□	□	□	□	□	□	
07	285 42.9	23.5	108 42.0	10.6	24 36.6	3.7	54.4	N 58	□	□	□	□	□	□	□	□	□	□	
T 08	300 42.8	23.9	123 11.6	10.6	24 40.3	3.7	54.4	56	□	□	□	□	□	□	□	□	□	□	
U 09	315 42.7	24.3	137 41.2	10.6	24 44.0	3.5	54.4	54	□	□	□	□	□	□	□	□	□	□	
E 10	330 42.6	24.7	152 10.8	10.6	24 47.5	3.4	54.4	52	□	□	□	□	□	□	□	□	□	□	
S 11	345 42.6	25.1	166 40.4	10.6	24 50.9	3.3	54.4	50	□	□	□	□	□	□	□	□	□	□	
D 12	0 42.5	N21 25.5	181 10.0	10.5	S24 54.2	3.1	54.4	48	□	□	□	□	□	□	□	□	□	□	
A 13	15 42.4	25.9	195 39.5	10.5	24 57.3	3.1	54.3	46	□	□	□	□	□	□	□	□	□	□	
Y 14	30 42.3	26.3	210 09.0	10.5	25 00.4	2.9	54.3	44	□	□	□	□	□	□	□	□	□	□	
15	45 42.3	26.7	224 38.5	10.5	25 03.3	2.8	54.3	42	□	□	□	□	□	□	□	□	□	□	
16	60 42.2	27.1	239 08.0	10.5	25 06.1	2.6	54.3	N 40	□	□	□	□	□	□	□	□	□	□	
17	75 42.1	27.5	253 37.5	10.5	25 08.7	2.4	54.3	38	□	□	□	□	□	□	□	□	□	□	
18	90 42.0	N21 27.9	268 07.0	10.5	S25 11.3	2.4	54.3	36	□	□	□	□	□	□	□	□	□	□	
19	105 42.0	28.3	282 36.5	10.4	25 13.7	2.3	54.3	34	□	□	□	□	□	□	□	□	□	□	
20	120 41.9	28.7	297 05.9	10.4	25 16.0	2.1	54.3	32	□	□	□	□	□	□	□	□	□	□	
21	135 41.8	29.1	311 35.3	10.5	25 18.1	2.1	54.3	30	□	□	□	□	□	□	□	□	□	□	
22	150 41.7	29.5	326 04.8	10.4	25 20.2	1.9	54.3	28	□	□	□	□	□	□	□	□	□	□	
23	165 41.7	29.9	340 34.2	10.4	25 22.1	1.8	54.3	26	□	□	□	□	□	□	□	□	□	□	
29 00	180 41.6	N21 30.3	355 03.6	10.4	S25 23.9	1.7	54.2	S 50	□	□	□	□	□	□	□	□	□	□	
01	195 41.5	30.7	9 33.0	10.4	25 25.6	1.5	54.2	52	□	□	□	□	□	□	□	□	□	□	
02	210 41.4	31.1	24 02.4	10.5	25 27.1	1.5	54.2	54	□	□	□	□	□	□	□	□	□	□	
03	225 41.3	31.5	38 31.9	10.4	25 28.6	1.3	54.2	56	□	□	□	□	□	□	□	□	□	□	
04	240 41.3	31.9	53 01.3	10.4	25 29.9	1.2	54.2	58	□	□	□	□	□	□	□	□	□	□	
05	255 41.2	32.3	67 30.7	10.4	25 31.1	1.0	54.2	S 60	□	□	□	□	□	□	□	□	□	□	
06	270 41.1	N21 32.7	82 00.1	10.4	S25 32.1	0.9	54.2	62	□	□	□	□	□	□	□	□	□	□	
07	285 41.0	33.1	96 29.5	10.4	25 33.0	0.9	54.2	64	□	□	□	□	□	□	□	□	□	□	
W 08	300 41.0	33.5	110 58.9	10.4	25 33.9	0.8	54.2	66	□	□	□	□	□	□	□	□	□	□	
D 09	315 40.9	33.9	125 28.3	10.4	25 34.5	0.8	54.2	68	□	□	□	□	□	□	□	□	□	□	
E 10	330 40.8	34.3	139 57.7	10.4	25 35.1	0.4	54.2	70	□	□	□	□	□	□	□	□	□	□	
S 11	345 40.7	34.7	154 27.1	10.4	25 35.5	0.3	54.2	N 72	□	□	□	□	□	□	□	□	□	□	
D 12	0 40.6	N21 35.1	168 56.5	10.5	S25 35.8	0.2	54.2	74	□	□	□	□	□	□	□	□	□	□	
A 13	15 40.6	35.5	183 26.0	10.6	25 36.0	0.1	54.2	76	□	□	□	□	□	□	□	□	□	□	
Y 14	30 40.5	35.9	197 55.4	10.4	25 36.1	0.1	54.1	78	□	□	□	□	□	□	□	□	□	□	
15	45 40.4	36.2	212 24.8	10.5	25 36.0	0.2	54.1	80	□	□	□	□	□	□	□	□	□	□	
16	60 40.3	36.6	226 54.3	10.5	25 35.8	0.3	54.1	82	□	□	□	□	□	□	□	□	□	□	
17	75 40.2	37.0	241 23.8	10.4	25 35.5	0.4	54.1	84	□	□	□	□	□	□	□	□	□	□	
18	90 40.2	N21 37.4	255 53.2	10.5	S25 35.1	0.6	54.1	N 58	□	□	□	□	□	□	□	□	□	□	
19	105 40.1	37.8	270 22.7	10.5	25 34.5	0.6	54.1	60	□	□	□	□	□	□	□	□	□	□	
29 00	120 38.4	45.4	200 18.8	11.0	24 51.2	3.2	54.0	S 58	□	□	□	□	□	□	□	□	□	□	
01	135 38.3	45.8	214 46.6	11.0	24 54.7	3.2	54.0	60	□	□	□	□	□	□	□	□	□	□	
02	150 38.2	46.1	229 16.6	11.0	24 51.5	3.3	54.0	S 60	□	□	□	□	□	□	□	□	□	□	
03	165 38.2	46.5	243 46.6	11.1	S24 48.2	3.4	54.0	62	□	□	□	□	□	□	□	□	□	□	
04	180 38.1	46.9	258 16.7	11.1	24 4														

# How to Determine the Time of Sunrise, Sunset, Moonrise, Moonset, and Twilight

## Strip Forms and the Navigation Workbook

OPNAV Navigation Strip Forms have evolved from a need to have a standard method of working celestial problems. The strip forms are located in the back of the Navigation Workbook (OPNAV 3530/1) and they are designed to work with the individual pages of the Navigation Workbook. Every time a celestial observation is taken that fixes the ship's position, you must keep a record of the results in the Navigation Workbook.

## How to Determine the Time of Sunrise

We will learn how to determine the time of sunrise by using a practical example. Use the table on the next page and figure 6-4 to work the strip form.

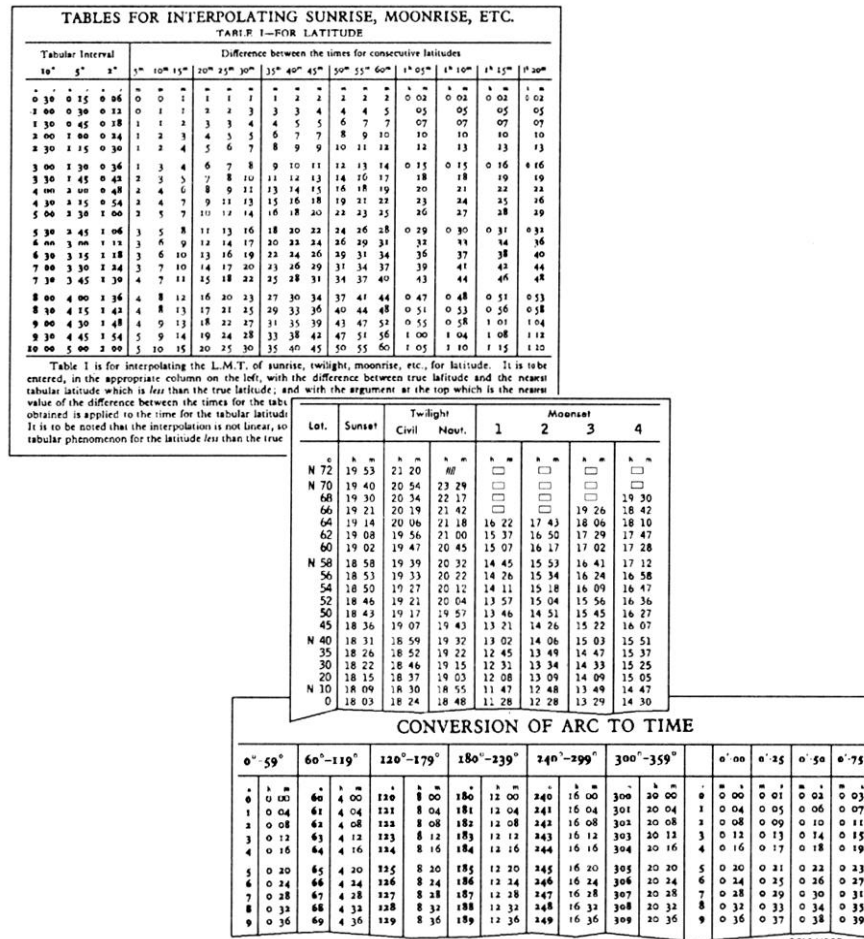

Figure 6-4. Excerpt from *The Nautical Almanac*.

## How to Determine the Time of Sunrise, and Sunset..., Continued

### Example

In our example, we will assume that at 1500 on 1 Sep 94 our training ship is located at 36° 14.0' N 069° 26' W, on course 090° T at a speed of 10 knots. Problem: find the time of sunset.

OPNAV 3530/38 (4-73) SUNSET/RISE	Step	Action	Completed Strip Form
DR Lat	1.	From <i>the Nautical Almanac</i> note the time of tab sunset for the latitude closest to your current position.	DR Lat 36° 14'N
Tab Interval	2.	Enter the interval between the two latitudes closest to your DR Lat.	Tab Interval 5°
Lat Interval	3.	Enter the time difference between the two latitudes.	Lat Interval 5 min
Lat Diff	4.	Enter the difference between your DR Lat. and the <i>lower tab latitude</i> .	Lat Diff 1°14'
Corr Table I	5.	Go to Correction Table I in the Nautical Alm., follow the instructions at the bottom of the table to determine the time correction.	Corr Table I 1 min
Tab LMT	6.	Enter the time of the tabulated lat., use the tab lat that is lower than your DR Lat.	Tab LMT 1826
Corr LMT	7.	Add the time correction.	Corr LMT 1827
DRλ	8.	Enter the DR Longitude.	DRλ 069° 26'
STD Mer	9.	Enter the value for the time zone that the ship is keeping, in this case +5R express in degrees, 5 x 15 = 75.	STD Mer 075°
dλ(arc)	10.	Find the lat difference between 75° and DRλ 069°26'.	dλ (arc) 5° 34'

## How to Determine the Time of Sunrise, and Sunset,..., Continued

dλ(time)	11.	Enter the Arc to Time Conversion table on the left column, finding the time value for 5° (20m) and then enter the right column for 34' (2m 16s) and add the values together for the total time correction.	dλ(time) 22m 16s  Round off to closest minute.						
LMT	12.	LMT = Corr LMT + or - dλ(time) <table border="1" data-bbox="565 653 1008 894"> <thead> <tr> <th>IF...</th> <th>THEN...</th> </tr> </thead> <tbody> <tr> <td>DRλ is less than STD Mer</td> <td>Subtract dλ (time) from Corr LMT</td> </tr> <tr> <td>DRλ is greater than STD Mer</td> <td>Add dλ (time) to Corr LMT</td> </tr> </tbody> </table>	IF...	THEN...	DRλ is less than STD Mer	Subtract dλ (time) from Corr LMT	DRλ is greater than STD Mer	Add dλ (time) to Corr LMT	Corr LMT 1827 dλ(time) <u>-22</u> LMT = 1802
IF...	THEN...								
DRλ is less than STD Mer	Subtract dλ (time) from Corr LMT								
DRλ is greater than STD Mer	Add dλ (time) to Corr LMT								

### How to Determine the Time of Twilight

To find the time of twilight, use the same steps you use to find the time of sunrise or sunset except use the tab values from the twilight column. It is helpful in some operations to know the exact time of twilight.

### Finding the Time of Moonrise or Moonset

Use strip form 3530/39 to find the time of moonrise or moonset. The procedure is exactly the same as the one used to find the time of SR or SS except that an additional correction must be made from table II of the *Nautical Almanac*. A correction for the time difference between tab LMT and the preceding or following day must be applied from table II. Simple instructions for this correction can be found at the bottom of table II.

## How to Determine Star Time and Selected Stars Using Pub 249 Vol I (Selected Stars)

---

### Example

Determining star time and selected stars for morning or evening observations is simple. The process involves finding the time of sunrise for morning observation or sunset for evening observations. Then you find the LHA of Aries for the time of star time and record the data for the seven stars on a worksheet.

**Rule:** Add 30 minutes to the time of sunset to determine evening star time, subtract 45 minutes from sunrise to determine morning star time.

**Example:** The ship is located at 36°14.0' N 069°14' W, the date is 01 Sep 91. The ship is on course 090°T and is keeping +5R time zone.

---

### Discussion

Although there are other methods of determining which navigational stars are available for observations, using Pub 249 is the most widely used method. In step 10, you are directed to record the values for Hc (height computed) and Zn (the azimuth angle, or the true direction to point the sextant towards) on a worksheet. At the time of publication, there is NOT a standard worksheet available for use. A recommended format is supplied on page 11. Use a PC word processor to reproduce this worksheet locally.

Use figure 6-5 on the following page along with the example OPNAV form to find selected stars.



172 1991 SEPTEMBER 1, 2, 3 (SUN., MON., TUE)

LIT (GMT)	ARIES			VENUS -4.2			MARS +1.8			JUPITER -1.7			SATURN +0.3		
	G.H.A.	G.H.A.	Dec.	G.H.A.	Dec.	G.H.A.	Dec.	G.H.A.	Dec.	G.H.A.	Dec.	G.H.A.	Dec.		
00	339 39.7	196 04.6	N 5 41.6	159 32.5	N 0 43.3	189 36.7	N 13 02.9	36 12.0	S 20 25.1						
01	354 42.1	211 08.2	42.1	174 33.5	42.6	204 38.7	02.7	51 14.6	25.1						
02	9 44.6	226 11.7	42.7	189 34.5	42.0	219 40.6	02.5	66 17.2	25.1						
03	24 47.1	241 15.2	43.2	204 35.5	41.3	234 42.5	02.3	81 19.8	25.2						
04	39 49.5	256 18.7	43.7	219 36.5	40.7	249 44.5	02.1	96 22.4	25.2						
05	54 52.0	271 22.2	44.2	234 37.5	40.0	264 46.4	01.9	111 25.0	25.2						
06	69 54.5	286 25.7	N 5 44.7	249 38.5	N 0 39.3	279 48.4	N 13 01.7	126 27.6	S 20 25.3						
07	84 56.9	301 29.2	45.2	264 39.5	38.7	294 50.3	01.6	141 30.2	25.3						
08	99 59.4	316 32.7	45.7	279 40.5	38.0	309 52.2	01.4	156 32.8	25.3						
09	115 01.9	331 36.2	46.3	294 41.5	37.4	324 54.2	01.2	171 35.4	25.4						
10	130 04.3	346 39.7	46.8	309 42.5	36.7	339 56.1	01.0	186 38.0	25.4						
11	145 06.8	1 43.2	47.3	324 43.5	36.0	354 58.1	00.8	201 40.6	25.4						
12	160 09.2	16 46.7	N 5 47.8	339 44.5	N 0 35.4	10 00.0	N 13 00.6	216 43.2	S 20 25.4						
13	175 11.7	31 50.2	48.3	354 45.5	34.7	25 01.9	00.5	231 45.8	25.5						
14	190 14.2	46 53.7	48.8	9 46.5	34.1	40 03.9	00.3	246 48.4	25.5						
15	205 16.6	61 57.1	49.4	24 47.5	33.4	55 05.8	13 00.1	261 51.0	25.5						
16	220 19.1	77 00.6	49.9	39 48.5	32.7	70 07.8	12 59.9	276 53.6	25.6						
17	235 21.6	92 04.1	50.4	54 49.5	32.1	85 09.7	59.7	291 56.2	25.6						
18	250 24.0	107 07.5	N 5 50.9	69 50.5	N 0 31.4	100 11.7	N 12 59.5	306 58.8	S 20 25.6						
19	265 26.5	122 11.0	51.4	84 51.5	30.8	115 13.6	59.4	322 01.4	25.7						
20	280 29.0	137 14.4	51.9	99 52.5	30.1	130 15.5	59.2	337 03.9	25.7						
21	295 31.4	152 17.9	52.5	114 53.5	29.4	145 17.5	59.0	352 06.5	25.7						
22	310 33.9	167 21.3	53.0	129 54.4	28.8	160 19.4	58.8	7 09.1	25.7						
23	325 36.4	182 24.8	53.5	144 55.4	28.1	175 21.4	58.6	22 11.7	25.8						

LIT (GMT)	ARIES			VENUS -4.2			MARS +1.8			JUPITER -1.7			SATURN +0.3		
	G.H.A.	G.H.A.	Dec.	G.H.A.	Dec.	G.H.A.	Dec.	G.H.A.	Dec.	G.H.A.	Dec.	G.H.A.	Dec.		
200	340 38.8	197 28.2	N 5 54.0	159											
01	355 41.3	212 31.7	54.5	174											
02	10 43.7	227 35.1	55.0	189											
03	25 46.2	242 38.5	55.6	204											
04	40 48.7	257 42.0	56.1	221											
05	55 51.1	272 45.4	56.6	236											
06	70 53.6	287 48.8	N 5 57.1	251											
07	85 56.1	302 52.2	57.6	266											
08	100 58.5	317 55.6	58.1	281											
M 09	116 01.0	332 59.0	58.7	296											
O 10	131 03.5	348 02.5	59.2	311											
N 11	146 05.9	3 05.9	5 59.7	326											

CORRECTIONS									
II	SUN PLANETS	ARIES	MOON	° of Corr <sup>d</sup>	° of Corr <sup>d</sup>	° of Corr <sup>d</sup>			
00	2 45-0	2 45-5	2 37-5	0-0	0-0	6-0 1-2			
01	2 45-3	2 45-7	2 37-7	0-1	0-0	6-1 1-2			
02	2 45-5	2 46-0	2 38-0	0-2	0-0	6-2 1-2			
03	2 45-8	2 46-2	2 38-2	0-3	0-1	6-3 1-2			
04	2 46-0	2 46-5	2 38-4	0-4	0-1	6-4 1-2			
05	2 46-3	2 46-7	2 38-7	0-5	0-1	6-5 1-2			
06	2 46-5	2 47-0	2 38-9	0-6	0-1	6-6 1-3			
07	2 46-8	2 47-2	2 39-2	0-7	0-1	6-7 1-3			
08	2 47-0	2 47-5	2 39-4	0-8	0-2	6-8 1-3			
09	2 47-3	2 47-7	2 39-6	0-9	0-2	6-9 1-3			
10	2 47-5	2 48-0	2 39-9	1-0	0-2	7-0 1-3			
11	2 47-8	2 48-2	2 40-1	1-1	0-2	7-1 1-4			
12	2 48-0	2 48-5	2 40-3	1-2	0-2	7-2 1-4			
13	2 48-3	2 48-7	2 40-6	1-3	0-2	7-3 1-4			
14	2 48-5	2 49-0	2 40-8	1-4	0-3	7-4 1-4			
15	2 48-8	2 49-2	2 41-1	1-5	0-3	7-5 1-4			
16	2 49-0	2 49-5	2 41-3	1-6	0-3	7-6 1-5			
17	2 49-3	2 49-7	2 41-5	1-7	0-3	7-7 1-5			
18	2 49-5	2 50-0	2 41-8	1-8	0-3	7-8 1-5			
19	2 49-8	2 50-2	2 42-0	1-9	0-4	7-9 1-5			
20	2 50-0	2 50-5	2 42-3	2-0	0-4	8-0 1-5			
21	2 50-3	2 50-7	2 42-5	2-1	0-4	8-1 1-6			
22	2 50-5	2 51-0	2 42-7	2-2	0-4	8-2 1-6			
23	2 50-8	2 51-2	2 43-0	2-3	0-4	8-3 1-6			
24	2 51-0	2 51-5	2 43-2	2-4	0-5	8-4 1-6			
25	2 51-3	2 51-7	2 43-4	2-5	0-5	8-5 1-6			
26	2 51-5	2 52-0	2 43-7	2-6	0-5	8-6 1-6			
27	2 51-8	2 52-2	2 43-9	2-7	0-5	8-7 1-7			
28	2 52-0	2 52-5	2 44-2	2-8	0-5	8-8 1-7			
29	2 52-3	2 52-7	2 44-4	2-9	0-6	8-9 1-7			

26NVJ066

Figure 6-5. Excerpts from *The Nautical Almanac*.

## How to Determine Star Time and Selected Stars Using Pub 249 Vol I (Selected Stars), Continued

Step	Action	Result
1.	Determine the time of sunset.	1841
2.	Add 30 minutes to the time of sunset (star time). Find and note the DR position for 1911. For our example we will use 36°14.0'N 069°04'W.	1911
3.	Find GMT of star time 1911. Remember to find GMT apply the ZD to LMT.	00h 11m 02 Sep 91
4.	From the left-hand pages of the <i>Nautical Almanac</i> , find the GHA of Aries.	339°39'.7
5.	From the Increments and Corrections pages find the page with 11 <sup>m</sup> and then find the value for Aries for 00 seconds.	2° 45'.5
6.	Find the total GHA of Aries by adding the results from step 4 and 5 together. Remember to carry over 1 whole degree whenever the total minutes are greater than 60. Ex. 85 - 60 = 25 carry 1°.	339°39'.7 + 2° 45'.5 342°25'.2
7.	Find the LHA of Aries by subtracting west longitude, or adding east longitude.	342°25'.2 -069°04'.5 273°21'.2
8.	Round off DR lat. and LHA Aries to the closest °.	DR lat. = 36° N LHA Aries 273°
9.	Enter Pub 249 on the page for 36° N.	
10.	Record the values for Hc and Zn for each star for LHA Aries for 273° on a worksheet.	See example worksheet on next page.

## Pub 249 Selected Stars Worksheet

Find the LHA of Aries for star time, use Pub 249 for closest latitude and LHA Aries, record the results.

Name of Star	Hc	Zn	Observed Hc	Observed Zn	GMT of Observation
DENEb	60 30	060			
ALTAIR	54 48	134			
NUNKI	26 53	169			
ANTARES	23 02	205			
ARCTURUS	35 49	269			
ALKAID	41 13	308			
KOCHAB	44 56	343			

Map the Zn of each selected star as it relates to the ship's head just prior to taking sights (celestial observations).

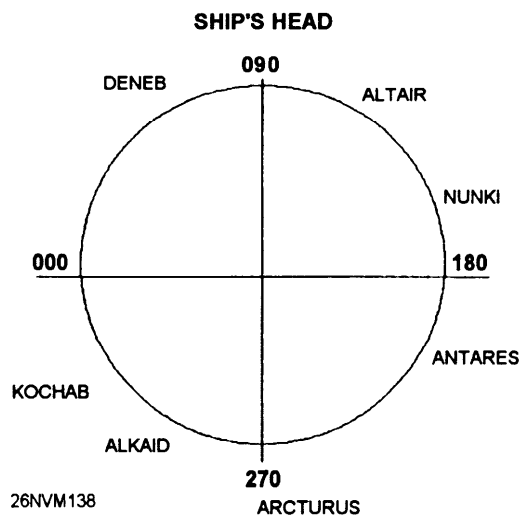

# How to Determine Selected Stars using The *Rude Starfinder*

## Components

*The Rude Starfinder* is made up of a plastic star base showing stars of the northern hemisphere on one side, and stars of the southern hemisphere on the other side, and 10 transparent templates. Nine templates printed in blue, with each template covering 10° of latitude, labeled 5°, 15°, 25°, and so on, plus a tenth template printed in red showing meridian angle and declination for use in the plotting of planets. Each latitude template has a family of altitude curves at 5° intervals from the horizon to 80°. From these curves, you can determine the height of a star or planet. A second family of curves, also at 5° intervals, indicate the azimuth (true bearing) of a star or planet. The north-south azimuth line represents the celestial meridian. The star base, templates, and a set of instructions are housed in a leatherette case.

## Uses

The starfinder has four purposes: to identify an unknown star, to select several stars for observation, to plot planets for observation, and identify a star's magnitude. For example, when taking sights for evening stars, you shoot a star or planet that is not part of your selected stars list obtained from Pub 249. You can identify the celestial body using the starfinder. This proves to be extremely useful when overcast weather conditions exists.

## Using the Starfinder

Follow the steps in the table to create a list of selected stars for observation. Refer to the instructions that are included with the star finder to identify an unknown body.

Step	Action
1.	Find the LHA of Aries for star time, follow steps 1 through 7 on pages 6-12.
2.	Place the template for the latitude closest to the DR latitude on the star base.
3.	Move the pointer to the correct LHA.
4.	Select eight stars that provide 360° of coverage at intervals of about 20°.
5.	Record the height and azimuth of each star. It will be helpful to list stars in the order of increasing azimuth.  <b>Example:</b> Vega 019° T, Arcturus 043° T, and so on.

# Chapter 7

## Tides and Currents

---

### Introduction

The ability to determine the height of a tide or velocity of a current is necessary for the safe navigation of any vessel. There are many methods of determining this data. The Quartermaster uses the Tide Tables and Tidal Current Tables that you were introduced to in Chapter 4. In this chapter, you will learn the actual mechanics of determining tide heights and current velocities.

---

### Objectives

The material in this chapter will enable the student to:

- Define the following terms associated with the rising and falling tide phenomena:
  - a. High tide or high water; low tide or low water
  - b. Range of tide and the duration of rise and fall
  - c. Stand
- Define the terms *spring tide* and *neap tide*.
- Match the three types of tides listed below with their characteristics:
  - a. Semidiurnal
  - b. Diurnal
  - c. Mixed
- Match the following terms associated with tidal reference planes with their definitions:
  - a. Charted depth
  - b. Mean high water (MHW)
  - c. Mean low water (MLW)
  - d. Mean lower low water (MLLW)
  - e. Mean range of tide
- Extract the following information from tables 1 through 3 of the Tide Tables:
  - a. Reference station
  - b. Subordinate station time and height differences
  - c. Correction factor for height at any time

## Objectives, Continued

- 
- Calculate the height of tide at any time for any station listed in the Tide Tables.
  - Plot tidal information on a tide graph.
  - Match the following terms with their meanings:
    - a. Tidal and nontidal currents
    - b. Flood and ebb
    - c. Slack water
    - d. Duration of flood and ebb
    - e. Set and speed of current
    - f. Rotary current
  - Identify the general features of tidal currents.
  - Calculate the times of minimum and maximum current and slack water at a given location, as well as the average direction of the current.
  - Calculate the speed of the current at any time for any location.
- 

<b>Topic</b>	<b>Page</b>
Effect of the Sun and Moon on Tides	7-4
Types of Tides and Reference Planes	7-5
Tide Tables	7-6
How to Determine the Height of Tide	7-7
How to Graph Tide Data	7-12
Tidal Currents	7-16
Tidal Current Tables	7-18
Current Calculations	7-19
How to Graph Tidal Currents	7-23

# Introduction to Tides

---

## Background Information

Whenever your ship enters or leaves port, one of your most important tasks will be to calculate how much water will be available along your route of transit. The importance of accurate tide calculations cannot be overemphasized. If your ship attempts to pass beneath a bridge without adequate vertical clearance, you could lose the ship's mast. If you pass over a shoal with an insufficient depth of water, your ship will probably go aground, losing sonar dome, rudder, and propellers. All navigational charts reference the depth soundings in mean low water.

---

## Definition

**Tide** is the vertical rise and fall of the ocean level caused by the gravitational forces between Earth and the Moon, and Earth and the Sun. Generally speaking, these interacting forces between the planets cause the tides to rise and fall twice daily, this is known as a tidal day. The period of one high and one low is referred to as a tidal cycle.

---

## Terms Associated with Tides

Use the following table to learn the meanings of terms that are associated with tides.

Term	Definition
High tide or high water (HW)	The maximum height of the water resulting from the rising tide.
Low tide or low water (LW)	The minimum height of the water resulting from the outgoing tide.
Duration of rise and fall	The period of time measured in hours and minutes that it takes the tide to go from low water to high water.
Range of tide	The distance between HW and LW.
Stand	A brief period where no rise or fall occurs; this occurs when the tide reaches its maximum or minimum level.
Mean high water (MHW)	The average height of all high-tide water levels, measured over a 19-year period.
Mean low water (MLW)	The average height of all low-tide levels, observed over a 19-year period.
Mean lower low water (MLLW)	The average of the lower of the low water levels, observed over a period of 19-years. This is the reference plane currently used on almost all charts covering U.S. waters as the basis of measurement of charted depths and height of tide.

# Effect of the Sun and Moon on Tides

## Spring and Neap Tides

As previously mentioned, tides that occur on Earth result from both solar and lunar influences. When these two bodies are in line with Earth, as shown in figure 7-1, their combined effect causes high tides to be higher than average and low tides to be lower than average. These types of tides are referred to as spring tides (and has nothing to do with the season of the year).

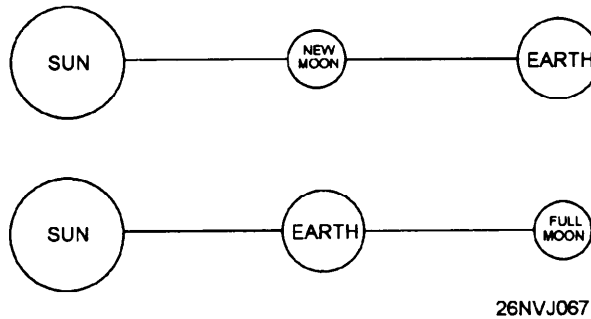

Figure 7-1. Spring tides occur when influences of the Sun and the Moon act together.

When the direction of the Sun and the Moon are  $90^\circ$  apart, as when the Moon is in the first and last quarter, the gravitational effect of the Sun counteracts that of the Moon enough that both high and low tides are lower than normal. These types of tides are referred to as neap tides.

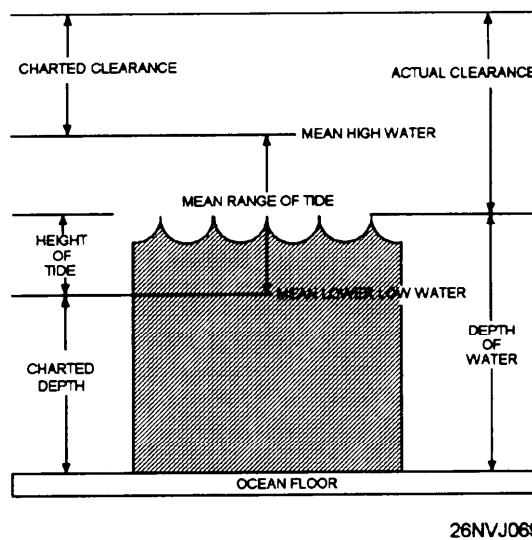

Figure 7-2. Relationship of terms used when measuring heights and depths.



# Types of Tides and Reference Planes

---

## Semidiurnal, Diurnal, and Mixed Tides

According to the characteristics of the tidal pattern occurring at a particular place, tides are classified as semidiurnal, diurnal, or mixed.

In **semidiurnal tides**, there are two high and two low tides each tidal day, and they occur at fairly regular intervals. Usually, there are only relatively small variations in the height of any two successive high or low waters. Tides on the Atlantic coast of the United States are representative of this pattern.

In **diurnal tides**, there is only one high and one low tide each tidal day. The water levels on succeeding days usually do not vary a great deal. In the United States, diurnal tides occur along the northern shore of the Gulf of Mexico.

In **mixed tides**, the tidal pattern is characterized by wide variations in heights of successive high and low waters. There are usually two high and two low waters each day, but occasionally the tide may become diurnal. In the United States, mixed tides occur along the Pacific Coast, Alaska, and Hawaii. If information for water depths, heights, elevations of topographical features, aids to navigation, bridge clearances, and so forth are to be meaningful when printed on nautical charts, standard reference planes for their measurements must be used. For this reason, standard reference planes for these measurements have been established.

Generally speaking, heights and elevations are given on a chart in reference to a standard high-water plane, while heights of tide and charted depths of water are given with respect to a standard low-water plane (see fig. 7-2). The **charted depth** is simply the vertical distance from the low-water reference plane to the ocean bottom; it's the depth figure you see printed on nautical charts. The charted height is the vertical distance above the water measured from the high-water reference plane.

The **mean range of tide** is the vertical distance between the high water and low-water reference planes used, and represents the **average range of tide** at a given location. You should remember that the water level will sometimes be below the reference plane. Put another way, sometimes the actual **depth of water** can be less than the **charted depth**. You will recognize this situation because there will be a minus sign (-) placed before the height of tide shown in the Tide Tables. In this case, you subtract the value of the **height of tide** from the **charted depth** to find the **actual depth of water**.

# Tide Tables

---

## Layout

Tide Tables are published annually by the National Oceanic and Atmospheric Administration. They are published in four volumes: Europe and West Coast of Africa (including the Mediterranean Sea); East Coast of North and South America (including Greenland); West Coast of North and South America (including the Hawaiian Islands); Central and Western Pacific Ocean and Indian Ocean.

The Tide Tables contain seven tables; each are briefly explained below:

Table 1 contains the predicted times and heights of high and low waters for each day of the year at a number of places called reference stations. All times stated in this table are for standard time. When using daylight savings time, you must remember to add 1 hour.

Table 2 contains tidal difference information for heights and times at a number of places called subordinate stations. This information is listed in geographical order; each subordinate station is given a number, its location is described, and its position is given to the nearest minute. The data given for the subordinate station are applied to the predictions at a specified reference station to obtain the tidal information for the subordinate station. You'll see how this works in the example problems that follow.

Table 3 contains information used for finding the approximate height of the tide at any time between high and low water. This table also contains instructions for plotting tide information using a graphical method. The graphical method is handy for those occasions when the height of tide is required for a number of times on a given day.

Table 4 is a sunrise-sunset table listing LMT of the Sun's upper limb for every 5th day of the year.

Table 5 provides an adjustment to convert the LMT found in table 4 to zone or standard time.

Table 6 gives the zone time of moonrise and moonset for each day of the year at certain places.

Table 7 is a conversion of feet to meters table.

# How to Determine the Height of Tide

## Procedure

Finding the **height of the tide** is relatively simple. In the following example, we will calculate the height of tide at the George Washington Bridge on the Hudson River, NY. The time desired is 1100 standard time, 8 September 1993. To make our job easier, we will use OPNAV strip form 3530/40 *HT OF TIDE*.

OPNAV 3530/40 (4-73) HT OF TIDE	Step	Action	Completed Strip Form
Date	1.	Enter the desired date.	08 SEPT
Location	2.	Enter the location. Find George Washington Bridge in the alphabetical index in the back of the Tide Tables. The subordinate station number is found to be #1561 in table 2.	George Washington Bridge
Time	3.	Enter the desired time.	1100
Ref Station	4.	<p>The reference station is found by first finding our subordinate station (George Washington Bridge) #1561 in table 2, and then looking in the center of the DIFFERENCE column and following it upward (as shown in fig. 7-4) to the line entitled "on New York p. 56."</p> <p>Figure 7-3 is an excerpt from table 2. The data for steps 5, 6, 7, and 8 are found by inspecting the times and heights differences for 8 Sep for the George Washington Bridge.</p>	New York

# How to Determine the Height of Tide, Continued

OPNAV 3530/40 (4-73) HT OF TIDE	<b>Step</b>	<b>Action</b>	Completed Strip Form
HW Time Diff	5.	Under the DIFFERENCES column find the value for high-water time.	+0 50
LW Time Diff	6.	Under the DIFFERENCES column find the value for low-water time.	+0 46
HW Ht Diff	7.	Under the DIFFERENCES column find the value for high-water height.	*0.84
LW Ht Diff	8.	Under the DIFFERENCES column find the value for low-water height.	*0.85

**TABLE 2 – TIDAL DIFFERENCES AND OTHER CONSTANTS**

No.	PLACE	POSITION		DIFFERENCES				RANGES		Mean Tide Level
		Latitude	Longitude	Time		Height		Mean	Spring	
				High Water	Low Water	High Water	Low Water			
		North	West	h m	h m	ft	ft	ft	ft	
	<b>NEW YORK and NEW JERSEY</b> New York Harbor									
				on New York, p.56						
1535	Bay Ridge	40° 38'	74° 02'	-0 20	-0 21	*1.01	*1.00	4.6	5.5	2.5
1537	St. George, Staten Island	40° 39'	74° 04'	-0 17	-0 15	*0.99	*0.99	4.5	5.4	2.4
1539	Bayonne, N.J.	40° 41'	74° 06'	-0 15	-0 05	*0.99	*0.99	4.5	5.4	2.4
1541	Gowanus Bay	40° 40'	74° 01'	-0 18	-0 12	*1.03	*0.95	4.7	5.7	2.6
1543	Governors Island	40° 42'	74° 01'	-0 07	-0 03	*0.96	*0.95	4.4	5.3	2.4
1545	NEW YORK (The Battery)	40° 42'	74° 01'					4.6	5.5	2.5
	Hudson River <8>									
1547	Jersey City, Con Rail RR, Ferry, N.J.	40° 43'	74° 02'	+0 11	+0 10	*0.96	*0.96	4.4	5.3	2.4
1549	New York, Desbrosses Street	40° 43'	74° 01'	+0 14	+0 13	*0.96	*0.95	4.4	5.3	2.4
1551	New York, Chelsea Docks	40° 45'	74° 01'	+0 21	+0 19	*0.94	*0.95	4.3	5.2	2.3
1553	Hoboken, Castle Point, N.J.	40° 46'	74° 01'	+0 21	+0 19	*0.94	*0.94	4.3	5.2	2.3
1555	Weehawken, Days Point, N.J.	40° 46'	74° 01'	+0 28	+0 25	*0.92	*0.92	4.2	5.0	2.3
1557	New York, Union Stock Yards	40° 47'	74° 00'	+0 31	+0 29	*0.92	*0.92	4.2	5.0	2.3
1559	New York, 130th Street	40° 49'	73° 56'	+0 41	+0 38	*0.88	*0.88	4.0	4.8	2.2
1561	George Washington Bridge	40° 51'	73° 57'	+0 50	+0 46	*0.84	*0.85	3.9	4.6	2.1
1563	Spytten Duyvil, west of RR bridge	40° 53'	73° 56'	+1 02	+0 58	*0.83	*0.83	3.8	4.5	2.1
1565	Riverdale	40° 54'	73° 55'	+0 48	+0 49	*0.85	*0.91	3.9	4.7	2.1
1567	Yonkers	40° 58'	73° 54'	+1 13	+1 13	*0.81	*0.82	3.7	4.4	2.0
1569	Dobbs Ferry	41° 01'	73° 53'	+1 33	+1 43	*0.74	*0.73	3.4	4.0	1.9
1571	Tarrytown	41° 05'	73° 52'	+1 49	+1 57	*0.70	*0.70	3.2	3.7	1.8
1573	Ossining	41° 10'	73° 52'	+1 57	+2 17	*0.68	*0.68	3.1	3.6	1.8
1575	Haverstraw	41° 12'	73° 58'	+2 03	+2 28	*0.64	*0.64	2.9	3.4	1.6
1577	Peekskill	41° 17'	73° 56'	+2 28	+3 03	*0.64	*0.64	2.9	3.4	1.8
1579	West Point	41° 24'	73° 57'	+3 20	+3 40	*0.59	*0.59	2.7	3.1	1.7
1581	Newburgh	41° 30'	74° 00'	+3 46	+4 03	*0.62	*0.64	2.8	3.2	1.5
1583	New Hamburg	41° 35'	73° 57'	+4 04	+4 28	*0.64	*0.64	2.9	3.3	1.6
1585	Poughkeepsie	41° 42'	73° 57'	+4 34	+4 46	*0.66	*0.66	3.1	3.5	1.7
1587	Hyde Park	41° 47'	73° 57'	+5 00	+5 12	*0.70	*0.68	3.2	3.6	1.8
1589	Kingston Point	41° 56'	73° 58'	+5 20	+5 34	*0.81	*0.82	3.7	4.2	2.0
1591	Tivoli	42° 04'	73° 56'	+5 50	+6 04	*0.86	*0.86	3.9	4.4	1.9
1593	Catskill	42° 13'	73° 51'	+6 41	+6 58	*0.84	*0.91	4.1	4.6	1.9
1595	Hudson	42° 15'	73° 48'	+6 58	+7 12	*0.86	*0.86	4.0	4.4	2.2

26NVJ070

Figure 7-3. Excerpt from table 2 of the Tide Tables.

# How to Determine the Height of Tide, Continued

OPNAV 3530/40 (4-73) HT OF TIDE	<b>Step</b>	<b>Action</b>	<b>Completed Strip Form</b>								
Ref Sta HW/LW Time	9.	From the reference station (see fig. 7-4), enter the values for the HW and LW that 0700 falls between. See figure 7-3.	HW 1241/ LW 0536								
HW/LW Time Diff	10.	Write in the values from steps 5 and 6.	HW +50 / LW + 46								
Sub Sta HW/LW Time	11.	Apply time difference corrections.	<table style="width: 100%; border-collapse: collapse;"> <tr> <td style="text-align: center;">1241</td> <td style="text-align: center;">0536</td> </tr> <tr> <td style="text-align: center;">+ 50</td> <td style="text-align: center;">+ 46</td> </tr> <tr> <td style="text-align: center;">1331</td> <td style="text-align: center;">0622</td> </tr> <tr> <td style="text-align: center;">HW Time</td> <td style="text-align: center;">LW Time</td> </tr> </table>	1241	0536	+ 50	+ 46	1331	0622	HW Time	LW Time
1241	0536										
+ 50	+ 46										
1331	0622										
HW Time	LW Time										
Ref Sta HW/LW Ht	12.	From the reference station (table 1) enter the values for the HW and LW heights that correspond with step 9.	HW 4.7 / LW 1.2								
HW/LW Ht Diff	13.	Write in the values from steps 7 and 8.	HW *0.84 / LW *0.85								
Sub Sta HW/LW Ht	14.	Apply height difference corrections.	<table style="width: 100%; border-collapse: collapse;"> <tr> <td style="text-align: center;">4.7 * .84=3.9 HW Height</td> </tr> <tr> <td style="text-align: center;">1.2 * .85 =1.0 LW Height</td> </tr> </table>	4.7 * .84=3.9 HW Height	1.2 * .85 =1.0 LW Height						
4.7 * .84=3.9 HW Height											
1.2 * .85 =1.0 LW Height											

## New York (The Battery), N.Y., 1993

### Times and Heights of High and Low Waters

July				August				September																	
Time		Height		Time		Height		Time		Height		Time		Height											
h	m	ft	cm	h	m	ft	cm	h	m	ft	cm	h	m	ft	cm										
<b>8</b> Th	0507	0.3	9	<b>23</b> F	0458	-0.3	-9	<b>8</b> Su	0528	0.9	27	<b>23</b> M	0020	5.0	152	<b>8</b> W	0004	4.0	122	<b>23</b> Th	0201	4.4	134		
	1136	4.6	140		1125	5.5	168		1212	4.7	143		0617	0.3	9		0536	1.2	37		0815	1.0	30		
	1720	1.0	30		1724	0.3	9		1802	1.4	43		1252	5.7	174		1241	4.7	143		1428	5.1	155		
	2340	4.7	143	2341	5.4	165			1912	0.7	21			1916	1.5	46			2106	0.8	24				
<b>9</b> Fr	0545	0.6	18	<b>24</b> Sa	0648	-0.1	-3	<b>9</b> M	0007	4.2	128	<b>24</b> Tu	0116	4.7	143	<b>9</b> Th	0058	3.9	119	<b>24</b> F	0306	4.3	131		
	1218	4.6	140		1220	5.5	168		0552	1.1	34		0725	0.6	18		0631	1.4	43		0824	1.0	30		
	1805	1.3	40		1823	0.5	15		1250	4.6	140		1351	5.5	166		1333	4.7	143		1530	5.0	152		
								1858	1.5	48			2025	0.8	24			2047	1.4	43			2205	0.7	21
<b>10</b> Sa	0021	4.5	137	<b>25</b> Su	0036	5.1	155	<b>10</b> Tu	0045	4.1	125	<b>25</b> W	0217	4.4	134	<b>10</b> F	0159	3.9	119	<b>25</b> Sa	0409	4.4	134		
	0626	0.8	24		0642	0.2	6		0629	1.3	40		0837	0.6	24		0833	1.5	46		1024	0.9	27		
	1300	4.5	137		1313	5.5	168		1330	4.6	140		1451	5.3	162		1439	4.8	146		1630	4.9	149		
	1900	1.4	43	1934	0.7	21	1934	0.7	21	2021	1.6	49	2131	0.8	24	2148	1.2	37			2255	0.8	18		

Time meridian 75° W. 0000 is midnight. 1200 is noon.  
Heights are referred to mean lower low water which is the chart datum of soundings.

26NVJ071

Figure 7-4. Excerpt from Tide Table, table 1.

## How to Determine the Height of Tide, Continued

Now that we have the subordinate station data, we can complete the remainder of the problem; finding the height of the tide at the desired time of 0700.

OPNAV 3530/40 (4-73) HT OF TIDE	Step	Action	Completed Strip Form
Duration <b>Rise</b> <b>Fall</b>	15.	To compute this duration, find the two subordinate stations' times that bracket your desired time. In this case they are 0622 and 1331. Calculate the total time difference between the two ( $1331 - 0622 = 7$ hours 09 minutes). We can tell by observation that between 0622 and 1331 the tide is rising. Enter this data on the worksheet.	7h 09m rising
Time Fm <b>Near</b> <b>Tide</b>	16.	Next, determine the time nearest high/low for which the desired tide height is required. In this case the desired time of 1100 is nearest to high tide at 1331. Now find the time difference between the two ( $1331 - 1100 = 2$ h 31m). Enter this data on the worksheet.	2h 31m
Range of Tide	17.	Now calculate the range of tide. Simply find the difference between the height of high and low tide from the same two subordinate station times bracketed for duration above ( $3.9 - 1.0 = 2.9$ ). Enter this data on the worksheet.	2.9
Ht of Near Tide	18.	Enter the height of the nearest tide in this case from the high tide at 1331.	3.9 ft

## How to Determine the Height of Tide, Continued

OPNAV 3530/40 (4-73) HT OF TIDE	Step	Action	Strip Form
Corr Table III	19.	Enter the upper portion of the table with the nearest duration of rise or fall (upper left margin) for 7h 09m.	
	19 a.	Follow this line horizontally until you reach the column for the nearest value for the time to nearest high/low water (2 hour 3 1 minutes).	
	19 b.	Follow this column down to the lower half of the table until you intersect the nearest value for the range of tide (lower left margin). Extract the data (1.0 ft) and enter on the worksheet.	1.0 ft
HT of Tide	20.	<p>To find the final piece of information you need, height of tide, you must apply the correction as directed by the instructions at the bottom of table</p> <p>Those instructions are as follows:</p> <p><i>“When the nearest tide is high water, subtract the correction.”</i></p> <p><i>“When the nearest tide is low water, add the correction.”</i></p> <p>In this case the nearest tide is high, so you subtract the correction (3.9 -1.0 = 2.9 ft).</p>	2.9 ft

You have now computed the height of tide for 1100 standard time, September 8, 1993, at George Washington Bridge, N.Y. The tide will be 2.9 feet above mean lower low water (charted depth).

# How to Graph Tide Data

## Introduction

When the height of tide is required for a number of times on a certain day, the graphical method of determining tides can be very useful. For example, a buoy tender may spend an entire day servicing aids to navigation in one particular area. Having the tides displayed on a graph for the entire day will save you from having to calculate the height of tide separately for each aid you visit.

To illustrate how to construct a tide graph, we will use the same data presented in the previous section for the height of tide at Tue Marshes Light, Virginia. The form shown in figure 7-5 should prove helpful in guiding you through the problem, however, regular graph paper can be used if you desire.

# TIDES

DATE : 08 SEPTEMBER 94

REFERENCE STATION		DIFFERENCES				SUBORDINATE STATION	
LOCATION NEW YORK		TIME		HEIGHT		LOCATION GEORGE WASHINGTON BRIDGE	
	PAGE: 58	HIGH	LOW	HIGH	LOW	TIME	HEIGHT
	HEIGHT						
0004	4.0 FT	+50	+46	*0.84	*0.85	0054	3.4 FT
0536	1.2 FT					0622	1.0 FT
1241	4.7 FT					1331	3.9 FT
1916	1.5 FT					2002	1.3 FT

NOTE:  
1. \* = MULTIPLY  
2. MAKE CORR FOR DAYLIGHT SAVINGS TIME

26NVJ073

Figure 7-5. Sample tide graph form.



# How to Graph Tide Data, Continued

Step	Action
1.	Complete the upper section of the form by filling in the reference, subordinate, and differences data for 8 SEP 93. Notice on the graph that time is listed along the bottom in even hours (interpolate when necessary), and the height is listed along the left margin. The solid line at 0 feet is the base line, or charted depth.
2.	Set the height scale. Each line can represent one foot, one-half foot, one-tenth foot, and so on. Try to use a scale that results in the largest graphical representation practical. In our example, the largest increment we can use and still remain on the graph is 0.2 feet per line.
3.	Plot the high and low tide times and heights on the graph (fig. 7-6). Use the subordinate station data since you wish to know the tides at this location (Tue Marshes Light). Start with the first time and height listed, 0057 at 0.6 feet. Plot as shown below. Continue by plotting the other three points, then connect each point with a light line.

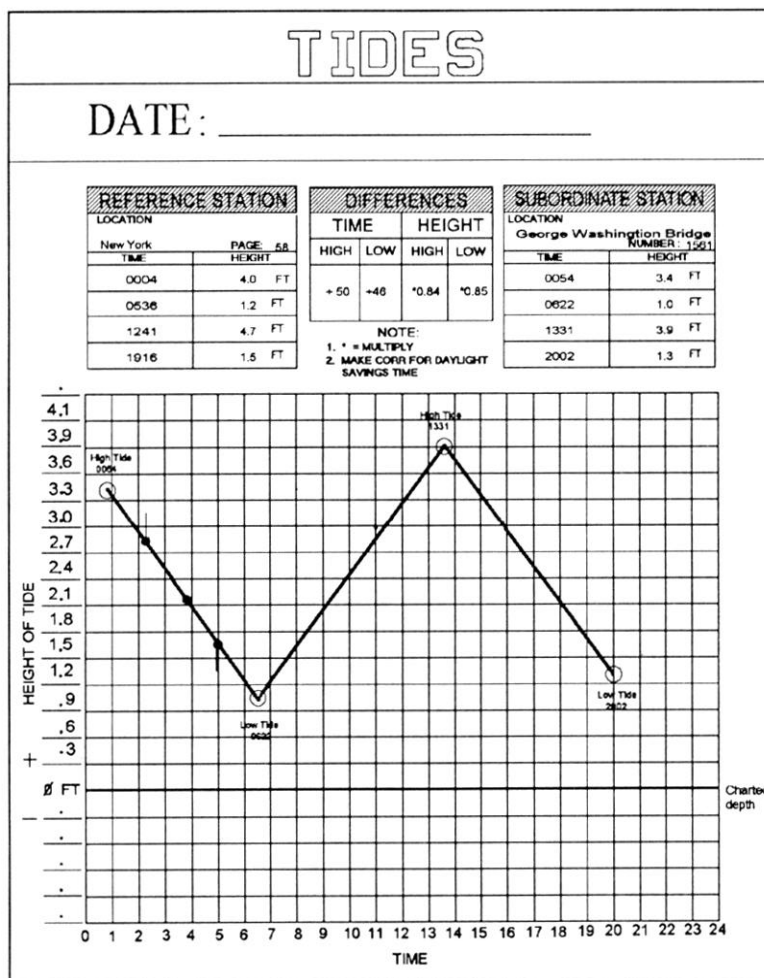

26NVJ074

Figure 7-6. Plot the times of high and low water on the graph.

# How to Graph Tide Data, Continued

Step	Action
4.	Divide the first line into four equal segments as shown in figure 7-6. The easiest way to do this is to extract the length of the line with dividers and place this length on the height scale. In the case of the first line, this distance is 2.0 feet (approximately). Divide this by 4 and you have the length of each segment $2.0/4 = 0.5$ feet. Measure 0.5 feet along the height scale with your dividers, then, starting at either end, divide the line into four segments.
5.	At the quarter point next to the high water point, draw a vertical line above the point; and at the quarter point next to low water point, draw a vertical line below the point equal to a distance of 1/10th of the total length of this line segment (i.e., $2.0 \times .1 = 0.2$ feet). Refer to the example
6.	Repeat steps 4 and 5 for the remaining two lines as shown in figure 7-7. Be sure to use the length of the line you are working with for your computations; using the same measurement for the first line will not work.

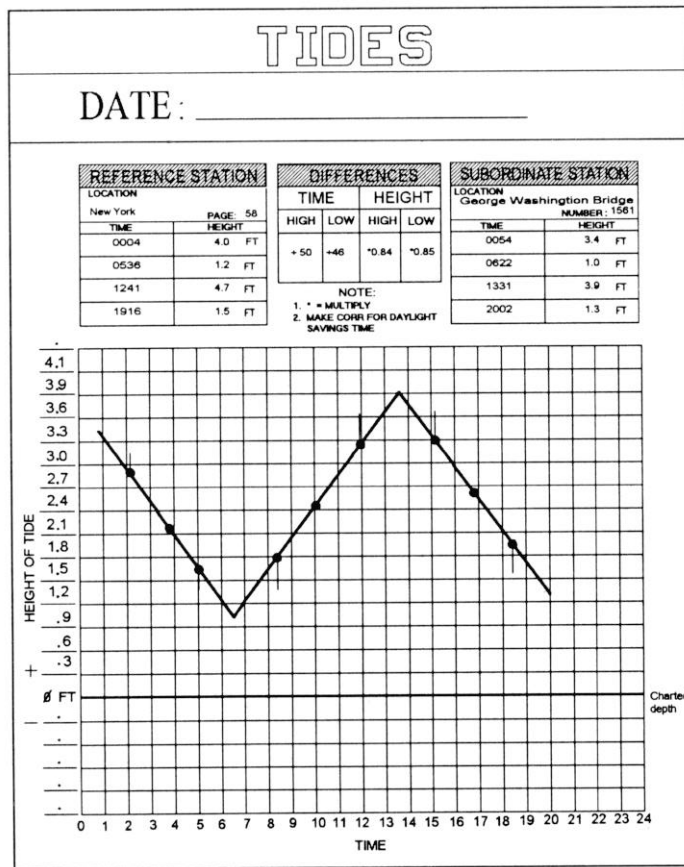

26NVJ075

Figure 7-7. Repeat steps for the remaining two lines.

# How to Graph Tide Data, Continued

Step	Action
7.	Draw a smooth curve through the points of high and low waters and the intermediate points, making the curve well rounded near the high and low waters as shown in figure 7-8. A french curve is helpful although freehand is fine.

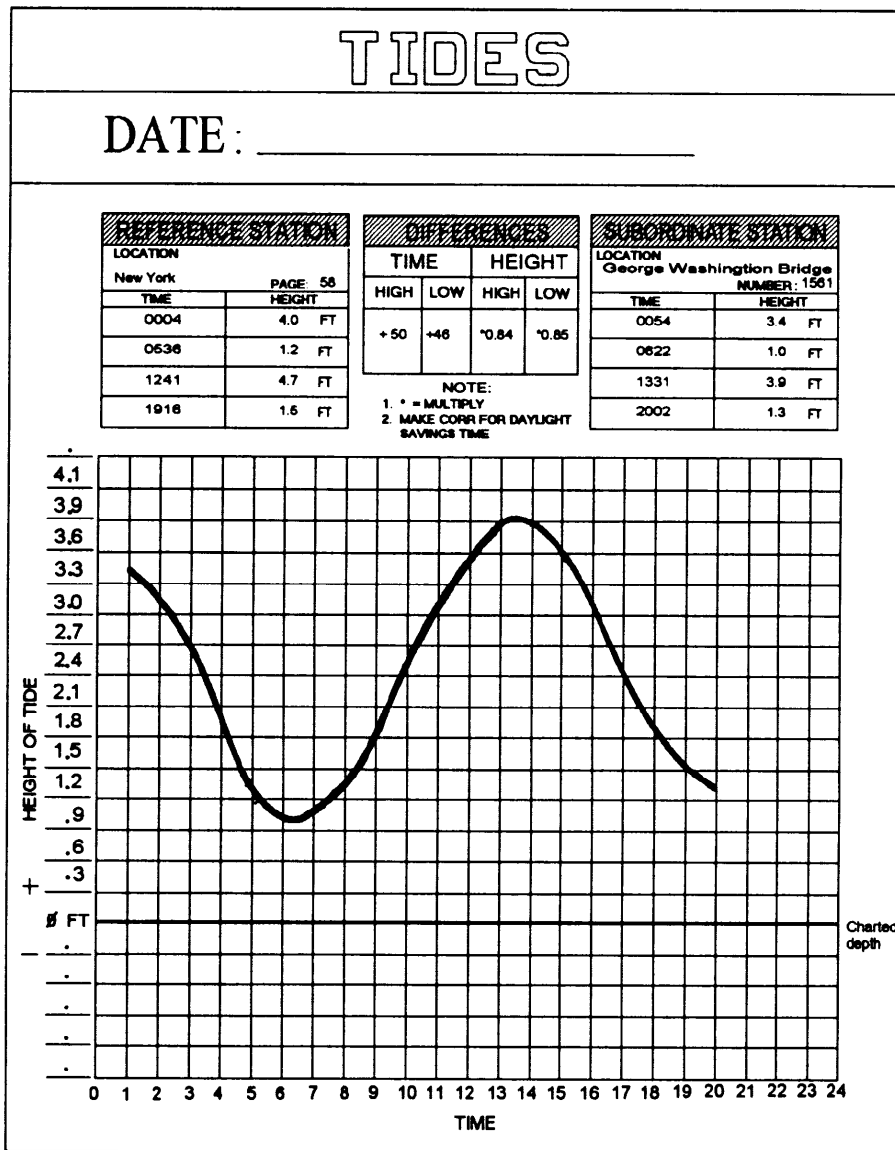

26NVJ076

Figure 7-8. Draw a smooth curve through the points.

# Tidal Currents

---

## Introduction

In navigation, the effect of the tidal current is often of more importance than the changing depth due to the tide; in fact, many mariners speak of "the tide" when they actually have the flow of the tidal current in mind. **Currents** can be defined as the horizontal movement of water, and may be classified as either tidal or nontidal.

**Tidal Currents.** These currents are caused by gravitational interactions between the Sun, Moon, and Earth just like the vertical rise and fall called tide, which we have discussed. Study the terms associated with tidal currents.

Term	Definition
Flood Current	When the horizontal movement of water is toward shore or up a tidal river or estuary, the current is said to be flooding.
Ebb Current	When the horizontal movement of water is away from shore or down a tidal river or estuary, the current is said to be ebbing.
Slack Water	The period of time where there is little or no current is called the minimum before flood or ebb.
Duration of Flood	The interval of time in which a tidal current is flooding.
Duration of Ebb	The interval in which the current is ebbing. In a normal semidiurnal tidal current, the duration of flood and duration of ebb will each be approximately 6 hours, but can vary.
Set	The direction of the current is called SET, and is expressed in the direction <b>TOWARD</b> which the current flows.
Speed of Current or Drift	The velocity of the current is called <b>speed of current</b> and is sometimes referred to as <b>drift</b> .

## Tidal Currents, Continued

---

**Nontidal Currents.** There are known and charted currents in all three of the major oceans that are classified as major currents. In the Pacific, the more important ones to note are the North Equatorial, South Equatorial, Equatorial Counter, Japan Stream, Oyashiwo, Californian, Australian, and Peruvian. In the Atlantic Ocean, the Gulf Stream is the most notable because of its clear definition as an ocean current and its effect on shipping and weather. Another type of tidal current you might encounter is called a **ROTARY** current. A rotary current is basically one that flows continually with the direction of flow changing through all points of the compass during the tidal period. Rotary currents are usually found offshore where the direction of flow is not restricted by any barriers.

---

### The Basics

**Tidal currents** are most pronounced in the entrances to large tidal basins that have restricted openings to the sea. Helmsmen should keep this fact in mind because they often experience difficulty in steering ships in tidal basins. Tide rips caused by swift tidal currents flowing over an irregular bottom often set up rips and eddies that are nearly always deceptive in appearance and will sometimes change a ship's course as much as 30°. One characteristic of a tide rip is in the coloring of the water. The line it caused may not always be straight, but it can usually be seen. You may also observe small wavelets caused by the wind. The water outside the current will often have many small wavelets, whereas the swift running current may be barren of wavelets; again, a quite visible line may be detected, giving the helmsman a clue to what may lie ahead as the ship passes from one side of the line to the other. Another clue for the helmsman is to observe the current trail streaming from a buoy.

In rivers or straits, or where the direction of flow is more or less restricted to certain channels, the tidal current is reversing; that is, it flows alternately in approximately opposite directions with an instant or short period of slack water at each reversal of the current. During the flow in each direction, the speed varies from zero, or near zero at the time of slack water to a maximum, either flood or ebb, about midway between the slacks.

# Tidal Current Tables

---

## Layout

Tidal Current Tables are tables that give daily predictions of the times and speeds of the tidal currents. The tables are issued annually in two volumes: one for the Atlantic Coast of North America and the other for the Pacific Coast of North America. These tables are set up basically the same as the Tide Tables. The Tidal Current Tables consist of five tables plus a number of current diagrams and data concerning wind-driven currents, the gulf stream, the combination of currents, and current diagrams. A brief discussion of the five tables is given below.

**Table 1 - Daily Current Predictions.** This table gives the predicted times of slack water and the predicted times and speeds of maximum current, both flood and ebb, for each day of the year at a number of reference stations. Also listed at the top of each page is the direction of set toward which the currents flow. Like the Tide Tables, data in this book are listed in standard time, so you must add 1 hour to convert the times to daylight savings time.

**Table 2 - Current Differences and Other Constants and Rotary Currents.** This table lists data for subordinate stations. When this data is applied to the predicted times and speeds at the appropriate reference stations, reasonable approximations of the current at the subordinate station may be computed. Later in this assignment, we will use tables 1 and 2 to calculate the speed of current at a subordinate station.

**Table 3 - Speed of Current at Any Time.** This table allows you to calculate the current at any time, not just the time of slack and maximum current. We will work an example problem later in this assignment.

**Table 4 - Duration of Slack.** This table provides a means of calculating the approximate period of time during which weak currents not exceeding 0.1 to 0.5 knots will be encountered. This duration includes the last of the flood or ebb and the beginning of the following ebb or flood, or half the duration will be before and half after the time of slack water. Buoy tender sailors may find this table helpful if an aid to navigation can only be worked safely at slack water.

**Table 5** - This table lists data for a number of offshore stations for the direction and average speed of the rotary tidal current for each hour of the tidal cycle.

# Current Calculations

## Example of Current Problems

In the following example, we will calculate the times of the minimum currents and the times and speed of the maximum currents on the morning of 8 September 1993 at a location known as **Sewells Point**. All of the figures in these examples are excerpts from the Tidal Current Tables.

OPNAV 3530/40 (4-73) HT OF TIDE	<b>Step</b>	<b>Action</b>	Completed Strip Form
Date	1.	Enter the desired date.	08 SEP 93
Location	2.	Enter the location. Look up Sewells Point alphabetically in the <b>index to stations</b> . The <b>index to stations</b> is located in the back of the Tidal Current Tables. Find the index number (#5121) for Sewells Point, note this number because you will use it in step 4.	Sewells Point
Time	3.	Enter the desired time.	1100
Ref Station	4.	The <b>reference station</b> is found by first finding our local or subordinate station (Sewells Point) #5121, in table 2, and then look in the center of the DIFFERENCE column and follow it upward to the line entitled "on Chesapeake Bay Entrance p. 44."	Chesapeake Bay Entrance p. 44

### Chesapeake Bay Entrance, Virginia, 1993

F—Flood, Dir. 300° True E—Ebb, Dir. 129° True

July			August			September			
Slack	Maximum		Slack	Maximum		Slack	Maximum		
7	0117 0443 1.2E	22	0058 0419 1.0E	7	0143 0511 1.1E	22	0200 0539 1.0E	7	0211 0659 1.0E
W	0806 1019 0.8F	Th	0733 1001 1.0F	Sa	0948 1116 0.8F	Su	0844 1124 1.2F	Tu	0924 1200 0.8F
	1312 1646 1.1E		1310 1633 1.0E		1417 1748 0.9E		1451 1822 1.5E		1514 1851 0.8E
	2000 2237 0.9F		1941 2217 1.2F		2107 2336 0.8F		2128 2351 0.9F		2217
8	0151 0524 1.2E	23	0138 0511 1.0E	8	0214 0563 1.1E	23	0252 0638 1.5E	8	0031 0431 0.4F
Th	0850 1108 0.8F	F	0822 1063 1.1F	Su	0826 1201 0.8F	M	0842 1222 1.1F	W	0246 0649 1.0E
	1400 1736 1.0E		1408 1736 1.4E		1506 1837 0.8E		1557 1925 1.3E		1012 1246 0.6F
	2048 2323 0.8F		2039 2311 1.1F		2197		2233		1817 1942 0.7E
9	0222 0603 1.1E	24	0229 0606 1.5E	9	0248 0636 1.1E	24	0050 0737 0.7F		2315
F	0935 1158 0.8F	Sa	0913 1150 1.1F	M	1011 1248 0.6F	Tu	0351 0739 1.5E	9	0118 0332 0.3F
	1451 1829 0.9E		1512 1840 1.4E		1804 1824 0.7E		1048 1323 0.9F	Th	0332 0739 1.0E
	2139		2141		2252		1708 2031 1.2E		1108 1337 0.6F
							2342		1817 1942 0.7E
									2315
									2322
									0334 0719 1.3E
									1025 1300 0.8F
									1840 2008 1.2E
									0134 0.5F
									0445 0824 1.2E
									1137 1408 0.7F
									1751 2119 1.1E
									0031 0249 0.5F
									0553 0936 1.1E
									1247 1544 0.7F
									1855 2226 1.1E

28NVJ077

Figure 7-9. Excerpt from Tidal Current Tables.

## Current Calculations, Continued

OPNAV 3530/41 (4-73) VEL OF CURRENT	Step	Action	Completed Strip Form
Time Diff Slack Water	5.	Inspect reference station time data. Determine whether the desired time falls between flood or ebb times. In our case the current is flooding. We need to know this to determine which slack water time difference to use. Table 2 labels slack water as Min. before Flood or Min. before Ebb. Enter the time difference.	- 0 41
Time Diff Max Current	6.	Enter the flood time difference.	- 0 47
Vel Ratio Max Flood	7.	Follow the data to the right and find the values for velocity ratios and directions from the SPEED RATIOS and AVERAGE SPEED AND DIRECTIONS columns.	1.1
Vel Ratio Max Ebb	8.	Enter ratio.	1.0
Flood Dir	9.	Enter direction.	195°
Ebb Dir	10.	Enter direction.	000°



# Current Calculations, Continued

No.	PLACE	Meter Depth	POSITION		TIME DIFFERENCES			
			Latitude	Longitude	Min. before Flood	Flood	Min. before Ebb	Ebb
HAMPTON ROADS—cont. Time meridian, 75° W		ft	North	West	h m	h m	h m	h m
	Willoughby Bay entrance		36° 57.7'	76° 17.9'	-2 12	-1 55	-2 21	-2 19
→ 5121	Sewells Point, channel west of		36° 57.5'	76° 20.4'	-0 41	-0 47	-1 23	-1 11
5126	Norfolk Harbor Reach (Buoy R '8')	13d	36° 57.00'	76° 20.37'	-0 18	-0 42	-1 36	-0 16
	do.	42d	36° 57.00'	76° 20.37'	-0 33	-1 00	-0 22	+1 04
5131	Sewells Point, pierhead <i>Newport News</i>	7	36° 56.8'	76° 20.1'	-0 52	-0 40	-1 01	-1 04
5136	Channel, middle	15	36° 57.3'	76° 22.9'	-0 43	-0 23	-0 12	-1 01
5141	Channel, west end	15	36° 57.20'	76° 24.80'	-0 16	-0 20	+0 03	-0 09
5146	Middle Ground, 1 mile south of	7	36° 56.0'	76° 23.2'	+0 33	+0 50	+0 24	+0 26

SPEED RATIOS		AVERAGE SPEEDS AND DIRECTIONS							
Flood	Ebb	Minimum before Flood		Maximum Flood		Minimum before Ebb		Maximum Ebb	
		knots	Dir.	knots	Dir.	knots	Dir.	knots	Dir.
0.4	0.3	--	--	0.3	135°	--	--	0.4	330°
1.1	1.0	--	--	0.9	195°	--	--	1.2	000°
0.8	0.7	--	--	0.6	183°	0.1	094°	0.9	011°
0.6	0.3	--	--	0.5	152°	--	--	0.3	000°
0.7	0.6	--	--	0.6	195°	--	--	0.6	010°
1.3	0.8	--	--	1.1	244°	--	--	1.1	076°
0.8	0.5	--	--	0.7	280°	0.1	010°	0.6	092°
1.4	1.0	--	--	1.1	270°	--	--	1.2	100°

26NVJ078

Figure 7-10. Excerpt from Tidal Current Table.

## Current Calculations, Continued

OPNAV 3530/41 (4-73) VEL OF CURRENT	<b>Step</b>	<b>Action</b>	<b>Completed Strip Form</b>
Ref Sta Slack Water Time	11.	Enter the reference station slack water time.	1012
Time diff	12.	Enter the time difference for slack water from step 5.	- 0 41
Local Sta Slack Water Time	13.	Apply the time correction.	0931
Ref Sta Max Current Time	14.	Enter the reference station maximum current time.	1246
Time Diff	15.	Enter the time difference for slack water from step 5.	-0 47
Local Sta Max Current Time	16.	Apply the time correction.	1159
Ref Sta Max Current Vel	17.	Enter the maximum current velocity.	.6 F
Vel Ratio	18.	Enter the velocity ratio for flood from step 7.	1.1
Local Sta Max Current Vel	19.	Multiply the values from steps 17 and 18 to find the maximum current velocity at Sewells Point.	.66 kt F
Int Between Slack and Desired Time	20.	Find the difference between the time of slack water and our desired time of 1100.	1 h 29 m
Int Between Slack and Max Current	21.	Find the difference between the time of slack water and maximum current.	2h 28m
Max Current	22.	Enter the value from step 19.	66
Factor Table 3	23.	Enter factor table 3 with the values from steps 2 1 and 21. Note the table value.	.8
Velocity	24.	Multiply the value from steps 22 and 23. Round to the closest tenth of a knot.	528 rounded to .5 kt
Direction	25.	Enter the direction of the flood current from step 9.	195°

# How to Graph Tidal Currents

---

## Procedure

The graphing of current velocity information is generally the same as graphing tide data. The most important difference is that tide height changes at a fairly constant rate. Current velocity on the other hand is related to many factors; for complete information on current velocity, refer to *Duttons*, chapter 10.

We can use the times between slack water and maximum current to plot our data. Table 4 can help us determine the amount of time a current is weak and it should also help us make an educated guess of how steep a curve must be plotted.

You may want to overlay the current data on the same graph as the one that has tide data for the same period. If this is the case, it is normally acceptable to omit drawing curves for the current data. Instead, you would draw straight lines between slack water and maximum current. At the intersection of each line, annotate SW for slack water and MC for maximum current respectively. If you do choose to overlay, make sure you use different colors of ink, one that represents tide data and one that represents current data.

---

## What's Next

In our next chapter you'll learn how the Quartermaster keeps track of the ship's position.



# Chapter 8

## Dead Reckoning, Piloting, and Electronic Navigation

---

### Introduction

In this chapter, you will learn how to keep track of the ship's position. It is extremely important that the QMOW be able to quickly estimate the ship's position at any time. Dead reckoning (DR) is one of the most basic and widely used methods of navigating. Dead reckoning is always employed any time a vessel is under way.

The primary reason for using dead reckoning is that the navigator may at any time give a reasonable account of the ship's position without having to take sights or obtain a position from other means. In many places on Earth, a vessel may get beyond the range of today's sophisticated navigational aids and have to rely on methods as old and time tested as the DR. Many vessels have been under way for weeks at a time without having made a landfall or having any other contact with shore and have still come within a very few miles of the desired destination using only a carefully maintained DR plot.

The practice of maintaining a DR plot will be the first task we focus on in this chapter. Piloting will be the second main focus of this chapter. Perhaps you recall from chapter 1 that the QM uses visual aids to establish the ship's position when piloting. Electronic navigation uses several pieces of electronic equipment. State of the art equipment is often used. Currently, the Navy's cutting edge electronic navigation equipment is the WRN-6 Satellite Navigation Set.

---

### Objectives

The material in this chapter will enable you to:

- Identify the primary reason for using dead reckoning, and match plotting instruments and tools with their usages.
- State how you obtain true or magnetic course using the compass rose.
- State the purpose of a course line, and identify the proper method of labeling course lines.
- State the two factors considered when using the dead reckoning process.
- Match the plotting symbols with their appropriate meaning: DR, EP, visual fix, and electronic fix.
- Calculate speed, time, and distance problems using the formula  $D = S \times T$ , the nautical slide rule, and the 3-minute rule.
- List three methods used to measure a ship's speed through the water,

# Topics

<b>Topic</b>	<b>Page</b>
The DR Plot	8-3
Terms Associated With the DR Plot	8-4
Time, Speed, and Distance	8-5
Using the Nautical Slide Rule	8-7
Practice Time, Speed, and Distance Problems	8-8
Example DR Plot	8-10
Labeling the DR Plot	8-11
Plan of Intended Movement (PIM)	8-12
Plotting Instruments	8-13
Plotting Techniques	8-15
Labeling the Course Line	8-17
Piloting	8-18
Lines of Position and Fixes	8-20
Determining the Ship's Position Using True Bearings	8-21
Determining the Ship's Position Using Relative Bearings	8-22
The Marine Sextant	8-24
Determining the Ship's Position Using Sextant Angles	8-33
Determining the Ship's Position by Running Fix	8-39
Using the Fathometer	8-41
Loran Time Difference Lines	8-43
Satellite Navigation Systems	8-44
Navigational Radar	8-49
Other Electronic Navigation Equipment	8-53

# The DR Plot

---

## General Information

The importance of maintaining an accurate dead reckoning plot cannot be overemphasized. Since other means of fixing your ship's position may not always be available, a navigator must rely on a DR plot.

If a ship made good the exact course and speed ordered, and there was no wind or current, dead reckoning would, at all times, provide an accurate indication of the ship's position. A navigator must know the position, or approximate position, to determine when to make changes in course and/or speed, to predict the time of sighting lights or other aids to navigation, and to identify landmarks.

---

## Rules

When maintaining a DR plot, there are six rules that govern what actions the QM should take. These rules are not subject to interpretation, they are hard and fast. Often, when the ship is changing course it becomes tedious to maintain the DR plot. This is a given and known fact; however, the importance of keeping the plot up to date can't be stressed enough.

These rules specify when a DR position shall be plotted:

#	Rule
1.	A DR position shall be plotted each hour on the hour.
2.	A DR position shall be plotted at the time of every course change.
3.	A DR position shall be plotted at the time of every speed change.
4.	A DR position shall be plotted at the time of a fix or running fix.
5.	A DR position shall be plotted at the time of obtaining a single LOP.
6.	A new course line shall be plotted from each new fix or running fix.

## Terms Associated with the DR Plot

**Definition Table** Use the following table to identify and learn the meanings of terms associated with DR:

Term	Definition
Heading	The ship's heading is always expressed in degrees measured clockwise from 000° through 360°. Commonly referred to as the ship's head, the heading can be referenced from true north, magnetic north, or compass. The ship's head is always changing due to the constant yawing motion caused by the effects of the sea and steering errors.
Course	The course is the direction on which the ship is to be steered. As an example, the helmsman is ordered to <u>come left steer new course 090° T</u> . The helmsman would respond by putting the rudder left and steadying the ship on new course 090°T.
Course Line	The course line is the graphical representation of the course that is being steered laid on to the chart. Looking back at our example, let's assume the original course was 094°T. The chart would have had a 094°T course line laid on it. When the helm was ordered to steer 090°T, a new course line of 090°T would be laid on the chart.
Speed	This is the ship's ordered speed. For example, let's assume that ordered speed is 12 knots. For purposes of DR, we assume that the ship will travel 12 nautical miles in 1 hour
DR Position	This position is determined by laying out the ship's course (course line) and speed on the chart. A DR position does not take into account any current that may speed or slow the ship.
Estimated Position	This is a best guess position using available information. In practical usage, it starts with the DR position and adds other data such as the estimated speed and set of the current.
Fix	This position is established at a specific time that is believed of high accuracy. With the recent addition of Global Positioning System (GPS) WRN-6 satellite fix data, it is now possible to obtain a highly accurate fix 24 hours a day.



# Time, Speed, and Distance

---

## Basics

Time, speed, and distance are related by the formula:  
distance = speed x time. Therefore, if any two of the three quantities are known, the third can be found. The units must be consistent. (The distance scales on nautical charts use nautical miles and yards, unless otherwise stated on the chart. A nautical mile is equal to 2,000 yards.) Thus, if speed is measured in knots and time in hours, the answer is in nautical miles. Similarly, if distance is measured in nautical miles and time in hours, the answer is in knots. If distance is measured in yards and time in minutes, the answer is in yards per minute.

Table 19 of *Bowditch* is a speed, time, and distance table that supplies one of the three values if the other two are known. It is intended primarily for use in finding the distance steamed in a given time at a known speed.

---

## Solving the Time, Speed, and Distance Triangle

The following formulas may be used if the speed is measured in knots, the distance in nautical miles, and the time in hours and/or tenths of hours (0.1 hour = 6 minutes).

$$\text{Distance} = \text{Speed} \times \text{Time}$$

$$\text{Speed} = \text{Distance} \div \text{Time}$$

$$\text{Time} = \text{Distance} \div \text{Speed}$$

**Example 1.** Your ship steams for a period of 4 1/2 hours and covers a distance of 54 nautical miles. What is your speed?

$$S = \frac{D}{T} \quad S = \frac{54}{4.5} \quad S = 12 \text{ knots}$$

In example 1, time was given in hours and tenths. When time is given or required in minutes, the same formulas, slightly changed, are still used.

## Time, Speed, and Distance, Continued

---

$$\text{Distance} = \frac{\text{Speed} \times \text{Time}}{60} \text{ ( minutes)}$$

$$\text{Speed} = \frac{\text{Distance} \times 60}{\text{Time}}$$

**Example 2.** How many minutes (m) are required for a vessel to steam a distance of 7 nautical miles at a speed of 7.5 knots?

$$T(m) = \frac{D \times 60}{S} \quad T(m) = \frac{7 \times 60}{7.5}$$

$$T(m) = \frac{420}{7.5} \quad T = 56 \text{ minutes}$$

The following is an aid to help you remember these formulas.

Simply place the letters in a triangle, as shown in figure 8-1. For distance (D), place your finger over the D and you have S x T. For speed (S), cover the S and you have D ÷ T. For time (T), cover the T and you have D ÷ S

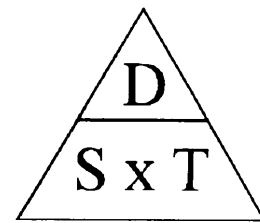

26NVM001

Figure 8-1.  
T, S, and D  
triangle.

---

### 3-Minute Rule

Another way of solving problems of distance, speed, and time is by using the 3-minute rule. The 3-minute rule will help solve mathematical computations without a nomogram or calculator. The rule states:

The distance traveled in yards over 3 minutes divided by 100 equals the speed in knots. To simplify, just drop two zeros from any distance traveled in yard in any 3 minute period.

Example 1: Ship travels 1,600 yd. in 3 min.  $1,600/100 = 16$  (Speed is 16 knots).

Example 2: Ship's speed is 16 kn for 3 min.  $16 \times 100 = 1,600$  yd.

# Using the Nautical Slide Rule

## Procedure

To simplify speed, time, and distance solutions, most Quartermasters use a circular slide rule (fig. 8-2), commonly known as a nautical slide rule. When you enter two known variables on the appropriate scales, the third value can be found.

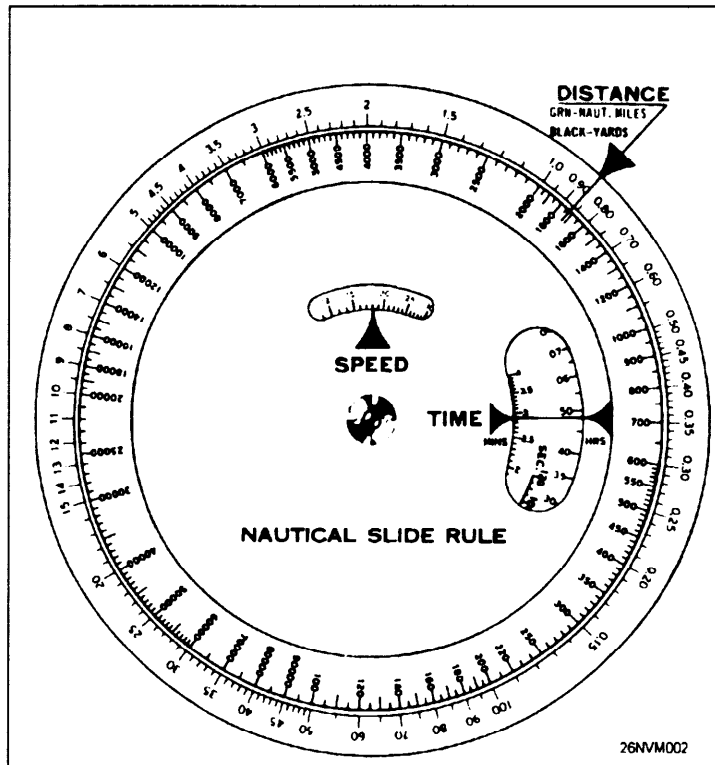

Figure 8-2. Nautical slide rule.

## Caution

Do NOT rely solely on the nautical slide rule to calculate time, speed, and distance problems. A problem will surely arise when the slide rule is not available. Additionally, you cannot use a nautical slide rule when taking advancement examinations.

# Practice Time, Speed, and Distance Problems

---

1. Using the formula for solving time, speed, and distance problems, solve each of the following:

	<b>TIME</b>	<b>SPEED</b>	<b>DISTANCE</b>
a.	_____	14 kt	146 nmi
b.	12 min	_____	.6 nmi
c.	73.5 hr	16 kt	_____
d.	76 hr	_____	874 nmi
e.	9h.r	8 kt	_____
f.	_____	15 kt	1485 nmi
g.	_____	18 kt	918 nmi
h.	11 hr	_____	132 nmi

2. The 3-minute rule simply states that distance traveled in yards in \_\_\_\_\_ minutes divided by \_\_\_\_\_ equals \_\_\_\_\_.

3. Using the 3-minute rule, solve each of the following, rounding to the nearest tenth where required.

	<b>TIME</b>	<b>SPEED</b>	<b>DISTANCE</b>
a.	3 min	_____	750 yd
b.	6 min	_____	1420 yd
c.	3 min	_____	765 yd
d.	6 min	_____	1140 yd
e.	3 min	_____	414 yd
f.	3 min	_____	840 yd

# Measuring the Ship's Speed

## Methods

Speed can be determined directly using special instruments or indirectly by means of distance and time.

The first method of measuring a ship's speed and distance involves the use of instruments that directly measure a ship's motion through the water. Such instruments are called logs. The three types of modern logs in common use today are: the pitot-static log, the impeller log, and the electromagnetic log. Figure 8-3 is an example of a speed log indicator. Each of these logs requires the use of a device called a rodmeter, which is basically a blade or rod that is projected through the bottom of the hull. The rodmeter contains the sensing devices that determine speed. You must be careful not to lower the rodmeter in shallow water as it may strike the bottom.

Another way of determining speed and distance is indirectly using engine or shaft revolutions. This data can be derived, or verified, by running the ship over a measured mile. To do this, you run the measured mile at given engine rpm's, and note the time it takes you to travel the mile. Then using the speed, time, and distance formulas previously given, you determine the speed for that rpm. A table, graph, or both are then prepared that relate rpm to ship's speed.

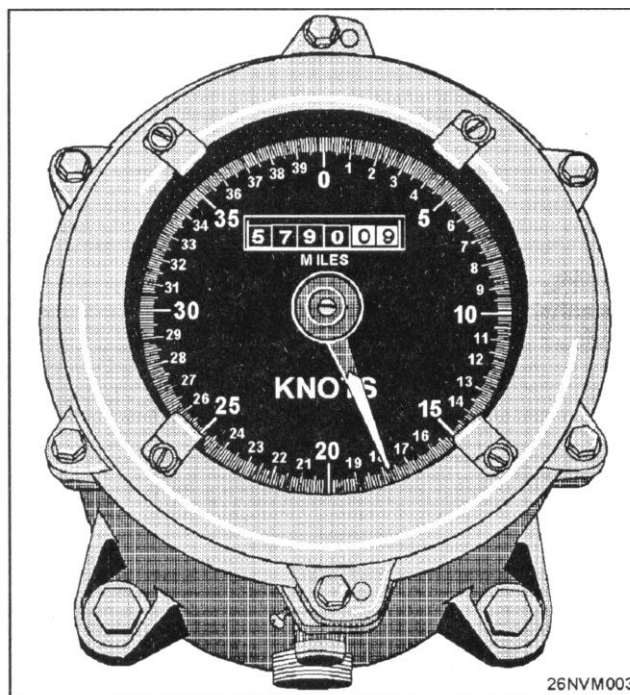

Figure 8-3. Speed log indicator.

# Example of a DR Plot

## Example

Figure 8-4 represents a sample DR plot. At 0900 your ship departs point A en route to point B on course 090°T, speed 12 knots. In this particular example, DRs are laid out every hour; you expect to arrive at point B at 1300.

At 1200, you obtain a fix which places your ship 180°T, 5 miles from your 1200 DR position (point X). If you were to maintain your original course of 090°T, you will miss your destination; therefore, a correction is necessary.

Since time was required to record and evaluate your fix and to decide a new course and speed to reach your destination (point B), the change cannot occur at the 1200 fix. Instead, you must DR ahead some point in time. In this case, the navigator plots a 1210 DR position based on the old, and still maintained, course and speed. From here the navigator calculates the new course of 050° T, speed 15 knots. It is important to remember that the course line will continue in the direction and speed originally ordered during the time spent obtaining and plotting the fix and while deciding a new course and speed.

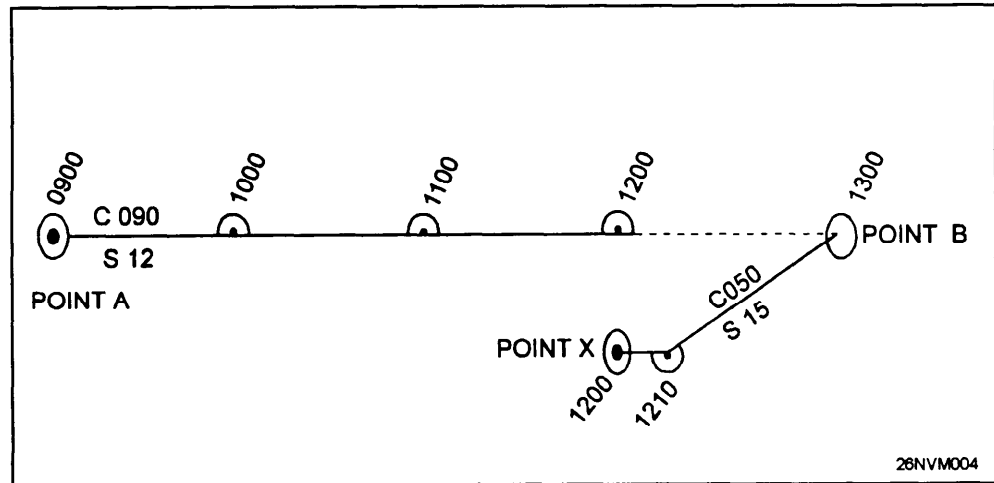





Figure 8-4. Example DR plot.

## Labeling the DR Plot

### Symbols

The symbol for a DR position is a small semicircle around a small dot on a straight segment of a course line (fig. 8-5); it will be more or less than a semicircle when plotted at a change in direction. The letters DR are not used. Time, to the nearest minute, stated in the 24-hour system as a 4-digit number is written nearby. All symbols for labeling positions are also shown.

SYMBOL	DESCRIPTIVE LABEL MEANING
	FIX AN ACCURATE POSITION DETERMINED WITHOUT REFERENCE TO ANY PREVIOUS POSITION. ESTABLISHED BY VISUAL OR CELESTIAL OBSERVATIONS.
	FIX A RELATIVELY ACCURATE POSITION, DETERMINED BY ELECTRONIC MEANS. THIS SYMBOL IS ALSO USED FOR A FIX WHEN SIMULTANEOUSLY FIXING BY TWO MEANS, e.g., VISUAL AND RADAR; SOMETIMES USED FOR RADIO/NAVIGATION FIXES, WITHOUT REFERENCE TO ANY FORMER POSITION.
	DR DEAD RECKON POSITION. ADVANCED FROM A PREVIOUS KNOWN POSITION OR FIX. COURSE AND SPEED ARE RECKONED WITHOUT ALLOWANCE FOR WIND OR CURRENT.
	EP ESTIMATED POSITION. IS THE MOST PROBABLE POSITION OF A VESSEL, DETERMINED FROM DATA OF QUESTIONABLE ACCURACY, SUCH AS APPLYING ESTIMATED CURRENT AND WIND CORRECTIONS TO A DR POSITION.

28NVM005

Figure 8-5. Symbols used for labeling positions along a course line.

Answers:

1. a. 10.4 hrs, b. 3 k, c. 1176 nmi, d. 11.5 k, e. 72 nmi, f. 99 hrs, g. 51 hrs, h. 12 k.
2. 3/100/speed in knots
3. a. 7.5 k, b. 7.1 k, c. 7.7 k, d. 5.7 k, e. 4.1 k, f. 8.4 k

# Plan of Intended Movement (PIM)

## Basics

Prior to any ship getting under way, a PIM must be formed. Normally, the senior Quartermaster and the navigator will discuss the best possible routes for the ship to follow. Messages are then sent to group commanders and the ship gets under way. As the QMOW, you will be tasked with tracking the ship's progress.

Tracking is directly related to time, speed, and distance calculation. Figure 8-6 represents a ship's track with PIM times and dates annotated. As a rule, PIM is laid out for every 4 hours GMT. When referring to the ship's position in relation to PIM, you should express any values as time ahead or behind PIM. Let's look at an example.

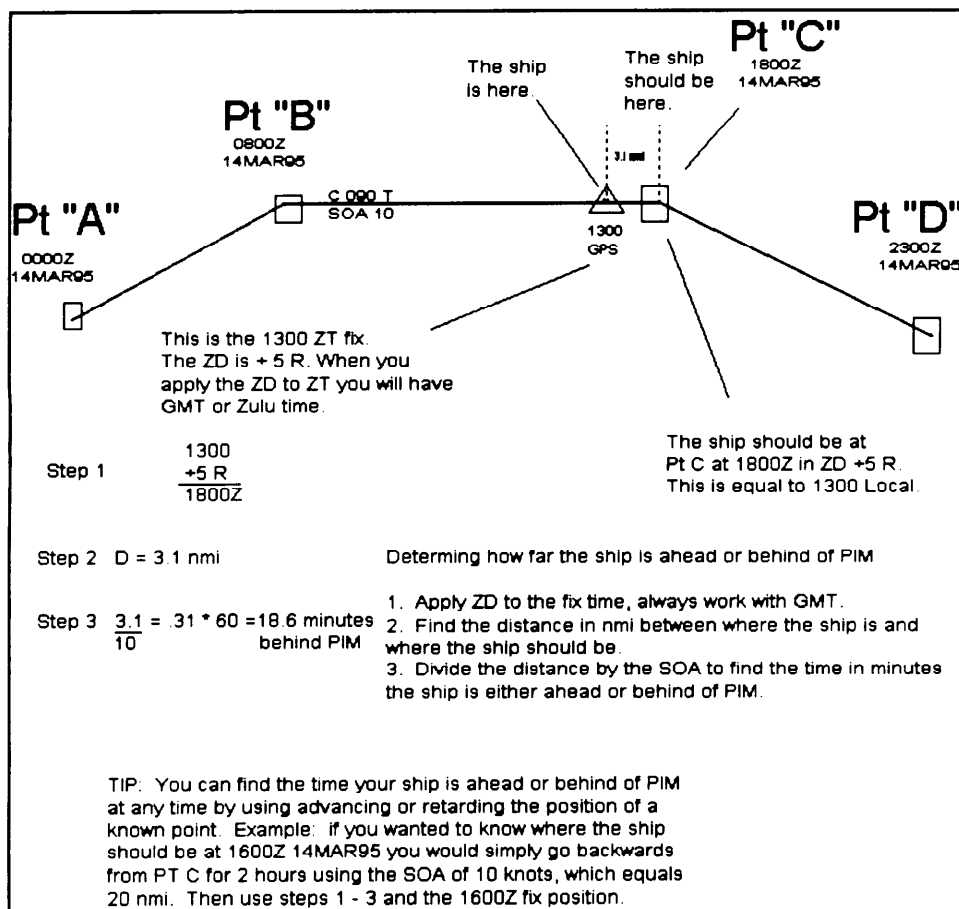

Figure 8-6. Example PIM calculation.



# Plotting Instruments

## Basics

Let's put together what we've learned about the DR plot, the tools of the trade, and the techniques the Quartermaster uses.

Tools used to project lines, scribe arcs, measure angles and distances, and do a host of other jobs are just some of the hand tools you will use as a Quartermaster. Items such as pencils, parallel rulers, compasses, and dividers are a MUST on any bridge or in any chart room.

## Tools of the Trade

**Pencils:** Primary among these tools is the pencil you use. There are several grades or hardness of lead. The softer grades, such as the No. 2, are ideal for plotting positions on the chart and for other general uses around the bridge. No. 3 pencils are considerably harder, will hold a point longer, and will usually sharpen better for use in drawing fine lines as will be required when the QM wants to plot stars, draw course lines, or do other chart work that requires the use of better than average lines to show the condition to be depicted. Under most conditions, only the Nos. 2 and 3 grade pencils will be necessary.

**Parallel Rulers:** Parallel rulers are instruments used for moving lines parallel to themselves, determining direction from the compass rose, and laying out course lines. These are, of course, only a few of the uses of parallel rulers. Some of the other uses include drawing straight lines, advancing lines of position, checking ranges, plotting fixes, and measuring direction from one given point to another. There are other devices available which are easier to use and will do the same job as parallel rulers. The Weems parallel plotter (fig. 8-7) is the most widely used variation of the parallel ruler.

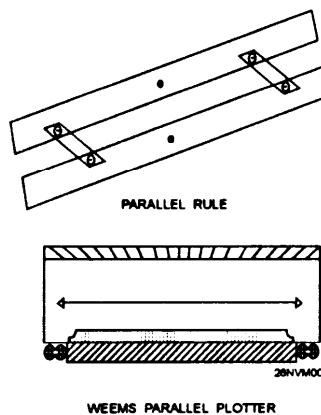

Figure 8-7. A parallel rule (top) and a Weems parallel plotter.

## Plotting Instruments, Continued

### Tools of the Trade, continued

**Compasses:** Compasses are not to be confused with the direction finding compass such as the magnetic or gyrocompass. The compasses referred to here are tools that are very similar in appearance to the divider. The distinction between dividers and compasses is that while both divider legs are fitted with needles, the compass legs are fitted with a needle on one leg and a marking lead or pencil on the other.

Compasses are useful for scribing circles and arcs such as radar ranges or perhaps showing the limits of a light's visibility. Dividers and compasses (fig. 8-8) will give best results when the adjustment screw at the hinged end is kept tight enough to permit ready use but prevent slippage. The needle points should be sharp, extended to the same length, and locked securely using the locking screw provided.

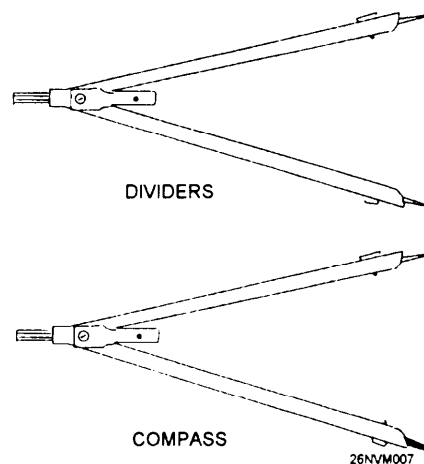

Figure 8-8. Compass and dividers.

A variation of the compass, called a beam compass, is used when a greater spread is required than an ordinary compass can accommodate. The beam compass is simply a long bar with a needle point at one end and a marking lead or pencil at the other end; both are adjustable. This compass is very useful when using large-scale charts such as harbor charts.

**Dividers:** A pair of dividers is an instrument or tool used to measure the difference between two given points. It consists of two small pieces of metal, plastic, or wood, hinged at one end, allowing the opposite ends to be separated. There are needles or points placed in the ends of both legs which enable the user to obtain a more accurate measurement and allow the tool to be swung from one length to another without slipping. There are many sizes of dividers, but the 5- and 6-inch sizes have been found to be the most popular and useful. Larger dividers are handy at times, but can be clumsy to use.

# Plotting Techniques

---

## General Procedure

To travel accurately and safely from point to point on Earth's surface, charts have been constructed to show the locations of most all prominent places. Using these charts, a navigator can plan the voyages. By drawing a line on the chart from one place to another, a navigator establishes a line known as a course line, the purpose of which is simply to provide a graphic representation of a vessel's course. Careful attention must be paid to ensure that there are no dangers to navigation, such as rocks, reefs, islands, and so forth, along the route of intended travel. From this line, the navigator determines the direction in which the ship must sail to arrive at the desired location. By measuring the distance between the two places and knowing the speed of the ship, the navigator computes how long the voyage will take.

As defined in the terms table, course (C) is horizontal direction of travel, expressed as angular distance from a reference direction, usually from  $000^\circ$  clockwise through  $360^\circ$ . For marine navigation, the term course applies to the direction to be steered, which sometimes differs from the direction you intend to make good over the ground. Course is most often designated as true, but may also be designated as magnetic, compass, or gyro.

Often while the ship is following the intended track, it will be necessary to change course to avoid other ships or make adjustments for current that sets the ship off the intended track.

Maintaining the DR plot is a matter of closely following the six rules of DR. Let's look at an example of what is required to maintain a sample plot. The example shown in figure 8-9 illustrates a typical DR plot. At 0900 your ship departs point A en route to point B on course  $065^\circ\text{T}$ , speed 10 knots. In this particular example, DRs are laid out every 30 minutes; you expect to arrive at point B at 1200. At 0941 you change course to avoid shipping traffic. At 1000 you obtain a fix which places your ship right of your track line. Based on the 1000 fix, you recommend course  $075^\circ\text{T}$  to arrive at point B on time.

## Plotting Techniques, Continued

---

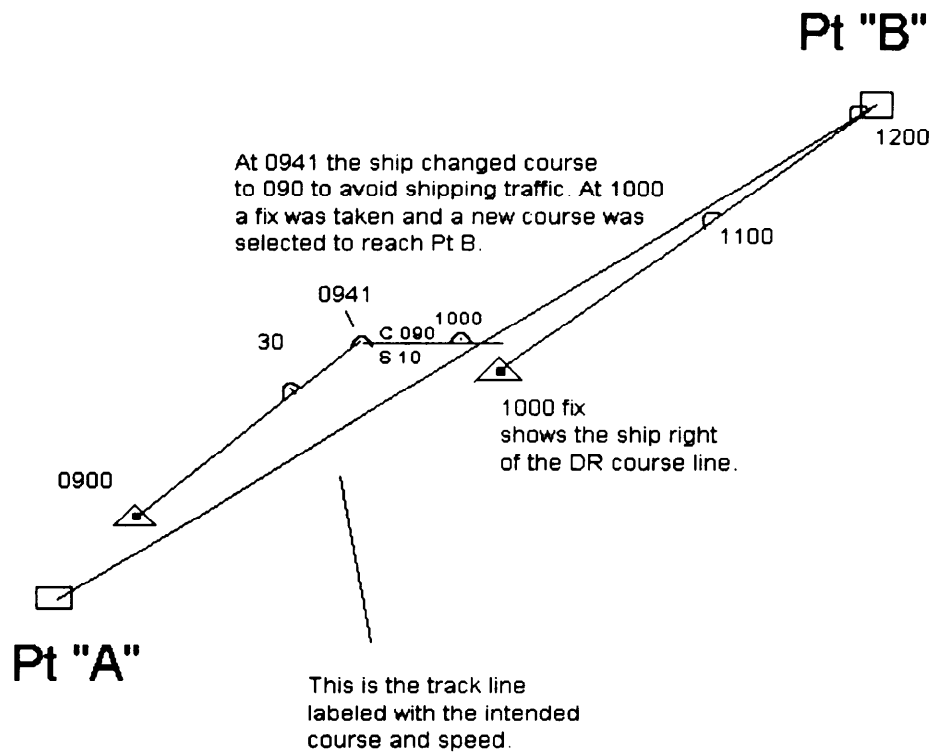

Figure 8-9. Sample plot.

---

This example is for illustration purposes only. In actual practice, the QMOW will normally obtain and plot a fix every hour while on the open ocean. The frequency of fixes is determined by the navigator. It is not unusual while in coastal waters for the QMOW to obtain and plot fixes each 1/2 hour or even every 15 minutes.

# Labeling the Course Line

## Procedure

Figure 8-10 shows a typical layout and labeling of course lines. The label for direction is the letter *C* followed by three digits indicating true course in degrees; this is placed above the course line. If course lines are based on magnetic headings, the letter *M* is added following the digits.

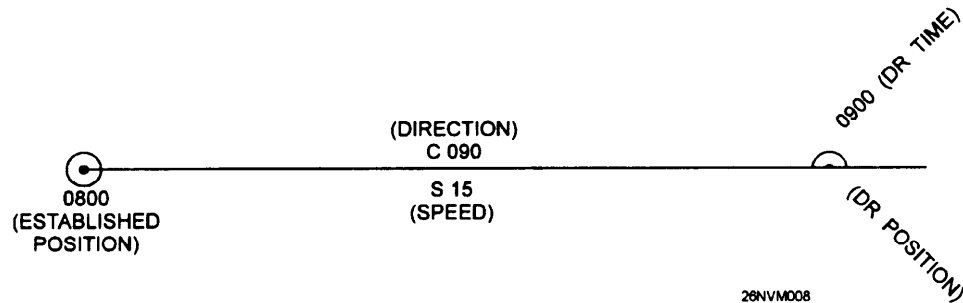

Figure 8-10. Labeled course line.

The intended speed, or the speed you wish to make good with respect to Earth, is known as speed of advance, or simply SOA. SOA is also used to designate the average speed that must be made good to arrive at a destination at a specified time. The letter *S* followed by numbers shows the intended speed. This is placed below the course line, usually directly beneath the direction label.

## Emergency Plotting

There are times when you will be required to plot positions in emergency situations. The most common of these is during man overboard events. Your reaction time is critical. The preferred method is to use the WRN-6 to enter a waypoint and then drive the ship back to that point. You may also use this method using commercial Loran C receivers. You must consult the WRN-6 or Loran C operators manuals for step by step instructions.

**Leading Petty Officers:** Post detailed man overboard procedures at the chart table on the bridge. Hold training frequently on procedures, strive to obtain fix data within 3 seconds from sounding man overboard alarm.

# Piloting

---

## Introduction

Navigation becomes more demanding when your ship is near land or in restricted waters where there is an immediate danger of possible grounding. Piloting is the process of safely directing the movement of a vessel from one point to another involving frequent or continuous determination of a ship's position relative to geographical points, to a high order of accuracy.

---

## Section Objectives

- List the three types of navigational observances used to determine a ship's position in piloting.
- Match the following navigation terms with their meanings:

a. true bearings	i. estimated position
b. relative bearing	f. piloting
c. fix	g. set & drift
d. speed of advance	h. line of position
e. course over ground	j. running fix
- List the procedures for obtaining visual bearings and radar ranges.
- State the best objects and proper order to obtain visual bearings and radar ranges.
- Convert relative bearings to true bearings.
- List the procedures for plotting a visual fix and a radar fix.
- List the procedures to set up and plot visual bearings with a PMP.
- List the methods used to compensate for gyro error on a PMP.
- State how to obtain a bearing and range from radar.
- Make proper entries in the Standard Navy Bearing Book.
- State the OPNAV instruction that regulates how to maintain a navigation plot.
- Identify the general requirements for LOPs when maintaining a navigation plot.

# Piloting

---

## The Navigation Team

Piloting must be done on a chart. You must construct a plot based upon accurate navigational observations of charted features. These observations of charted features include:

- bearings to visible objects
- distances to objects
- depth sounding

To effectively navigate in confined waters, a team of personnel must assist the navigator. The navigation team composition is as follows:

Position	Responsibilities
Navigator	All navigation functions.
Assistant navigator	Supervises navigation team, assists the navigator.
Plotter	Plots bearing on the chart, DRs, calculates set and drift.
Bearing takers	Takes bearings on objects as directed by the bearing recorder.
Bearing recorder	Relays bearing to the plotter, records bearings, provides all stations with marks.
Fathometer operator	Reports depth of the water on each mark.
CIC phone talker	Provides the bridge with navigation data from CIC as requested.

---

## The Navigation Brief

In all cases, a ship needs a plan of action prior to getting under way or entering port. This plan, called the Navigation Brief, is a detailed description of all aspects of the ship's actions while in piloting waters. Information concerning the ship's track, navigation aids to be used, tide and current data, emergency anchorages, and other data are all contained in the Navigation Brief.

The actual construction of the Navigation Brief will be covered in detail in chapter 12.

# Lines of Position and Fixes

---

## Defined

A line of position (LOP) is a line established by observations or measurement on which a vessel can be expected to be located. The concept of a LOP is extremely important in piloting. From a single LOP, one can safely assume that the ship is located somewhere along that line.

A LOP may be straight (for bearings) or curved (for ranges). To obtain a high degree of accuracy when fixing the ship's position, you must use three or more LOPs.

Accuracy: Factors such as chart errors, human limitations, and equipment errors may affect the accuracy of a LOP. The accuracy of any single LOP can be checked by comparison with two or more LOPS that are taken simultaneously. A bearing will be suspect if it plots away from two other LOPs.

---

## Fixes

A fix is the point of intersection of two or more simultaneously obtained LOPS indicating your ship's exact position on the chart. The accuracy of a fix obtained from two LOPS is almost always questionable. Since we have already stated that accuracy is of the utmost importance in piloting, you must always strive to obtain *three* or *more* lines of position for an accurate fix.

---

## Labeling LOPs

Any single LOP that is obtained must be labeled with the time that it was obtained. This is necessary if it is to be in a running fix. An unlabeled LOP can mistakenly be used and become a source of error.

In the practice of piloting, single LOPS are not common because bearings on objects are taken at the same time by the bearing takers. The fix resulting from these bearings is labeled with the time the bearings were taken.

---

## Selecting Landmarks for LOPS

The angle between selected objects is the most important factor to consider when selecting objects to fix the ship's position from. For three simultaneous LOPS to provide the best fix, they should be located 120° apart. This is often impossible in practical application. Normally, the assistant navigator or plotter will select possible objects to obtain bearing and the resulting fixes from. Use of conspicuous landmarks is always desirable. Lighted towers, water tanks, and buildings are some possibilities.



# Determining the Ship's Position Using True Bearings

## Procedure

The following table identifies the process of determining the ship's position by true bearings.

Step	Action
1.	The assistant navigator or plotter selects objects to shoot bearing on.
2.	The bearing recorder informs the bearing takers of the objects they are to shoot.
3.	At the appropriate time, the bearing recorder gives a 10-second standby and on the minute gives the order "MARK" to the bearing takers.
4.	At the exact moment, the bearing takers shoot and relay the values of the bearings to the bearing recorder.  <b>Rule:</b> It is common for both bearing takers to be required to shoot bearings on more than one object. Bearing takers <b>MUST</b> shoot objects closest to the beam of the ship first, then shoot objects closest to the bow, and finally objects closest to the stern.  <b>Memory Aid: BEAM, BOW, STERN</b>
5.	The bearing recorder relays the bearings to the plotter.
6.	The plotter plots all bearings, labels the resulting fix, determines set and drift, and DRs out on the track.
7.	The navigator analyzes the fix data and makes reports and recommendations on actions to be taken to the officer of the deck.

## Skills

The table explained only the process that is generally followed to fix the ship's position using true bearings. Learning the actual skills required to function as a member of the piloting team requires many hours of OJT and meeting requirements for PQS. Inexperienced QMs normally begin training on the piloting team as bearing takers and move to stations requiring more responsibilities as their individual skills progress.

# Determining the Ship's Position Using Relative Bearings

## Relative Bearings

A relative bearing refers to a bearing taken on an object relative to the ship's heading. They are measured from 000° through 360°.

**Example:** If a ship is on course 090° T and a bearing taker shoots light "A", 020° relative, this means that light "A" is 20° to the right of the ship's head. To convert relative bearings to true bearings, apply the formula  $SH + RB = (subtract\ 360\ from\ T\ if\ over\ 360^\circ)$ . SH is ship's head, RB is relative bearing, and T is the true bearing.

## When to Use Relative Bearings

In almost all cases, relative bearing navigation will be used when a casualty occurs to the gyrocompass. There are several methods available for use to find the ship's position using relative bearings. In this text, we will cover only the preferred method. Complete information on using relative bearings can be found in *Dutton's*.

## Procedure

Use the following table to use relative bearings to fix the ship's position.

**Rule:** The helmsman must mark the ship's head each time a round of bearings are taken; the bearing recorder must start a new column to record ship's head data.

Step	Action
1.	Direct bearing takers to shift to relative bearings using the outer ring of the pelorus; shoot a round of bearings.
2.	Align the PMP ruler to the ships head. <b>Example:</b> Cse 200° T
3.	With a sharp white grease pencil, mark compass deviation from the deviation tables onto the PMP scale. Remember + W - E.  <b>Example:</b> For 5° W deviation, mark 205° on PMP scale. 205° is the Compass Cse the helmsman must steer. When you recommend new courses, use magnetic courses indicated by the grease pencil mark.
4.	Now mark the 180° and 0° on the PMP scale with the grease pencil. Use these marks to align the relative bearings.
5.	Plot the round of bearings using the 180° and 0° grease pencil marks.

Figure 8-11 on the following page shows a PMP that is set up for relative bearing navigation.

# Determining the Ship's Position Using Relative Bearings,

Continued

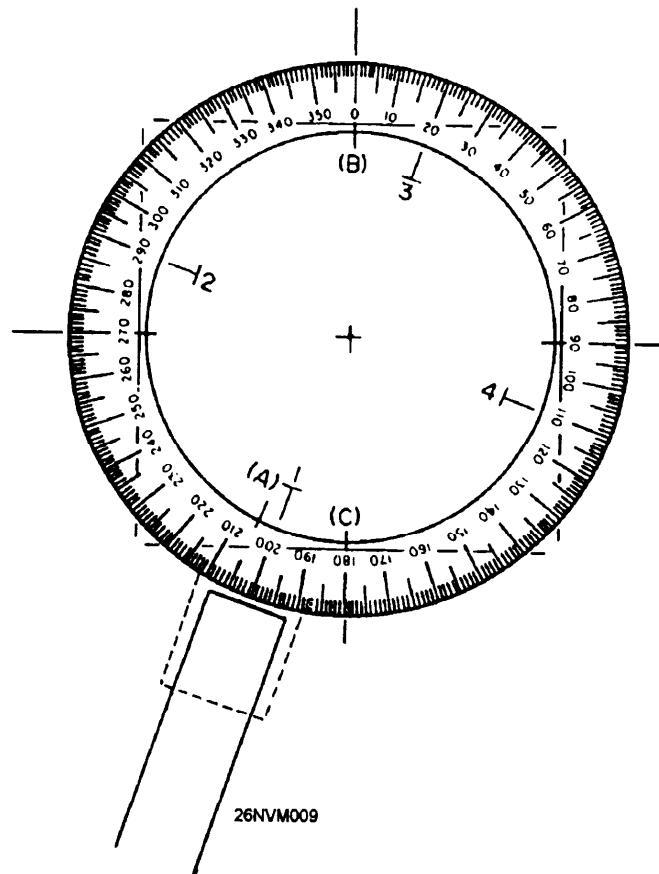

Figure 8-11. PMP set up for relative bearing navigation.

---

## Accuracy

The results of a relative bearing fix are directly related to the accuracy of the deviation table. If the compass deviation listed is in error by  $2^\circ$ , then all bearings may be off by  $2^\circ$ . There is a way to check the accuracy of the deviation tables for any area in which the ship is operating. Comparing the deviation table to the entries in the Magnetic Compass Record Book may at times give an indication to the accuracy of the deviation tables. Often, interpolation is required. Any decision to deviate from values given in the deviation tables must be made by the navigator and recorded in the Standard Bearing Book.

# The Marine Sextant

## The Marine Sextant

The marine sextant's only function is to measure angles, either horizontally or vertically. The most common use of the sextant is for celestial observations using vertical angles between celestial objects and the horizon. It is also used for fixing your position using horizontal angles between three charted objects. In this chapter, we will concern ourselves with the latter method. Before we can learn how to fix the ship's position using the marine sextant, we need to learn how to operate the marine sextant. Figure 8-12 shows the parts of a marine sextant.

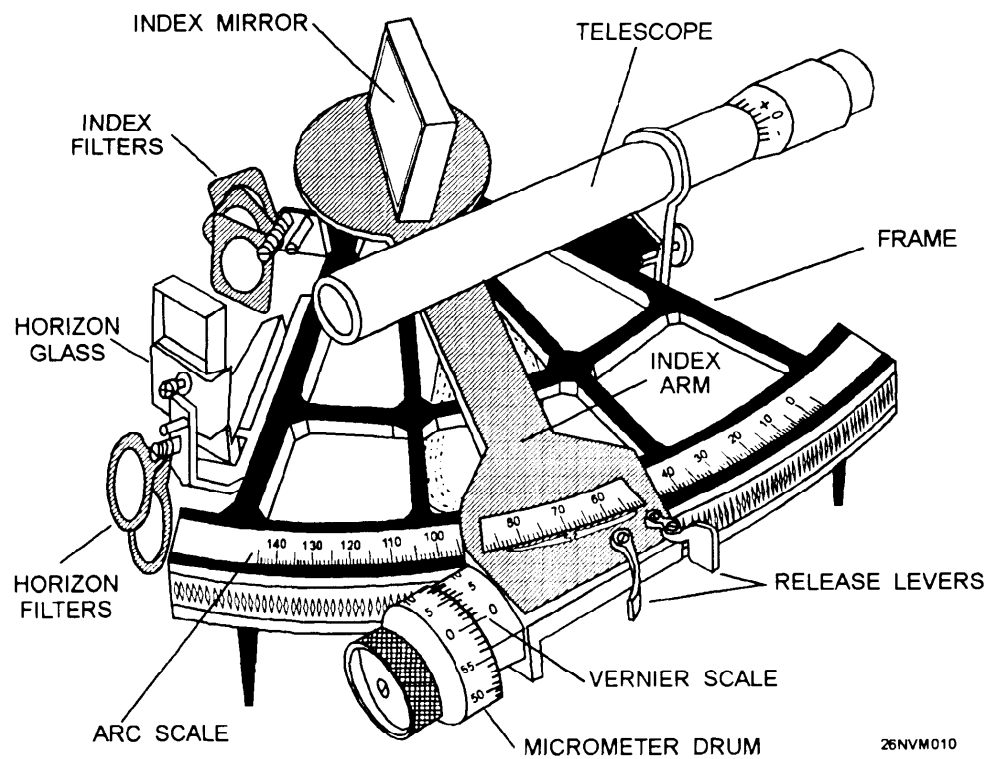

26NVM010

Figure 8-12. The marine sextant.

## The Marine Sextant, Continued

### Parts and Functions

These are the parts and functions of the marine sextant:

<b>Part</b>	<b>Description of Function</b>
Arc scale	Indicates the number of degrees of an angle.
Index arm	Pivots at one end to allow the attached index mirror to reflect an object onto the horizon glass and swings along the arc scale on the other end to indicate what the angle measures.
Micrometer drum	Rotates to make fine adjustments when measuring angles and indicates minutes of a degree of angle. It is attached to the lower end of the index arm. One complete rotation moves the index arm $1^\circ$ along the arc scale. The drum has 60 graduations, each representing 1' of arc.
Vernier scale	Indicates tenths of a degree of angle. It is attached on the index arm adjacent to the micrometer drum and has 10 graduations, each representing 0.1' of arc.
Index mirror	Reflects objects onto the horizon glass.
Horizon glass	Allows the observer to view one object directly on one side while observing a second object reflected next to it. The half of the horizon glass next to the frame is silvered to make that portion of the glass a mirror; the other half is clear glass.
Telescope	Directs the line of sight of the observer to the horizon glass and magnifies the objects observed.
Filters	Protects the observer's eyes when viewing the Sun.
Release levers	Disengages the index arm from the arc scale to allow the index arm to move freely.

## The Marine Sextant, Continued

### How a Sextant Works

A reflected object from the index mirror can be brought into line with an object viewed directly by moving the index arm along the arc scale until the reflected object can be seen in the horizon glass. The angle measurement is read off the arc scale, micrometer drum, and vernier scale. Figure 8-13 shows how a sextant works.

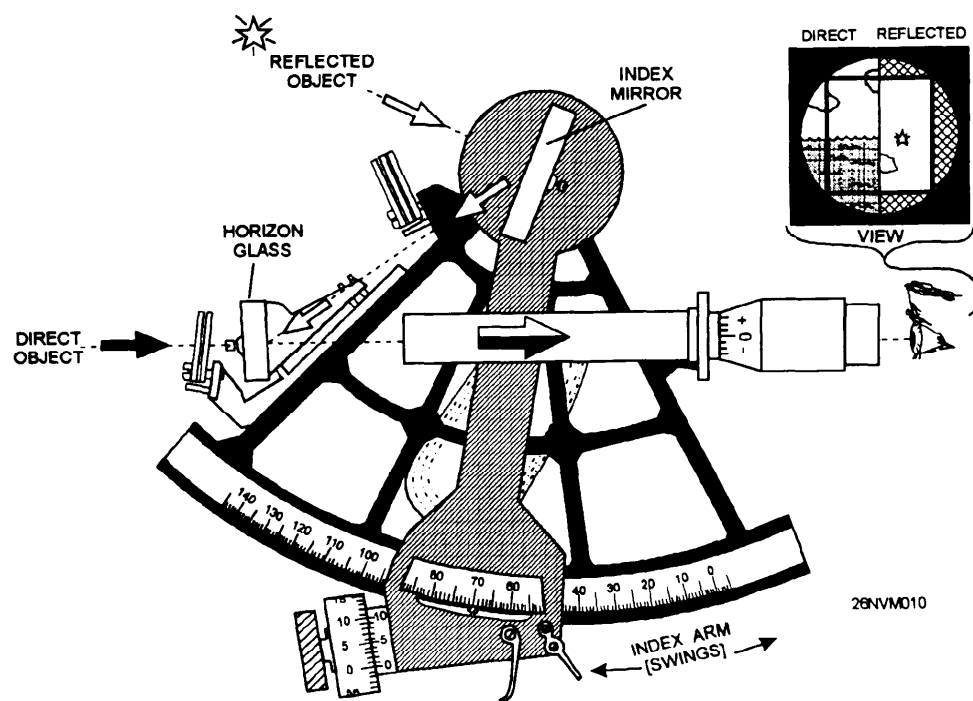

Figure 8-13. How a sextant works.

# The Marine Sextant, Continued

## How to Read the Sextant

Reading a sextant angle involves properly understanding and interpreting the markings on the arc scale, micrometer drum, and vernier scale.

Follow these steps to properly read a sextant angle:

Step	Action
1.	Locate the position of the index arm mark on the arc scale.
2.	Determine which degrees the mark is between. The lower reading is the amount of whole degrees.
3.	Locate the position of the zero mark on the vernier scale.
4.	Determine which minutes the zero mark is between on the micrometer drum. The lower mark is the amount of whole minutes.
5.	On the vernier scale, determine which graduation mark is most nearly in line with one of the graduation marks on the micrometer drum. This mark indicates the amount of tenths of a minute.  <b>Note:</b> To make sure you select the correct mark, look at the vernier marks on each side of the one that appears to be in line with a drum mark. Both vernier marks will be on the inside of the closest drum marks.

Figure 8-14 is an example of a sextant angle of  $67^{\circ} 40.6'$ .

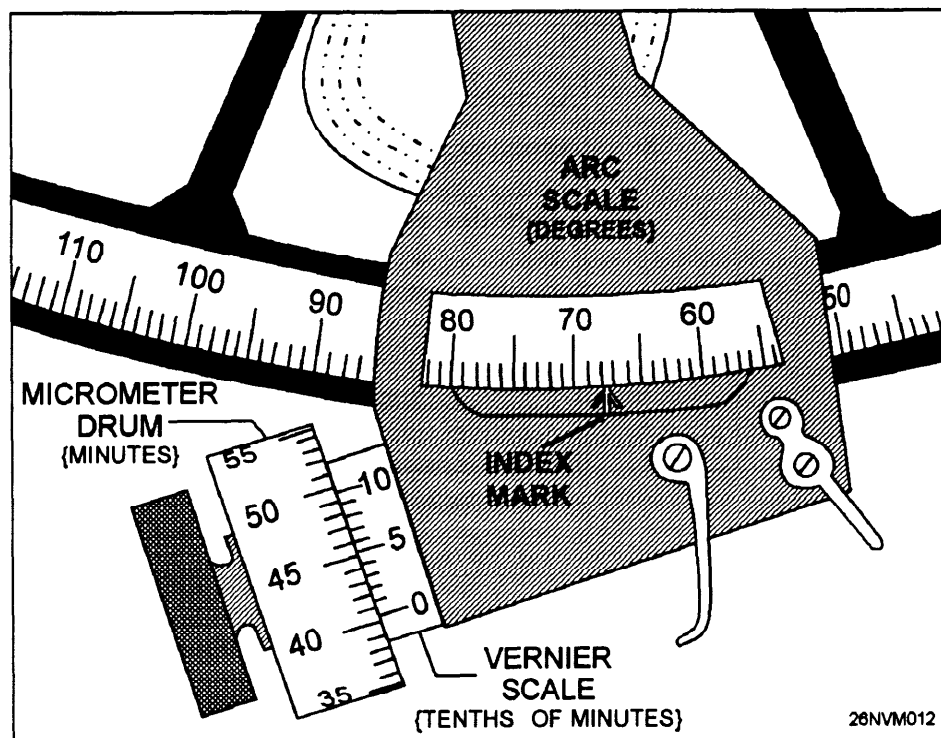

Figure 8-14. Reading a sextant angle.

## The Marine Sextant, Continued

### Finding the Index Error

The marine sextant will measure angles accurately if it is properly adjusted and used correctly. The senior Quartermaster is responsible for making sure that any *adjustable* errors are properly corrected before the sextant is used. However, practically every sextant has a small error called *index error* (IC), which cannot be adjusted.

Use these procedures to determine index error *every time* you use a sextant to measure angles. An *index error correction* must then be applied (added or subtracted) to every angle that is taken.

Follow these steps to determine index error:

Step	Action								
1.	Hold the sextant in a vertical position with your right hand on the handle.								
2.	Move the index arm to approximately zero on the arc scale with your left hand using the release levers.								
3.	View the horizon through the telescope.								
4.	Rotate the micrometer drum to align the reflected image of the horizon with the direct image.								
5.	Take a reading.								
6.	Repeat steps 3 through 5 at least two more times.								
7.	Average the three readings to determine index error.								
8.	Apply the index error correction to your angle. <table border="1"><thead><tr><th>IF index error is...</th><th>THEN...</th></tr></thead><tbody><tr><td>zero</td><td>no correction is needed.</td></tr><tr><td>positive</td><td>subtract the amount of index error.</td></tr><tr><td>negative</td><td>add the index error.</td></tr></tbody></table>	IF index error is...	THEN...	zero	no correction is needed.	positive	subtract the amount of index error.	negative	add the index error.
IF index error is...	THEN...								
zero	no correction is needed.								
positive	subtract the amount of index error.								
negative	add the index error.								



# The Marine Sextant, Continued

## View of the Horizon

Figure 8-15 is an illustration of what you should see when trying to determine index error.

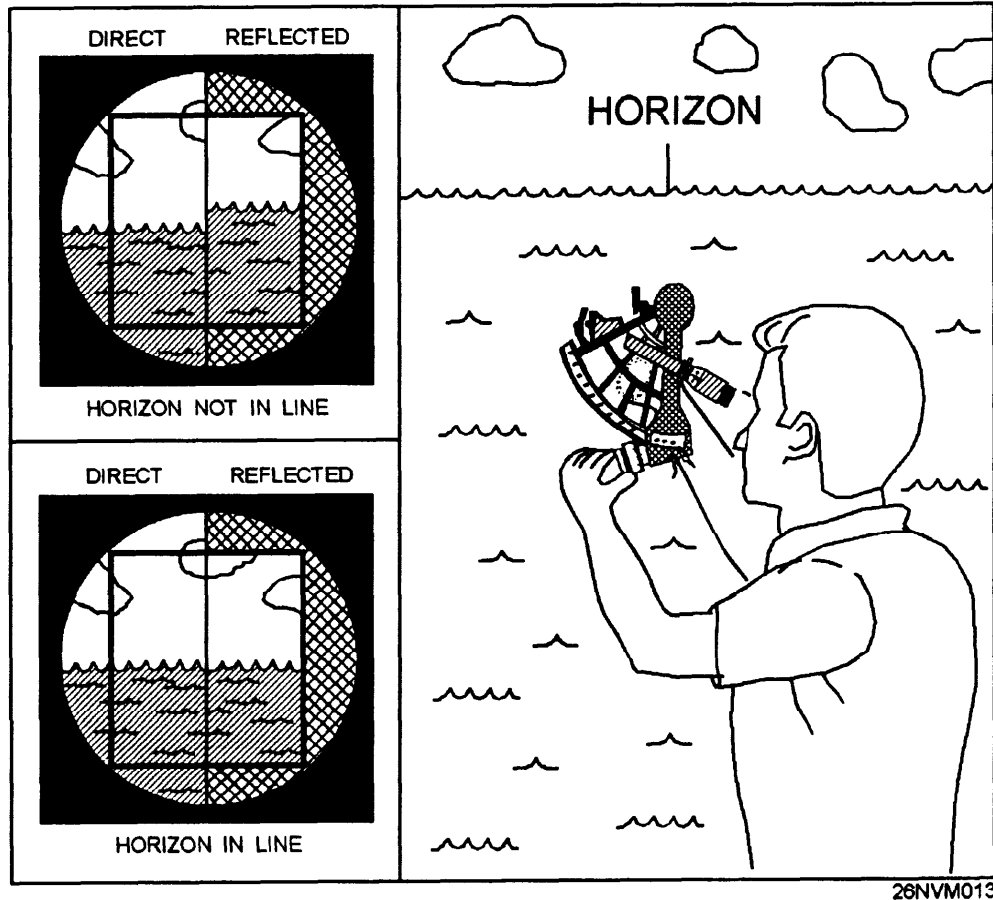

26NVM013

Figure 8-15. Direct and reflected views of the horizon.

## The Marine Sextant, Continued

### How a Reading of 0.0 Index Error Looks

An example of what the scales would look like if there were *no index error* is shown in figure 8-16. Notice that the index mark is directly under the 0 on the arc scale and the 0 mark on the vernier scale lines up directly with the 0 mark on the micrometer drum.

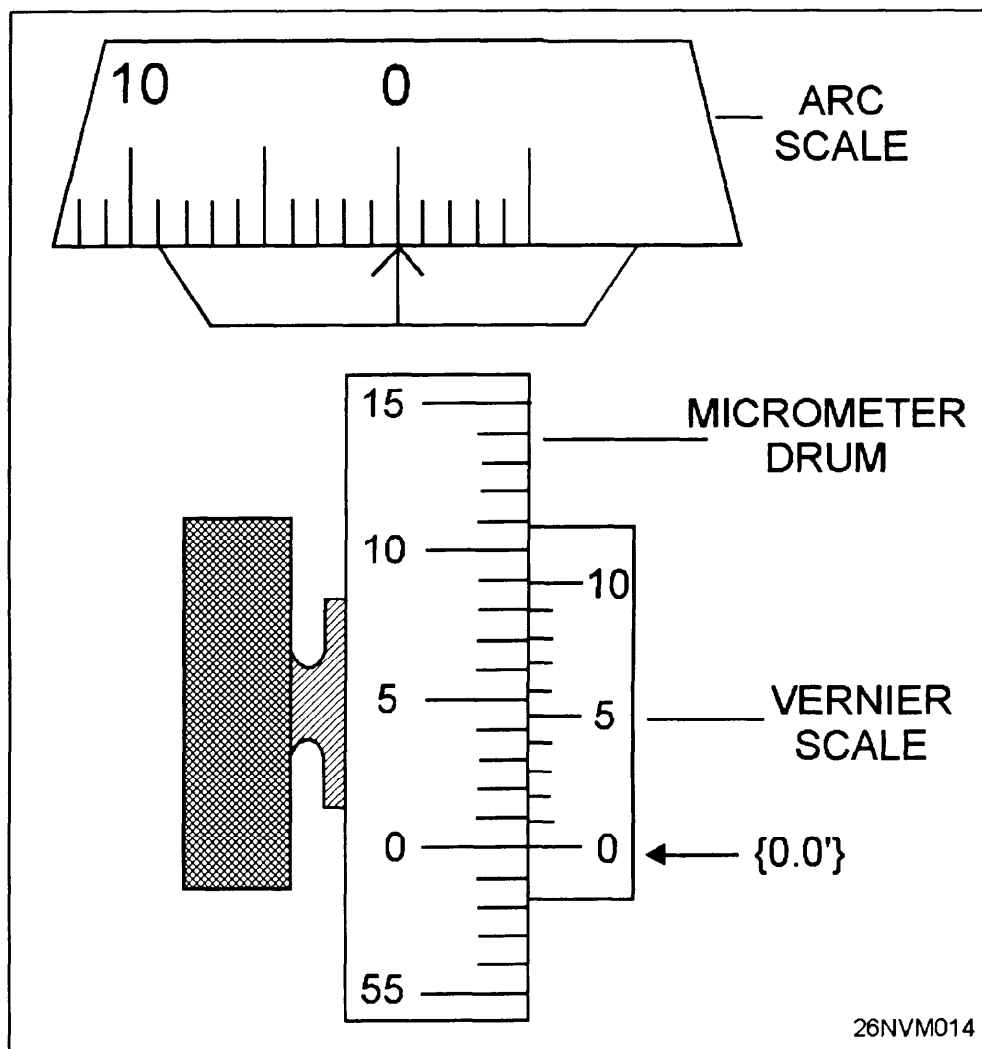

Figure 8-16. A reading of 0.0 index error.

## The Marine Sextant, Continued

### Reading Positive Index Error

An example of what the scales would look like if you had a *positive index error* is shown in figure 8-17. Notice that the index mark is to the left of the 0 on the arc scale and that the 0 on the vernier scale is above the 0 on the micrometer drum, indicating a positive error. The micrometer and vernier scale lineup directly at the 0.4' line on the vernier scale, indicating an index error of +0.4'. This would be *subtracted* from any angles taken with this sextant to obtain an accurate angle.

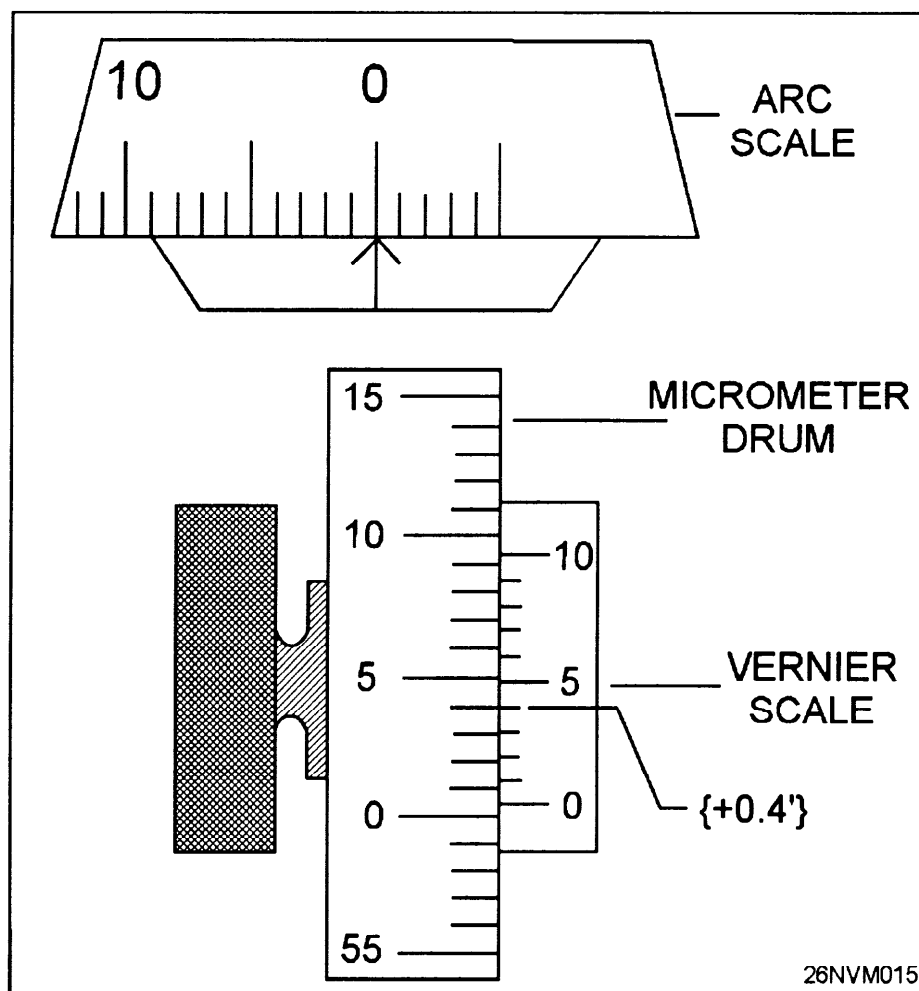

Figure 8-17. Positive index error.

## The Marine Sextant, Continued

### Reading Negative Index Error

An example of a reading of negative index error is shown in figure 8-18. Notice that the index mark is to the right of the 0 on the arc scale and the 0 on the vernier scale is below the 0 on the micrometer drum. The micrometer scale and vernier scale line up directly on the 0.7' mark of the vernier scale, indicating a  $-0.7'$  index error. The correction would be added to any angles shot with the sextant.

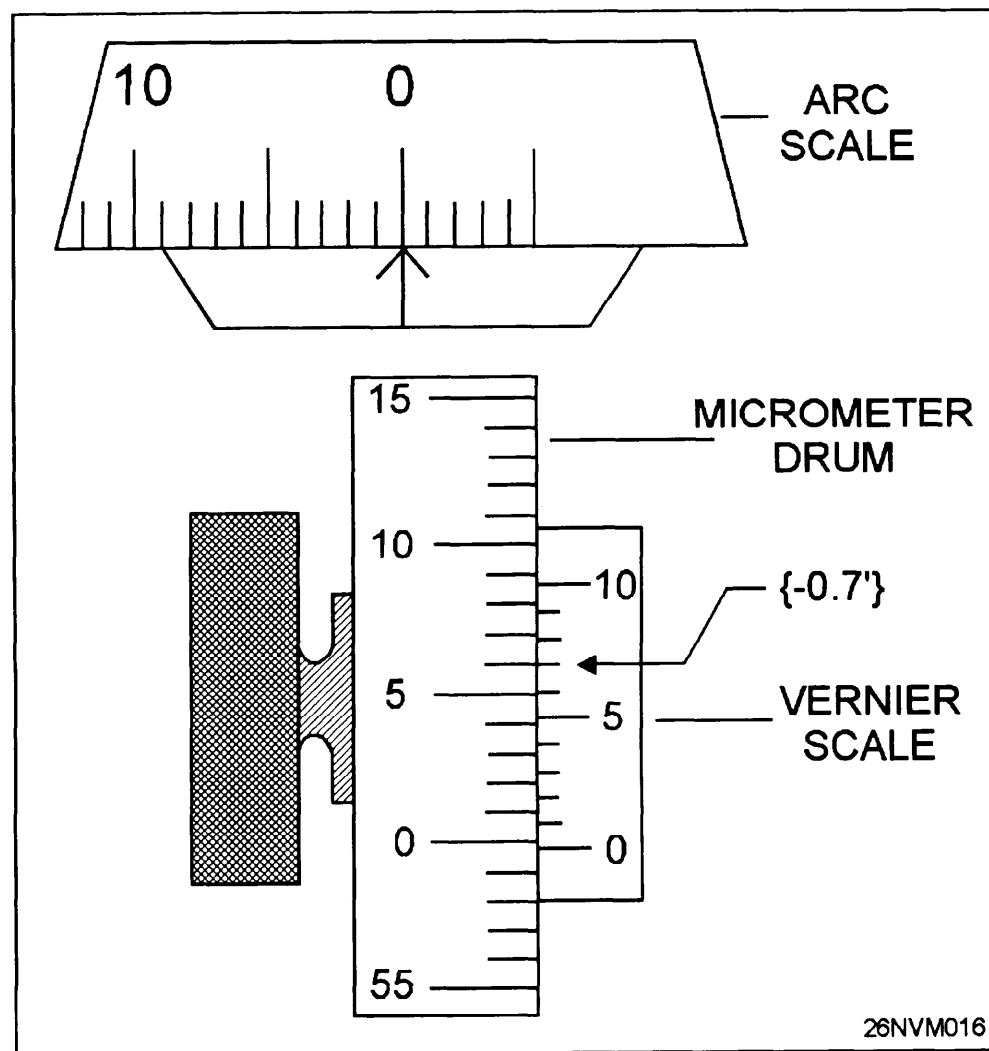

Figure 8-18. Negative index error.

# Determining the Ship's Position Using Sextant Angles

---

## Accuracy and Usage

Horizontal sextant angles give fixes of great accuracy that are not affected by any error of the compass. A fix by horizontal sextant angles is labeled the same as a visual fix with a small circle around the position and the time of the fix close to the fix symbol.

Horizontal sextant angles used in conjunction with a computer-assisted positioning program are the most common method used by the Coast Guard to position aids to navigation.

Horizontal sextant angles should be taken as nearly simultaneously as possible, preferably by two people on a predetermined signal. However, one person can obtain both angles if the ship is not moving quickly.

---

## Procedure

**Rule:** To obtain a fix using sextant angles, you must have *three fixed visual objects*, and those objects must be identifiable on the chart.

Follow these steps to obtain horizontal sextant angles:

Step	Action
1.	Hold the sextant horizontally with your right hand.
2.	View the left object directly through the telescope.
3.	Release the index arm with your left hand on the release levers and swing the arm so that the index mirror reflects the center object in the horizon glass below the left object.
4.	Rotate the micrometer drum to fine adjust the reflected object in line with the object viewed directly.
5.	Take a reading of the angle.
6.	Do you have two people taking angles?  If yes, both angles are ready to be plotted.  If no, repeat steps 1 through 5 using the center object viewed directly and the right object viewed reflected.

## Determining the Ship's Position Using Sextant Angles, Continued

### Select Three Objects

Figure 8-19 illustrates how three objects are needed to obtain two angles.

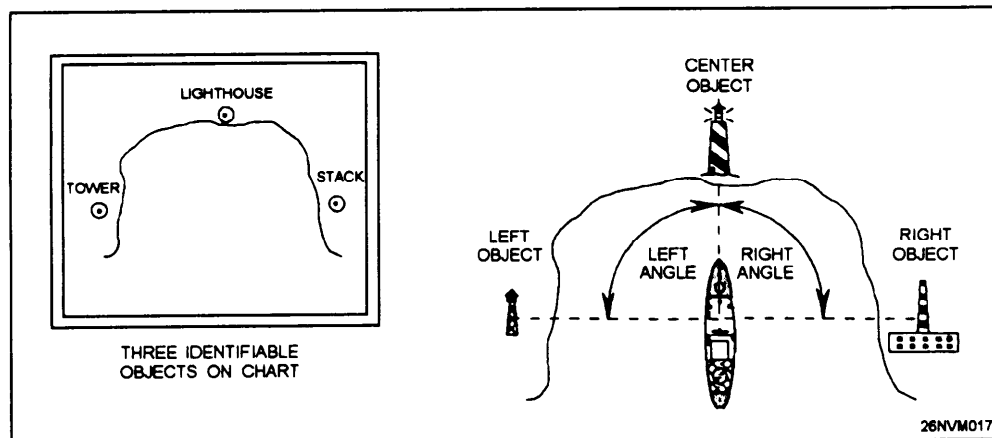

Figure 8-19. Select three objects to obtain two angles.

### View of Two Objects

Figure 8-20 is an illustration of what you see when trying to determine the angle between two objects.

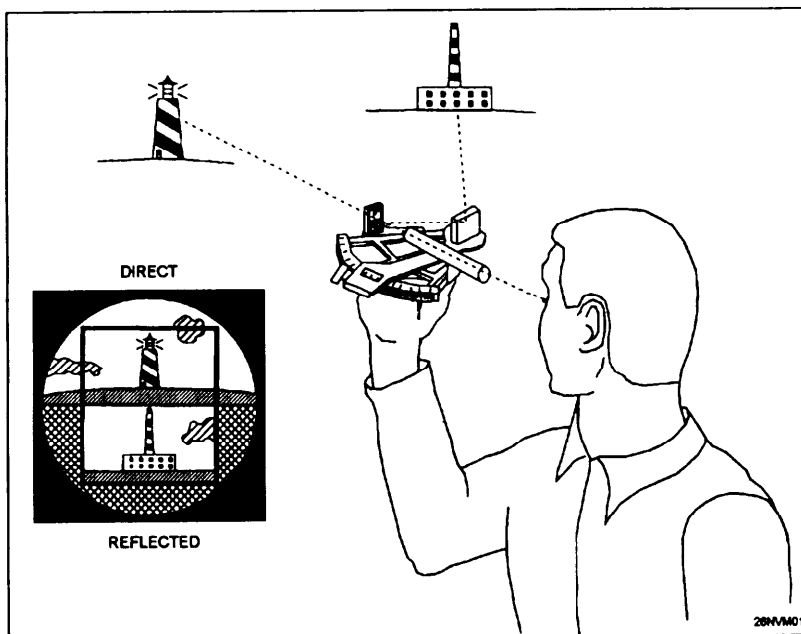

Figure 8-20. Horizontal measurement of two objects.

## Determining the Ship's Position Using Sextant Angles, Continued

### Using the Three-Arm Protractor

The two angles measured are plotted using a three-arm protractor. This instrument, made of brass or plastic, consists of a circular scale that can be read to fractions of a degree or minutes of arc, and to which the three arms are attached. The center, or index arm, is fixed and the zero graduation of the protractor coincides with the straightedge of this arm. The other arms are movable and can be set and locked at any angle relative to the fixed arm. Figure 8-21 is a diagram of a plastic three-arm protractor.

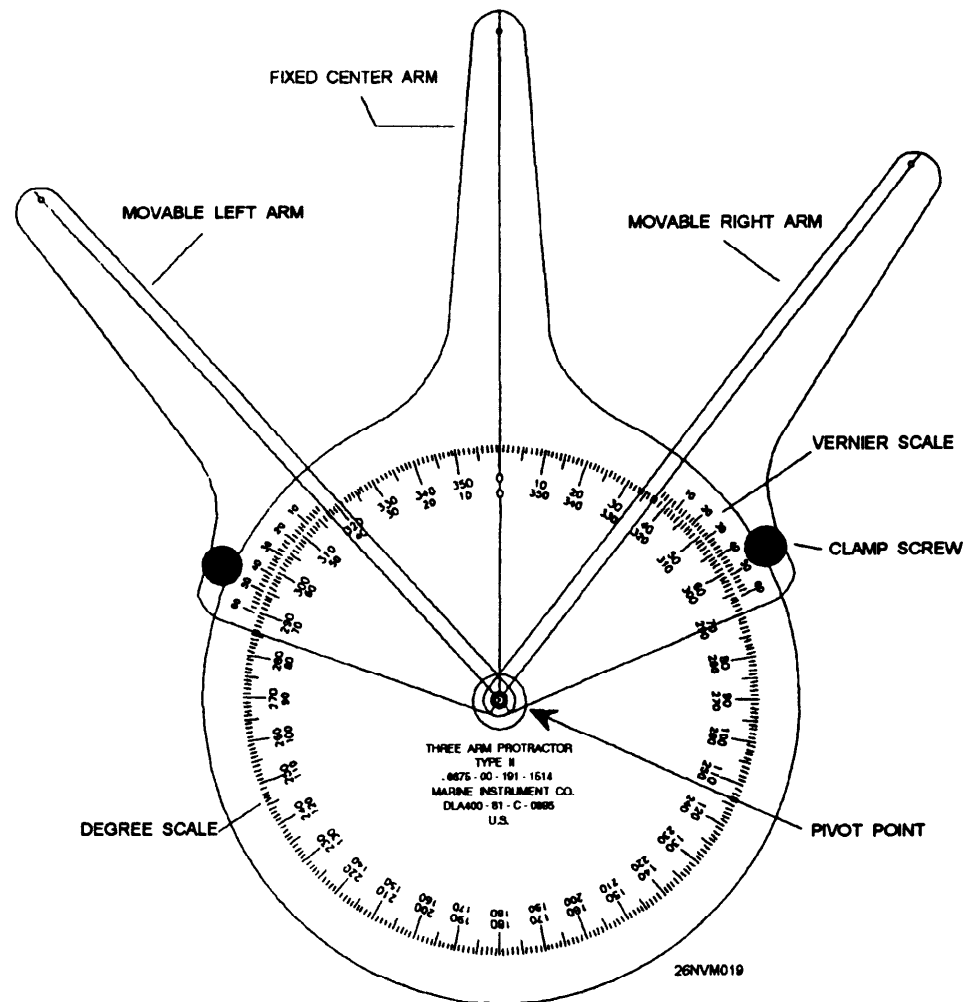

Figure 8-21. Plastic three-arm protractor.

# Determining the Ship's Position Using Sextant Angles, Continued

## Setting the Protractor

The movable arms can be set to the nearest minute of arc using the vernier scale that is inscribed on the movable arms. Use the following steps when setting the movable arms to a specific angle. Figure 8-22 is an example of a setting of 12° 18' on the three-arm protractor.

Step	Action
1.	Loosen the clam screw on the arm you are setting.
2.	Move the arm so that the index line is between the degree you want and the next higher degree.
3.	Adjust the arm so that the vernier mark indicating the minutes of arc you want is directly in line with the degree mark closest to it. <b>Note:</b> Make sure you apply the index error correction to angles.
4.	Tighten the clamp screw on the arm.
5.	Repeat steps 1 through 4 on the other arm for the second angle.

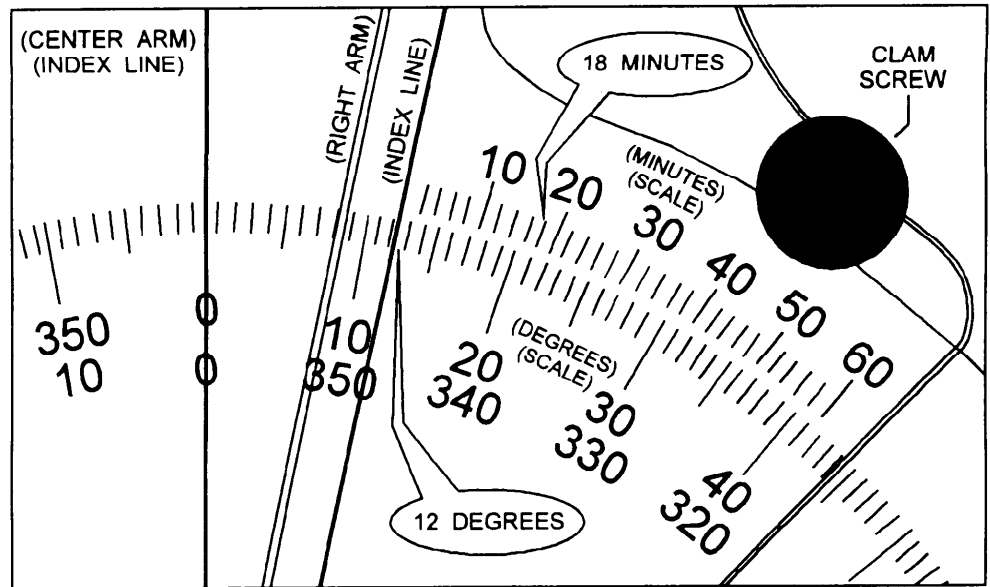

26NVM020

Figure 8-22. Setting angle on the three-arm protractor.



## Determining the Ship's Position Using Sextant Angles, Continued

### Obtaining the Fix

You must first observe the angles with a sextant and set the three-arm protractor with those angles.

### Swingers or Revolvers

If the three objects and the ship all lie on the *circumference of a circle*, the fix is NOT reliable. When this happens, it is called a swinger or revolver and your ship could be anywhere along the circle and still have the same two angles to the three objects. See figure 8-23.

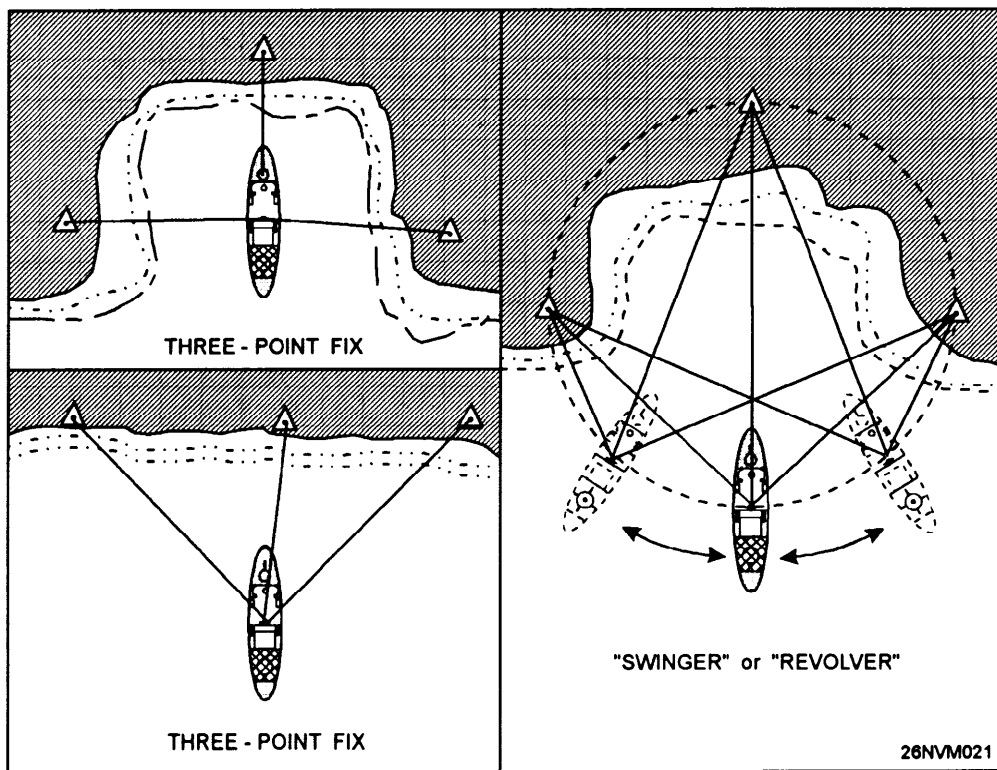

Figure 8-23. Difference between fixes and swingers.

# Determining the Ship's Position Using Sextant Angles, Continued

## Procedure for Plotting the Fix

Use the following steps when you are plotting a position using horizontal sextant angles. Figure 8-24 shows how the protractor is positioned to plot the horizontal sextant angles.

Step	Action
1.	Place the three-arm protractor on the chart.
2.	Position the center (fixed) index line so that it passes through the center object.
3.	Move the protractor slowly across the chart until all three arms are aligned with the three objects.
4.	Mark the ship's position on the chart by inserting a pencil point in the center of the protractor (pivot point).
5.	Check to see that the fix is not a swinger or revolver.

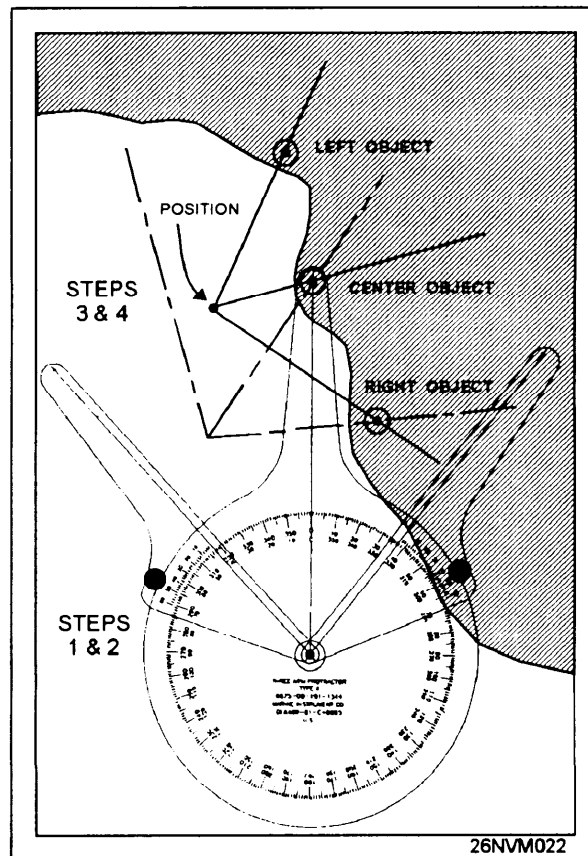

Figure 8-24. Aligning the three-arm protractor.

## Determining the Ship's Position by Running Fix

### The Running Fix

Occasions will arise when it isn't possible to shoot three or more objects to fix the ship's position. In such instances, a single LOP shot on a single object can be advanced to a common time, resulting in a running fix. Advancing a LOP requires nothing more than moving the LOP forward on the same bearing as the ship's course and using the ship's speed without consideration of any current present.

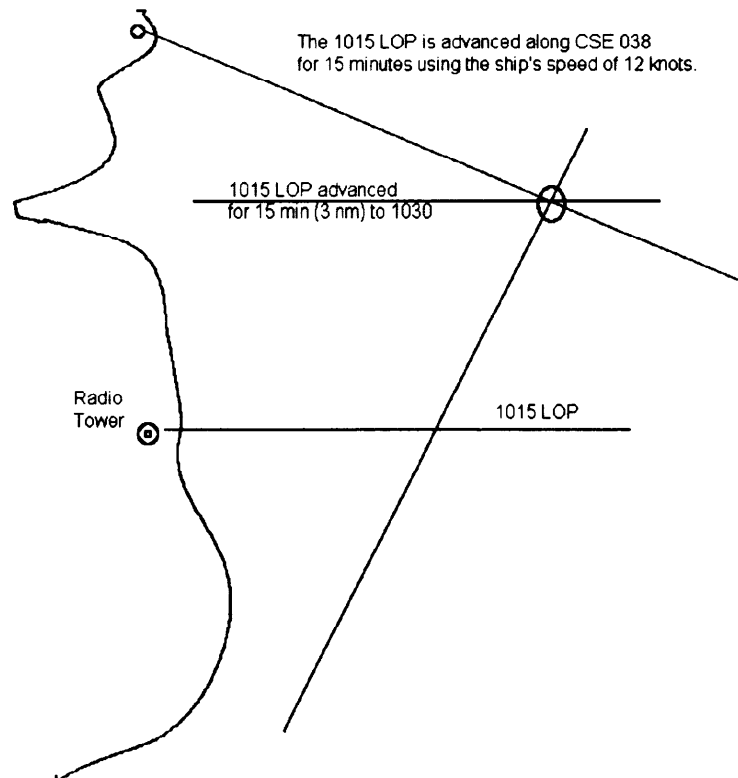

Figure 8-25. Advancing a LOP.

A running fix is labeled in the same manner as a visual fix except that the abbreviation R. fix is put beside the fix and fix time.

Figure 8-25 shows an example of how a LOP is advanced (moved) to obtain a running fix.

# Electronic Navigation

---

## Introduction

Position is determined in electronic navigation in about the same way that it is in piloting, but there is this important difference: the objects used to fix the ship's position need not be visible from the ship. Instead, their bearings (and sometimes their ranges) are obtained electronically.

There are many different types of electronic equipment used in navigation; some of these you may have used, others you may have only heard about. Some of the more important ones are:

- Fathometer
- Radar
- Loran-C
- RDF
- Omega
- SATNAV
- SINS
- GPS

Many people believe that electronic navigation is becoming a primary method for both piloting and long-range navigation. However, you must continually bear in mind that there is no one system that can always be used. Every method has its own limitations, and you should appreciate and understand them. Electronic methods are vulnerable because of the possibility of breakdown, malfunctioning, or damage. They are also subject to atmospheric conditions and some can be successfully blocked by jamming, capture, or destruction of related shore equipment by an opposing force. You must, therefore, have a working knowledge of all navigational methods available to you and be able to use them all as required. Furthermore, the old saying "the equipment is only as accurate as its operators" holds true. And operators are only as accurate as their complete knowledge of the equipment they are using.

---

## Section Objectives

- Describe the procedure used to annotate the fathometer echogram.
- List the components of the fathometer.
- List at least five types of electronic equipment used in navigation.
- List the five steps used to plot time difference lines used occasionally with electronic navigation.
- List the components and operation of satellite navigation systems.

# Using the Fathometer

## Echo-sounding Equipment

Charted landmarks on the ocean floor are often useful in assisting mariners in determining their position. Submarine trenches, canyons, ridges, and seamounts can all be useful in navigation. Echo-sounding equipment such as the Navy AN/UQN-4 is the most common fathometer found on naval vessels. This fathometer is the most accurate for obtaining soundings in shallow depths. The AN/UQN-4 can be set for five different scales. It is equipped with a digital display for reading all scales and it has a strip chart recorder that actually traces the profile of the ocean bottom when reading the 600-foot, 600-fathom, or 6,000-fathom scale. The smallest possible scale should always be used. See figure 8-26.

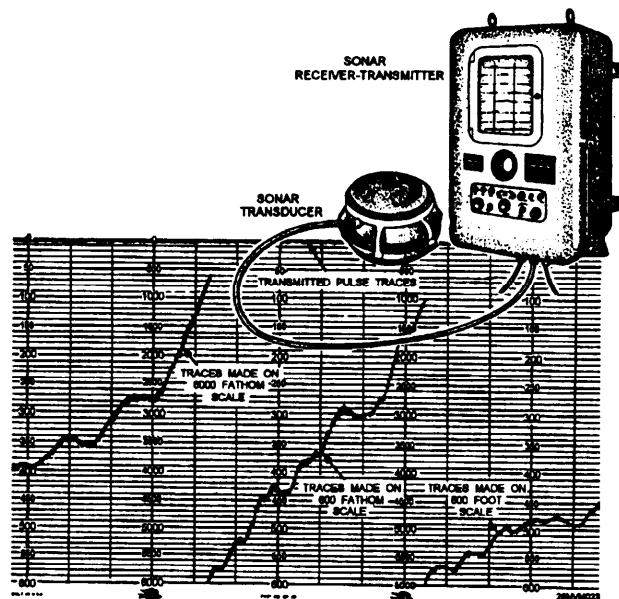

Figure 8-26. Fathometer, transducer, and echogram.

## Annotating the Echogram

The paper on which the depths are recorded is used to annotate the following information at the times indicated:

- The ship's name must be placed at the beginning and at the end of each roll of paper.
- Time in GMT must be marked at the beginning of each watch.
- The current date should be recorded each day at 1200.
- Time and date must also be marked whenever the unit is turned on.

# LORAN-C

---

## Introduction

Loran-C (**L**ong **R**ange Navigation) is an electronic aid to navigation consisting of shore-based radio transmitters. The Loran system enables users to determine their position quickly and accurately day or night in any weather. Your position is determined by locating the crossing point of two lines of position on a Loran-C chart. Most units today will give you a direct readout in latitude and longitude, which will allow you to plot your position even if you do not have a Loran overprinted chart. Loran-C is generally accurate to 1/4 nautical mile. The Loran-C system allows you to determine your position by means of radio signals broadcast by stations of known position. A fix is determined by Loran through the intersection of lines of position obtained by reference to shore stations whose locations are known.

---

## Time Difference Lines

In Loran-C, you locate a LOP by determining the difference in time of arrival of signals sent out by each of a pair of broadcast stations. This interval is constant when the ship is located anywhere along a previously determined Loran-C LOP. To say it another way: When the time interval is a specific amount, the ship must be somewhere on a predetermined Loran-C LOP that is a focus of all points where the interval between arrival of signals is the same.

---

## Plotting Time Difference Lines

Most of the Loran-C receivers in use today provide the user with two displays of fix information. The most commonly used is a readout of the latitude and longitude of the vessel's position. The other is a readout of the time delay of each LOP, which can then be plotted on a Loran-C overprinted chart. The steps for plotting the time difference LOPS are described briefly below:

Step	Action
1.	Examine the Loran-C chart for your area. LOP lines are marked with time difference numbers; chain and secondary identification also appear every few lines.
2.	Read the time difference in the TDA display.
3.	On the chart, locate the line that most closely fits that reading for the secondary selected.
4.	Examine adjacent lines and interpolate to determine where the line that corresponds to your reading is to be plotted
5.	Repeat steps 2 and 3 for the TDB display
6.	Locate the point where the two lines cross and label the fix with a small triangle along with the time affixed close by.

# Satellite Navigation Systems

## SATNAV

The **SAT**ellite **NAV**igation (SATNAV) system is a highly accurate, passive, all-weather, worldwide navigational system suitable for subsurface and surface navigation, as well as for use in aircraft. This system has been in wide use in the fleet, and is also available to commercial interests. Because of today's technology and expertise in transistors, computers, and miniaturization, this system is extremely accurate.

SATNAV plotting is made simple because the receiver gives a written printout of the latitude and longitude of the vessel's position along with other information about the satellite pass which gives the navigator valuable information about the accuracy of that particular satellite pass and the time of the next pass. The AN-SRN-19 (fig. 8-27) is being replaced throughout the fleet by the WRN-6 GPS navigation system. Refer to the SRN-19 operators manual for specific instructions for system setup.

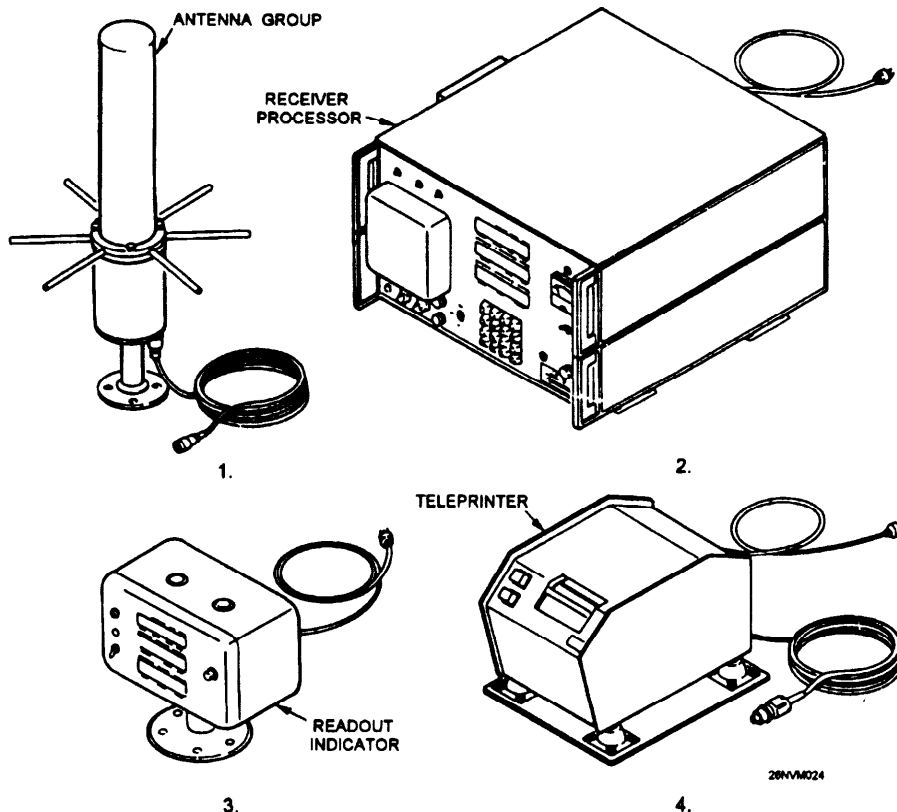

Figure 8-27. AN/MN-19 Satellite Navigation Set.

## Satellite Navigation Systems, Continued

### Navstar GPS

The Navstar **G**lobal **P**ositioning **S**ystem (GPS) was developed to provide highly precise position and time information anywhere in the world, regardless of weather conditions. Now fully operational, GPS consists of 21 satellites (plus 3 operational spares). See figure 8-28. The precise stationing of these satellites will provide worldwide coverage with a minimum of 4 satellites in view of any user.

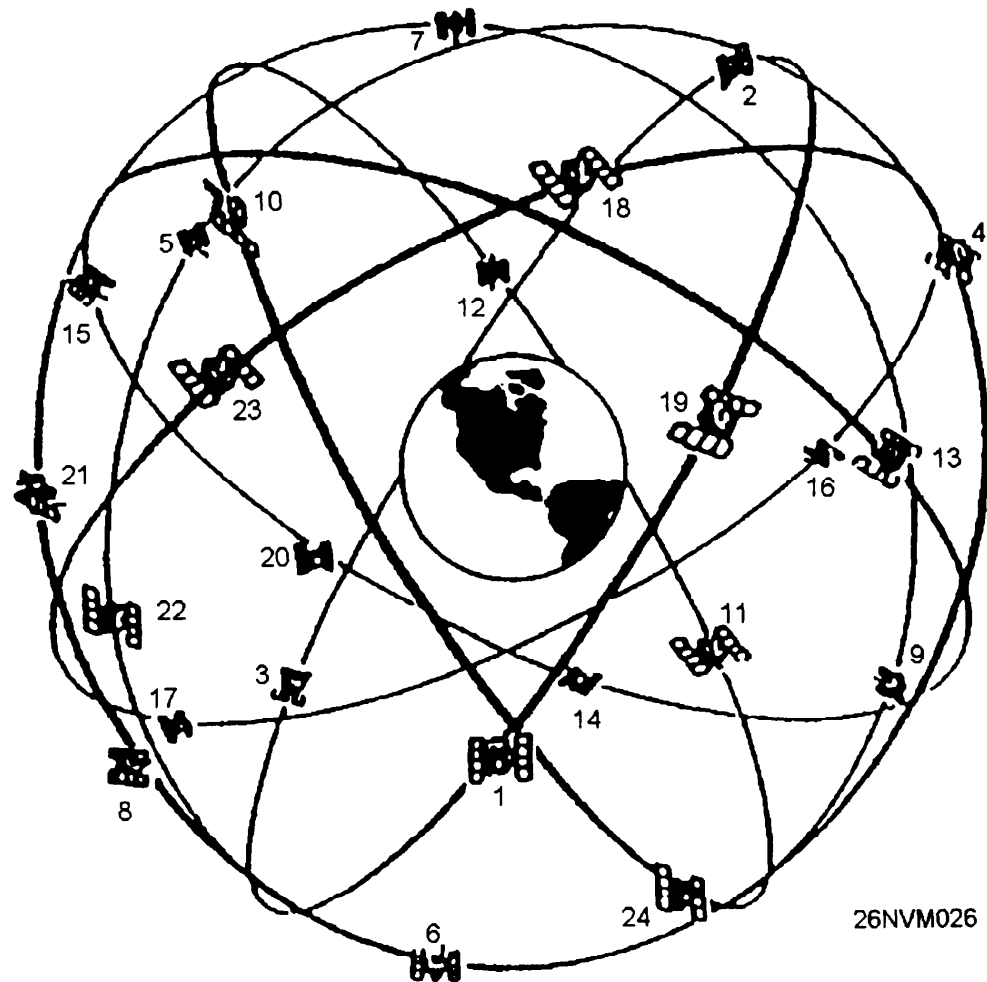

Figure 8-28. Navstar GPS Satellite Constellation.



## Satellite Navigation Systems, Continued

### GPS Signals

Figure 8-29 depicts a simplified view of how a GPS signal is processed. The AN/WRN-6 Satellite Signals Navigation Set is the receiver that the Navy uses to obtain and display GPS fixes.

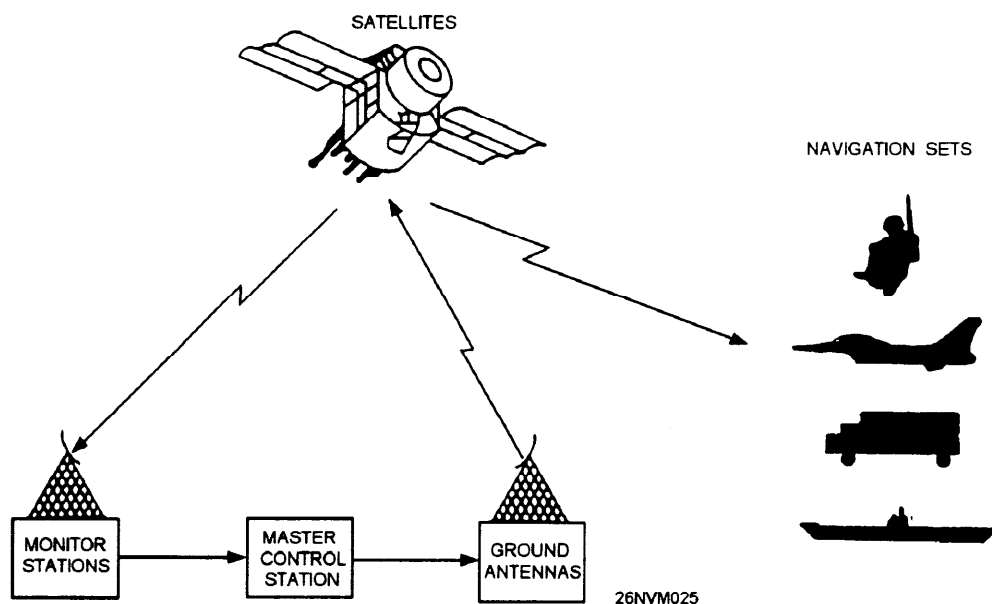

Figure 8-29. Navstar global positioning system.

### AN/WRN 6(V)

The AN/WRN 6(V), shown in figure 8-30, computes accurate position coordinate, elevation, speed, and time information from the signals transmitted from GPS satellites.

**Accuracy:** The AN/WRN 6(V) will provide positions accurate within 100 meters in the unencrypted mode and positions accurate to within 16 meters or less in the encrypted mode. At all times, if possible, the AN/WRN 6(V) should be operated in the encrypted mode.

**Operating Procedures:** Specific operating instructions for the AN/WRN 6(V) are contained in NAVY SPAWAR publication EE170-AA-OMI-020/WRN6. All Quartermasters should become well versed in the contents of this publication.

# Satellite Navigation Systems, Continued

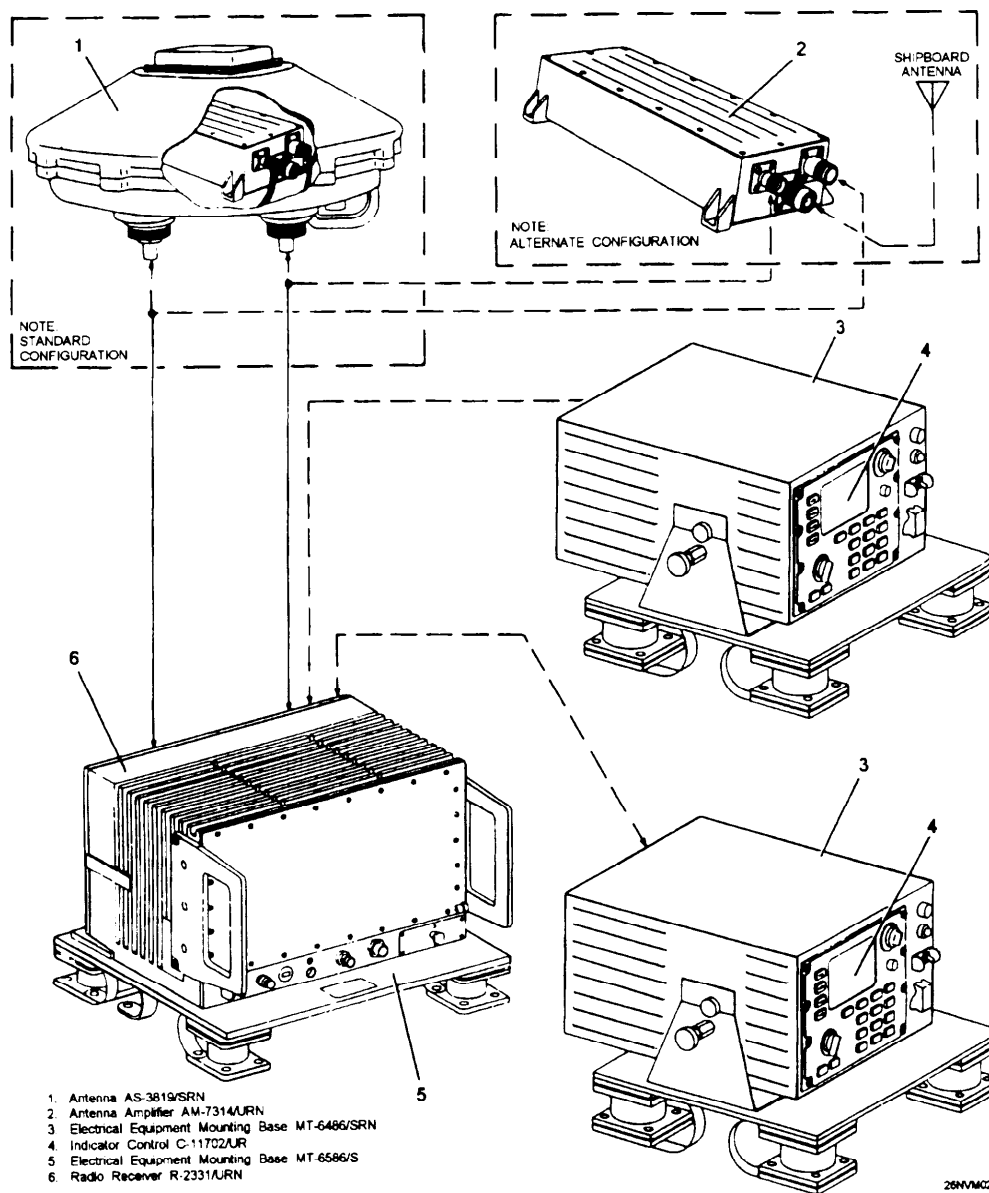

Figure 8-30. Satellite Signals Navigation Set AN/WRN 6(V).

# Navigational Radar







## Components of RADAR

A typical surface radar set is made up of five components.

Component	Description of Function
Transmitter	Sends out electromagnetic waves of energy.
Modulator	Allows waves to be omitted as pulses.
Antenna	Beams the energy at the targets and rotates to scan the surrounding area.
Receiver	Converts the reflected radio energy returned from the target into usable data.
Indicator	Presents the data received visually on a scope.

## How RADAR Works

The following stages help to explain how radar operates:

Stage	Description	Diagram
1	Pulse leaves radar antenna at the speed of light.	
2	Pulse continues through space.	
3	Pulse strikes target.	
4	Echo is returned as original pulse continues.	
5	Echo returned at speed of light.	
6	Echo received by antenna giving indication on scope of presence of other ship.	

26NVM029

## Plan Position Indicator (PPI)

The PPI scope provides a bird's-eye view of the area covered by the radar with your ship in the center. The sweep appears as a bright line and originates in the center of the scope and extends to the outside edge. This straight line sweep is synchronized with the radar antenna and rotates 360°. Each time a target is detected, it appears as an intensified spot on the scope. See figure 8-31.



Figure 8-31. PPI presentation.

---

### **PPI Display Interpretation**

The scope can be adjusted to several different range scales to provide greater target detail. Range is measured in yards or nautical miles from the center of the scope to the target indicated.

Some factors affecting the accuracy of radar are beam width, pulse length, mechanical adjustment, and interpretation. Because of beam width distortion, radar bearings are usually less accurate than radar ranges. A fix obtained where two or more lines of position are determined by ranges is more accurate than one obtained by bearings alone. In most cases, radar ranges will always be available and will be used over radar bearings.

Shorelines appear as they do on the chart; however, the PPI displays a scaled down version of an area of the chart. Determining exactly what you are seeing and where that area is on the chart takes practice.

# How to Obtain a RADAR Bearing and Range

---

## **Bearings**

The PPI is equipped with a *bearing cursor* and a *range strobe*. The bearing cursor, like the sweep, appears as a bright line and can be manually rotated through 360°. Bearing information is obtained by rotating the cursor to the center of the target. The target bearing is then read directly from the bearing dial. On gyro-equipped ships (and most ships having radars are so equipped), the radar has a gyro input and bearings obtained from it are true. If a gyro failure occurs the radar presentation automatically re-orientes to a relative picture and relative bearings may be taken from the PPI.

---

## **Ranges**

The range strobe appears as a bright spot riding on the cursor. As the range crank is turned clockwise, the strobe moves out from the center. Range is obtained by placing the strobe on the leading edge (edge closest to the center of the PPI) of the target. The target range is then read directly from the range dials, either in miles or yards.

---

## **Selecting Objects to Shoot**

When plotting a radar fix, you will have already been comparing your radar "picture" with the navigational chart. Pick out points that show *prominently* on both the chart and the radar. Try to locate reliable targets that are easy to identify. You cannot afford to guess on what you are using to obtain a range from. Objects not permanently fixed to shore or the ocean bottom such as buoys should not be used when obtaining a radar fix. Tangents also should be used as a last resort.

---

## **Shooting Ranges in Proper Order**

The order in which you take your radar ranges is just as important as it was in visual bearings. Take radar ranges ahead and astern first because they are changing most rapidly, then take ranges on or near the beam. As is true with visual fixes, time is a critical element. Work quickly, but accurately.

# How to Plot RADAR Fixes

## Procedure

Use the following steps to properly plot a radar fix. Figure 8-32 is an illustration of what a fix using three radar ranges looks like.

Step	Action
1.	Locate the distance scales or the latitude scale near your approximate location on the chart.
2.	Measure the distance on the scale using a compass.
3.	Locate the charted navigational point used for the range.
4.	Place the sharp point of the compass on the chart where you took the range and draw an arc in the vicinity of your DR position.
5.	Repeat steps 2 thru 4 for all the ranges obtained.
6.	Locate the area where the lines of position (arcs) all cross each other.
7.	Label the radar fix by putting a small triangle around the intersection of the ranges, with the time of the fix noted close to the symbol.

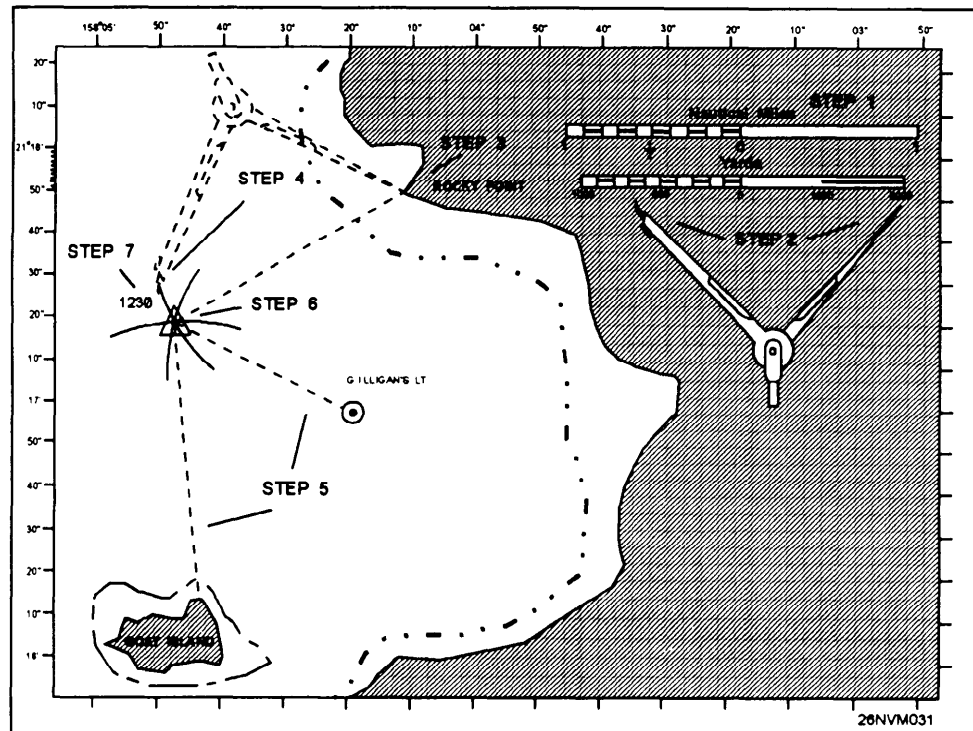

Figure 8-32. Example of a radar fix.

## Other Electronic Navigation Equipment

---

### SINS

SINS (Ship's Inertial Navigation System) is the process of directing the movements of a rocket, ship, aircraft, or other vehicle from one point to another, based on sensing acceleration of the vehicle in a known spatial direction with the aid of instruments that mechanize the Newtonian laws of motion, and integrating acceleration to determine velocity and position.

SINS is an accurate, all-weather, dead reckoning system. It employs gyroscopes, accelerometers, and associated electronics to sense turning rates and accelerations associated with the rotation of the Earth, and with ship's movement relative to the surface of the Earth.

---

### Radio Direction Finders

Radio beacons were the first electronic aid to navigation. The basic value of the radio beacon system lies in its simplicity of operation and its relatively low user costs, even though the results obtained may be somewhat limited. The **R**adio **D**irection **F**inder (RDF) is a specially designed radio receiver equipped with a directional antenna. The antenna is used to determine the direction of the signal emitted by a, shore station, relative to the vessel. A radio beacon is basically a short-range navigational aid, with ranges from 10 to 175 nautical miles. Bearings can be obtained at greater ranges, but they are usually of doubtful accuracy and should be used with caution. When the distance to a radio beacon is greater than 50 miles, a correction is usually applied to the bearing before plotting on a Mercator chart. These corrections, as well as information on the accuracy of bearings, plotting, and other matters, are contained in DMA publication 117, Radio Navigational Aids.





# Chapter 9

## Celestial Observations and Sight Reduction Methods

---

### Introduction

In this chapter you will learn the methods that are necessary to complete a day's work in navigation. These include several ways of finding gyrocompass error, reducing sunlines and moonlines, finding latitude by LAN or Polaris, and reducing sights of stars and planets.

We've already covered the basics of celestial navigation in chapter 6. You may want to occasionally refer back to that material to have a clearer understanding of this material. We will discuss the procedure aspect of performing and reducing celestial observations only. As you become more familiar with this subject, you are advised to increase your knowledge by studying references such as *Dutton's Navigation* and *Piloting* and *Bowditch* Pub No. 9.

---

### Objectives

The material in this chapter will enable the student to:

- Determine gyrocompass error by azimuth of the Sun and Polaris, and amplitude of the Sun.
  - Reduce sights taken on the Sun, Moon, stars, and planets using H.O. 229, *Sight Reduction Tables for Marine Navigation*, and the *Nautical Almanac*.
  - Reduce sights taken on the stars using H.O. 249, *Sight Reduction Tables for Air Navigation* and the *Air Almanac*.
  - Determining latitude by local apparent noon.
  - Plot celestial LOPs based on assumed positions.
- 

Topic	Page
Azimuth of the Sun	9-2
Azimuth by Polaris	9-11
Amplitude of the Sun	9-12
Celestial LOP	9-16
Using the Sextant	9-18
Altitude Corrections	9-19
Reducing Sunlines Using Pub 229	9-24
Plotting LOPs	9-28
Advancing LOPs	9-29
Reducing Sights using Pub 249	9-32
Latitude by LAN	9-36

# Methods For Finding Gyrocompass Error

---

## Introduction

There are three celestial methods used by QMs for finding gyrocompass error. They are:

- Azimuth of the Sun
- Azimuth of Polaris
- Amplitude of the Sun

In each case, you are required to gather data for use in computation. This data may be in the form of sights from the sextant, time in GMT, DR Lat. and Long., and so forth. For each celestial method, we will begin with gathering the necessary data and then working the solutions.

---

## Azimuth of the Sun

**You** must know the following values to determine gyrocompass error by azimuth:

### Gathering Data

- Time of the actual observation
- Date of the observation
- DR position at the time of observation
- Azimuth (gyro bearing of the Sun)

**Rule:** Due to the elevation of the Sun, azimuths should be taken in mid-morning or mid-afternoon.

Use the following table to gather the data to work the azimuth solution. You must have a recorder present to mark and record the exact time of the observation

Step	Action
1.	Obtain a time tick from WRN-6 or chronometer with a stopwatch.
2.	Break out and place the azimuth circle on the gyro repeater closest to the Sun.
3.	Align the Sun in the reflecting mirror in a manner so that the rays reflect back through the prism housing and onto the compass card.
4.	When each spirit level is leveled, mark the time and record the reflected gyro bearing from the compass card to the nearest 0.1°. <b>Note:</b> This is a difficult procedure in heavy seas; however, if the azimuth circle is not level, errors will occur.
5.	Repeat steps 4 and 5 a minimum of three times.

## Azimuth of the Sun, Continued

---

**Gathering Data** Now that we have three good observations, we need only to find the DR position for each observation to have the data we need to find the azimuth of the Sun. We will work an example problem using OPNAV strip form AZIMUTH BY PUB 229. For brevity, we'll work on one observation only. In actual practice, it's faster to work out all three at the same time by placing the strip form on the left and working the three observations in the next three columns. The purpose of taking at least three observations is to allow us to find errors when taking observations and averaging gyro error. This process normally provides the best results in determining total gyro error.

Besides the data from the observation, you'll need the *Nautical Almanac* and Pub 229 to solve the problem.

From the strip form and publication we will find out exactly what the gyro bearing *should* read, then we will compare that value to the actual gyro bearing from the observation. The result will be our gyro error.

---

### **Example Problem**

For our example problem, we will assume that we have gathered the following data:

Date: 19 Nov 84  
DR Lat.: 33° 37' N  
DR Long.: 112° 39' E  
ZT: 15h 42m 22s  
Gyro Brg: 231.6°

On the following pages, you will find the page laid out with the blank strip form on the left, the action steps in the middle, and the result on the right.

## Azimuth of the Sun, Continued

OPNAV 3130/ Azimuth by 229	ACTION	Completed Strip Form
Date:	Enter the date.	19 NOV 84
DR Posit	Enter the DR position.	33°37'N - 112°39'E
Body	Enter the name of the body observed.	Sun
GMT	Enter the time GMT.	07h42m22s
GHA(h)	Enter the GHA hour value from the <i>Nautical Almanac</i> (fig. 9-1)	288° 38.9'
Increment (m/s)	Enter the minutes and seconds value from the <i>Nautical Almanac</i> (fig. 9-2).	10° 35.5'
Total GHA	Add GHA(h) and increments (m/s).	299° 14.4'
DR Long +E, -W (+ - 360° if needed)	Enter the DR Longitude, add east or subtract west.	112° 39.0'E
LHA	LHA= Total GHA +E or -W DR Long.	51° 53.4'
Tab Dec	Enter the tabulated declination for 07 hours on the Sun column from the <i>Nautical Almanac</i> .	S 19° 31.2'
d# / D Corr <sup>n</sup>	<p>The d# is found at the bottom of the Sun Dec column, in this case it is +0.6. It is assigned a + because Dec is increasing (0700= 19°31.2 0800= 19°31.8). You MUST assign a + or - to the d#.</p> <p>The D corr is found on the Increments and Corrections page for 42m 22s. Look under the <i>v</i> or <i>d</i> column for the d# (0.6) and record the Corr<sup>n</sup> value (0.4). The D Corr<sup>n</sup> assumes the same sign as the d# .</p>	+0.6 / +0.4
True Dec	Apply the D Corr <sup>n</sup> to Tab Dec	S 19° 31.6
DR Lat same or contrary	Enter the whole degree of latitude and determine if it is named (N or S) as True Dec In this case, Lat. is N and Dec is S. so it is contrary.	N 33° contrary

Up to this point, we have worked the strip form to obtain three values, LHA, True Dec., and DR Latitude. We now have everything we need to enter Pub 229. Pub 229 is entered using whole degrees of Lat., LHA, and Dec. only. We will also interpolate the leftover values using Pub 229.

# Azimuth of the Sun, Continued

1984 NOVEMBER 17, 18, 19 (SAT., SUN., MON.)

225

G.M.T.	SUN				MOON				Lat.	Twilight			Sunrise	Moonrise			
	G.H.A.	Dec.	G.H.A.	U	Dec.	d	H.P.	Naut.		Civil	17	18		19	20		
																h	m
17 00	183 46.2	S18 58.5	258 20.6	9 9	N14 55.5	13.4	59.0	N 72	07 11	08 49	■	23 36	26 02	02 02	04 25		
01	198 46.1	59.1	272 49.5	9 9	14 42.1	13.5	59.1	N 70	06 59	08 24	10 12	23 51	26 05	02 05	04 17		
02	213 46.0	18 59.7	287 18.4	10 0	14 28.6	13.4	59.1	68	06 50	08 04	09 28	24 03	00 03	02 07	04 11		
03	228 45.8	19 00.3	301 47.4	10 0	14 15.0	13.4	59.1	66	06 42	07 49	08 59	24 13	00 13	02 09	04 06		
04	243 45.7	00.9	316 16.4	10.1	14 01.4	13.7	59.1	64	06 35	07 36	08 37	24 21	00 21	02 11	04 02		
05	258 45.6	01.6	330 45.5	10.0	13 47.7	13.9	59.2	62	06 29	07 25	08 20	24 28	00 28	02 13	03 58		
06	273 45.5	S19 02.2	345 14.5	10.2	N13 33.8	13.9	59.2	60	06 23	07 16	08 06	24 34	00 34	02 14	03 55		
07	288 45.4	02.8	359 43.7	10.1	13 19.9	14.0	59.2	N 58	06 18	07 07	07 54	24 39	00 39	02 15	03 52		
S 08	303 45.2	03.4	14 12.8	10.2	13 05.9	14.1	59.2	56	06 14	07 00	07 43	24 44	00 44	02 16	03 50		
A 09	318 45.1	04.0	28 42.0	10.2	12 51.8	14.1	59.3	54	06 10	06 53	07 34	24 48	00 48	02 17	03 48		
T 10	333 45.0	04.6	43 11.2	10.3	12 37.7	14.3	59.3	52	06 06	06 47	07 25	24 52	00 52	02 18	03 46		
U 11	348 44.8	05.2	57 40.5	10.3	12 23.4	14.3	59.3	50	06 02	06 42	07 18	24 55	00 55	02 19	03 44		
R 12	3 44.7	S19 05.8	72 09.8	10.3	N12 09.1	14.4	59.3	45	05 54	06 30	07 02	25 03	01 03	02 21	03 40		
D 13	18 44.6	06.4	86 39.1	10.3	11 54.7	14.5	59.3	N 40	05 47	06 19	06 49	25 09	01 09	02 22	03 37		
O 14	33 44.5	07.0	101 08.4	10.4	11 40.2	14.5	59.4	35	05 40	06 10	06 37	00 05	01 14	02 23	03 34		
A 15	48 44.3	07.6	115 37.8	10.4	11 25.7	14.6	59.4	30	05 33	06 02	06 28	00 12	01 18	02 25	03 31		
Y 16	63 44.2	08.2	130 07.2	10.5	11 11.1	14.7	59.4	20	05 21	05 47	06 11	00 26	01 26	02 26	03 27		
17	78 44.1	08.8	144 36.7	10.5	10 56.4	14.8	59.4	N 10	05 08	05 34	05 56	00 38	01 33	02 28	03 23		
18	93 44.0	S19 09.4	159 06.2	10.5	N10 41.6	14.8	59.5	0	04 54	05 20	05 42	00 49	01 40	02 30	03 20		
19	108 43.8	10.0	173 35.7	10.5	10 26.8	14.9	59.5	S 10	04 39	05 05	05 27	01 00	01 46	02 31	03 17		
20	123 43.7	10.6	188 05.2	10.5	10 11.9	15.0	59.5	20	04 20	04 48	05 12	01 12	01 53	02 33	03 13		
21	138 43.6	11.2	202 34.7	10.6	9 56.9	15.0	59.5	30	03 57	04 28	04 54	01 25	02 01	02 35	03 09		
22	153 43.4	11.8	217 04.3	10.6	9 41.9	15.1	59.5	35	03 42	04 16	04 44	01 33	02 05	02 36	03 07		
23	168 43.3	12.4	231 33.9	10.6	9 26.8	15.2	59.6	40	03 23	04 01	04 32	01 41	02 10	02 38	03 05		
18 00	183 43.2	S19 13.0	246 03.5	10.7	N 9 11.6	15.2	59.6	45	03 00	03 44	04 18	01 51	02 16	02 39	03 02		
01	198 43.0	13.6	260 33.2	10.6	8 56.4	15.3	59.6	S 50	02 28	03 21	04 01	02 04	02 23	02 41	02 58		
02	213 42.9	14.2	275 02.8	10.7	8 41.1	15.4	59.6	52	02 11	03 10	03 52	02 09	02 26	02 42	02 57		
03	228 42.8	14.8	289 32.5	10.7	8 25.7	15.4	59.7	54	01 50	02 57	03 43	02 15	02 30	02 42	02 55		
04	243 42.6	15.4	304 02.2	10.7	8 10.3	15.4	59.7	56	01 23	02 42	03 33	02 22	02 34	02 43	02 53		
05	258 42.5	16.0	318 31.9	10.7	7 54.9	15.5	59.7	58	00 38	02 25	03 21	02 30	02 38	02 45	02 51		
06	273 42.4	S19 16.6	333 01.6	10.8	N 7 39.4	15.6	59.7	S 60	///	02 02	03 07	02 39	02 43	02 46	02 49		
07	288 42.2	17.2	347 31.4	10.8	7 23.8	15.6	59.7										
08	303 42.1	17.8	2 01.2	10.7	7 08.2	15.7	59.8										
S 09	318 42.0	18.3	16 30.9	10.8	6 52.5	15.7	59.8										
U 10	333 41.8	18.9	31 00.7	10.8	6 36.8	15.7	59.8										
N 11	348 41.7	19.5	45 30.5	10.8	6 21.1	15.8	59.8										
D 12	3 41.6	S19 20.1	60 00.3	10.9	N 6 05.3	15.9	59.8	N 72	■	14 40	16 19	15 47	15 10	14 38	14 04		
A 13	18 41.4	20.7	74 30.2	10.8	5 49.4	15.9	59.9	N 70	13 18	15 06	16 30	15 30	15 03	14 39	14 15		
Y 14	33 41.3	21.3	89 00.0	10.8	5 33.5	15.9	59.9	68	14 02	15 25	16 40	15 15	14 57	14 41	14 24		
15	48 41.2	21.9	103 29.8	10.9	5 17.6	16.0	59.9	66	14 30	15 41	16 48	15 04	14 52	14 42	14 31		
16	63 41.0	22.5	117 59.7	10.8	5 01.6	16.0	59.9	64	14 52	15 54	16 55	14 54	14 48	14 43	14 37		
17	78 40.9	23.1	132 29.5	10.9	4 45.6	16.0	59.9	62	15 10	16 05	17 01	14 45	14 45	14 44	14 43		
18	93 40.7	S19 23.6	146 59.4	10.8	N 4 29.6	16.1	59.9	60	15 24	16 14	17 06	14 38	14 42	14 45	14 48		
19	108 40.6	24.2	161 29.2	10.9	4 13.5	16.1	60.0	N 58	15 36	16 22	17 11	14 32	14 39	14 45	14 52		
20	123 40.5	24.8	175 59.1	10.8	3 57.4	16.2	60.0	56	15 47	16 30	17 16	14 26	14 36	14 46	14 56		
21	138 40.3	25.4	190 28.9	10.9	3 41.2	16.2	60.0	54	15 56	16 36	17 20	14 21	14 34	14 46	14 59		
22	153 40.2	26.0	204 58.8	10.8	3 25.0	16.2	60.0	52	16 05	16 43	17 24	14 16	14 32	14 47	15 02		
23	168 40.1	26.6	219 28.6	10.8	3 08.8	16.2	60.0	50	16 12	16 48	17 28	14 12	14 30	14 47	15 05		
19 00	183 39.9	S19 27.2	233 58.4	10.9	N 2 52.6	16.2	60.0	45	16 28	17 00	17 36	14 02	14 26	14 48	15 12		
01	198 39.8	27.7	248 28.3	10.8	2 36.4	16.3	60.1	N 40	16 41	17 11	17 44	13 54	14 22	14 49	15 17		
02	213 39.6	28.3	262 58.1	10.9	2 20.1	16.3	60.1	35	16 53	17 20	17 50	13 48	14 19	14 50	15 21		
03	228 39.5	28.9	277 28.0	10.8	2 03.8	16.3	60.1	30	17 03	17 28	17 57	13 42	14 17	14 51	15 25		
04	243 39.3	29.5	291 57.8	10.8	1 47.5	16.4	60.1	20	17 20	17 43	18 10	13 31	14 12	14 52	15 32		
05	258 39.2	30.1	306 27.6	10.8	1 31.1	16.3	60.1	N 10	17 35	17 57	18 23	13 22	14 08	14 53	15 39		
06	273 39.1	S19 30.6	320 57.4	10.8	N 1 14.8	16.4	60.1	0	17 49	18 11	18 36	13 13	14 03	14 53	15 44		
07	288 38.9	31.2	335 27.2	10.8	0 58.4	16.4	60.2	S 10	18 03	18 26	18 52	13 04	13 59	14 54	15 50		
08	303 38.8	31.8	349 57.0	10.7	0 42.0	16.4	60.2	20	18 19	18 42	19 10	12 55	13 55	14 55	15 56		
09	318 38.6	32.4	4 26.7	10.8	0 25.6	16.4	60.2	30	18 36	19 03	19 34	12 44	13 50	14 56	16 04		
M 10	333 38.5	32.9	18 56.5	10.7	M 0 9.2	16.4	60.2	35	18 47	19 15	19 50	12 38	13 47	14 57	16 08		
N 11	348 38.3	33.5	33 26.2	10.7	S 0 7.2	16.5	60.2	40	18 59	19 30	20 08	12 30	13 44	14 57	16 12		
D 12	3 38.2	S19 34.1	47 55.9	10.7	S 0 23.7	16.4	60.2	45	19 13	19 48	20 32	12 22	13 40	14 58	16 18		
A 13	18 38.1	34.7	62 25.6	10.7	0 40.1	16.4	60.2	S 50	19 31	20 11	21 04	12 11	13 35	14 59	16 24		
Y 14	33 37.9	35.2	76 55.3	10.7	0 56.5	16.5	60.2	52	19 39	20 22	21 22	12 07	13 33	14 59	16 27		
15	48 37.8	35.8	91 25.0	10.6	1 13.0	16.4	60.3	54	19 48	20 35	21 43	12 01	13 30	15 00	16 31		
16	63 37.6	36.4	105 54.6	10.6	1 29.4	16.5	60.3	56	19 59	20 50	22 12	11 55	13 28	15 00	16 35		
17	78 37.5	37.0	120 24.2	10.6	1 45.9	16.4	60.3	58	20 11	21 08	23 01	11 49	13 25	15 01	16 39		
18	93 37.3	S19 37.5	134 53.8	10.6	S 2 02.3	16.4	60.3	S 60	20 25	21 31	///	11 41	13 21	15 02			

# Azimuth of the Sun, Continued

42 <sup>m</sup>		INCREMENTS AND CORRECTIONS									43 <sup>m</sup>									
42 <sup>m</sup>	SUN PLANETS	ARIES	MOON	$\frac{v}{d}$	$\frac{v}{d}$	$\frac{v}{d}$	$\frac{v}{d}$	$\frac{v}{d}$	$\frac{v}{d}$	$\frac{v}{d}$	43 <sup>m</sup>	SUN PLANETS	ARIES	MOON	$\frac{v}{d}$	$\frac{v}{d}$	$\frac{v}{d}$			
00	10 300	10 31.7	10 01.3	0.0	0.0	6.0	4.3	12.0	8.5	0.0	0.0	10 450	10 46.8	10 15.6	0.0	0.0	6.0	4.4	12.0	8.7
01	10 30.3	10 32.0	10 01.5	0.1	0.1	6.1	4.3	12.1	8.6	0.1	0.1	10 45.3	10 47.0	10 15.9	0.1	0.1	6.1	4.4	12.1	8.8
02	10 30.5	10 32.2	10 01.8	0.2	0.1	6.2	4.4	12.2	8.6	0.2	0.1	10 45.5	10 47.3	10 16.1	0.2	0.1	6.2	4.5	12.2	8.8
03	10 30.8	10 32.5	10 02.0	0.3	0.2	6.3	4.5	12.3	8.7	0.3	0.2	10 45.8	10 47.5	10 16.3	0.3	0.2	6.3	4.6	12.3	8.9
04	10 31.0	10 32.7	10 02.3	0.4	0.3	6.4	4.5	12.4	8.8	0.4	0.3	10 46.0	10 47.8	10 16.6	0.4	0.3	6.4	4.6	12.4	9.0
05	10 31.3	10 33.0	10 02.5	0.5	0.4	6.5	4.6	12.5	8.9	0.5	0.4	10 46.3	10 48.0	10 16.8	0.5	0.4	6.5	4.7	12.5	9.1
06	10 31.5	10 33.2	10 02.7	0.6	0.4	6.6	4.7	12.6	8.9	0.6	0.4	10 46.5	10 48.3	10 17.0	0.6	0.4	6.6	4.8	12.6	9.1
07	10 31.8	10 33.5	10 03.0	0.7	0.5	6.7	4.7	12.7	9.0	0.7	0.5	10 46.8	10 48.5	10 17.3	0.7	0.5	6.7	4.9	12.7	9.2
08	10 32.0	10 33.7	10 03.2	0.8	0.6	6.8	4.8	12.8	9.1	0.8	0.6	10 47.0	10 48.8	10 17.5	0.8	0.6	6.8	4.9	12.8	9.3
09	10 32.3	10 34.0	10 03.4	0.9	0.6	6.9	4.9	12.9	9.1	0.9	0.7	10 47.3	10 49.0	10 17.8	0.9	0.7	6.9	5.0	12.9	9.4
10	10 32.5	10 34.2	10 03.7	1.0	0.7	7.0	5.0	13.0	9.2	1.0	0.7	10 47.5	10 49.3	10 18.0	1.0	0.7	7.0	5.1	13.0	9.4
11	10 32.8	10 34.5	10 03.9	1.1	0.8	7.1	5.0	13.1	9.3	1.1	0.8	10 47.8	10 49.5	10 18.2	1.1	0.8	7.1	5.1	13.1	9.5
12	10 33.0	10 34.7	10 04.2	1.2	0.9	7.2	5.1	13.2	9.4	1.2	0.9	10 48.0	10 49.8	10 18.5	1.2	0.9	7.2	5.2	13.2	9.6
13	10 33.3	10 35.0	10 04.4	1.3	0.9	7.3	5.2	13.3	9.4	1.3	0.9	10 48.3	10 50.0	10 18.7	1.3	0.9	7.3	5.3	13.3	9.6
14	10 33.5	10 35.2	10 04.6	1.4	1.0	7.4	5.2	13.4	9.5	1.4	1.0	10 48.5	10 50.3	10 19.0	1.4	1.0	7.4	5.4	13.4	9.7
15	10 33.8	10 35.5	10 04.9	1.5	1.1	7.5	5.3	13.5	9.6	1.5	1.1	10 48.8	10 50.5	10 19.2	1.5	1.1	7.5	5.4	13.5	9.8
16	10 34.0	10 35.7	10 05.1	1.6	1.1	7.6	5.4	13.6	9.6	1.6	1.2	10 49.0	10 50.8	10 19.4	1.6	1.2	7.6	5.5	13.6	9.9
17	10 34.3	10 36.0	10 05.4	1.7	1.2	7.7	5.5	13.7	9.7	1.7	1.2	10 49.3	10 51.0	10 19.7	1.7	1.2	7.7	5.6	13.7	9.9
18	10 34.5	10 36.2	10 05.6	1.8	1.3	7.8	5.5	13.8	9.8	1.8	1.3	10 49.5	10 51.3	10 19.9	1.8	1.3	7.8	5.7	13.8	10.0
19	10 34.8	10 36.5	10 05.8	1.9	1.3	7.9	5.6	13.9	9.8	1.9	1.4	10 49.8	10 51.5	10 20.2	1.9	1.4	7.9	5.7	13.9	10.1
20	10 35.0	10 36.7	10 06.1	2.0	1.4	8.0	5.7	14.0	9.9	2.0	1.5	10 50.0	10 51.8	10 20.4	2.0	1.5	8.0	5.8	14.0	10.2
21	10 35.3	10 37.0	10 06.3	2.1	1.5	8.1	5.7	14.1	10.0	2.1	1.5	10 50.3	10 52.0	10 20.6	2.1	1.5	8.1	5.9	14.1	10.2
22	10 35.5	10 37.2	10 06.5	2.2	1.6	8.2	5.8	14.2	10.1	2.2	1.6	10 50.5	10 52.3	10 20.9	2.2	1.6	8.2	5.9	14.2	10.3
23	10 35.8	10 37.5	10 06.8	2.3	1.6	8.3	5.9	14.3	10.1	2.3	1.7	10 50.8	10 52.5	10 21.1	2.3	1.7	8.3	6.0	14.3	10.4
24	10 36.0	10 37.7	10 07.0	2.4	1.7	8.4	6.0	14.4	10.2	2.4	1.7	10 51.0	10 52.8	10 21.3	2.4	1.7	8.4	6.1	14.4	10.4
25	10 36.3	10 38.0	10 07.3	2.5	1.8	8.5	6.0	14.5	10.3	2.5	1.8	10 51.3	10 53.0	10 21.6	2.5	1.8	8.5	6.2	14.5	10.5
26	10 36.5	10 38.2	10 07.5	2.6	1.8	8.6	6.1	14.6	10.3	2.6	1.9	10 51.5	10 53.3	10 21.8	2.6	1.9	8.6	6.2	14.6	10.6
27	10 36.8	10 38.5	10 07.7	2.7	1.9	8.7	6.2	14.7	10.4	2.7	2.0	10 51.8	10 53.5	10 22.1	2.7	2.0	8.7	6.3	14.7	10.7
28	10 37.0	10 38.7	10 08.0	2.8	2.0	8.8	6.2	14.8	10.5	2.8	2.0	10 52.0	10 53.8	10 22.3	2.8	2.0	8.8	6.4	14.8	10.7
29	10 37.3	10 39.0	10 08.2	2.9	2.1	8.9	6.3	14.9	10.6	2.9	2.1	10 52.3	10 54.0	10 22.5	2.9	2.1	8.9	6.5	14.9	10.8
30	10 37.5	10 39.2	10 08.5	3.0	2.1	9.0	6.4	15.0	10.6	3.0	2.2	10 52.5	10 54.3	10 22.8	3.0	2.2	9.0	6.5	15.0	10.9
31	10 37.8	10 39.5	10 08.7	3.1	2.2	9.1	6.4	15.1	10.7	3.1	2.2	10 52.8	10 54.5	10 23.0	3.1	2.2	9.1	6.6	15.1	10.9
32	10 38.0	10 39.7	10 08.9	3.2	2.3	9.2	6.5	15.2	10.8	3.2	2.3	10 53.0	10 54.8	10 23.3	3.2	2.3	9.2	6.7	15.2	11.0
33	10 38.3	10 40.0	10 09.2	3.3	2.3	9.3	6.6	15.3	10.8	3.3	2.4	10 53.3	10 55.0	10 23.5	3.3	2.4	9.3	6.7	15.3	11.1
34	10 38.5	10 40.2	10 09.4	3.4	2.4	9.4	6.7	15.4	10.9	3.4	2.5	10 53.5	10 55.3	10 23.7	3.4	2.5	9.4	6.8	15.4	11.2
35	10 38.8	10 40.5	10 09.7	3.5	2.5	9.5	6.7	15.5	11.0	3.5	2.5	10 53.8	10 55.5	10 24.0	3.5	2.5	9.5	6.9	15.5	11.2
36	10 39.0	10 40.7	10 09.9	3.6	2.6	9.6	6.8	15.6	11.1	3.6	2.6	10 54.0	10 55.8	10 24.2	3.6	2.6	9.6	7.0	15.6	11.3
37	10 39.3	10 41.0	10 10.1	3.7	2.6	9.7	6.9	15.7	11.1	3.7	2.7	10 54.3	10 56.0	10 24.4	3.7	2.7	9.7	7.0	15.7	11.4
38	10 39.5	10 41.3	10 10.4	3.8	2.7	9.8	6.9	15.8	11.2	3.8	2.8	10 54.5	10 56.3	10 24.7	3.8	2.8	9.8	7.1	15.8	11.5
39	10 39.8	10 41.5	10 10.6	3.9	2.8	9.9	7.0	15.9	11.3	3.9	2.8	10 54.8	10 56.5	10 24.9	3.9	2.8	9.9	7.2	15.9	11.5
40	10 40.0	10 41.8	10 10.8	4.0	2.8	10.0	7.1	16.0	11.3	4.0	2.9	10 55.0	10 56.8	10 25.2	4.0	2.9	10.0	7.3	16.0	11.6
41	10 40.3	10 42.0	10 11.1	4.1	2.9	10.1	7.2	16.1	11.4	4.1	3.0	10 55.3	10 57.0	10 25.4	4.1	3.0	10.1	7.3	16.1	11.7
42	10 40.5	10 42.3	10 11.3	4.2	3.0	10.2	7.2	16.2	11.5	4.2	3.0	10 55.5	10 57.3	10 25.6	4.2	3.0	10.2	7.4	16.2	11.7
43	10 40.8	10 42.5	10 11.6	4.3	3.0	10.3	7.3	16.3	11.5	4.3	3.1	10 55.8	10 57.5	10 25.9	4.3	3.1	10.3	7.5	16.3	11.8
44	10 41.0	10 42.8	10 11.8	4.4	3.1	10.4	7.4	16.4	11.6	4.4	3.2	10 56.0	10 57.8	10 26.1	4.4	3.2	10.4	7.5	16.4	11.9
45	10 41.3	10 43.0	10 12.0	4.5	3.2	10.5	7.4	16.5	11.7	4.5	3.3	10 56.3	10 58.0	10 26.4	4.5	3.3	10.5	7.6	16.5	12.0
46	10 41.5	10 43.3	10 12.3	4.6	3.3	10.6	7.5	16.6	11.8	4.6	3.3	10 56.5	10 58.3	10 26.6	4.6	3.3	10.6	7.7	16.6	12.0
47	10 41.8	10 43.5	10 12.5	4.7	3.3	10.7	7.6	16.7	11.8	4.7	3.4	10 56.8	10 58.5	10 26.8	4.7	3.4	10.7	7.8	16.7	12.1
48	10 42.0	10 43.8	10 12.8	4.8	3.4	10.8	7.7	16.8	11.9	4.8	3.5	10 57.0	10 58.8	10 27.1	4.8	3.5	10.8	7.8	16.8	12.2
49	10 42.3	10 44.0	10 13.0	4.9	3.5	10.9	7.7	16.9	12.0	4.9	3.6	10 57.3	10 59.0	10 27.3	4.9	3.6	10.9	7.9	16.9	12.3
50	10 42.5	10 44.3	10 13.2	5.0	3.5	11.0	7.8	17.0	12.0	5.0	3.6	10 57.5	10 59.3	10 27.5	5.0	3.6	11.0	8.0	17.0	12.3
51	10 42.8	10 44.5	10 13.5	5.1	3.6	11.1	7.9	17.1	12.1	5.1	3.7	10 57.8	10 59.6	10 27.8	5.1	3.7	11.1	8.0	17.1	12.4
52	10 43.0	10 44.8	10 13.7	5.2	3.7	11.2	7.9	17.2	12.2	5.2	3.8	10 58.0	10 59.8	10 28.0	5.2	3.8	11.2	8.1	17.2	12.5
53	10 43.3	10 45.0	10 13.9	5.3	3.8	11.3	8.0	17.3	12.3	5.3	3.8	10 58.3	11 00.1	10 28.3	5.3	3.8	11.3	8.2	17.3	12.5
54	10 43.5	10 45.3	10 14.2	5.4	3.8	11.4	8.1	17.4	12.3	5.4	3.9	10 58.5	11 00.3	10 28.5	5.4	3.9	11.4	8.3	17.4	12.6
55	10 43.8	10 45.5	10 14.4	5.5	3.9	11.5	8.1	17.5	12.4	5.5	4.0	10 58.8	11 00.6	10 28.7	5.5	4.0	11.5	8.3	17.5	12.7
56	10 44.0	10 45.8	10 14.7	5.6	4.0	11.6	8.2	17.6	12.5	5.6	4.1	10 59.0	11 00.8	10 29.0	5.6	4.1	11.6	8.4	17.6	12.8
57	10 44.3	10 46.0	10 14.9	5.7	4.0	11.7	8.3	17.7	12.5	5.7	4.1	10 59.3	11 01.1	10 29.2	5.7	4.1	11.7	8.5	17.7	12.8
58	10 44.5	10 46.3	10 15.1	5.8	4.1	11.8	8.4	17.8	12.6	5.8	4.2	10 59.5	11 01.3	10 29.5	5.8	4.2	11.8	8.6	17.8	12.9
59	10 44.8	10 46.5	10 15.4	5.9	4.2	11.9	8.4	17.9	12.7	5.9	4.3	10 59.8	11 01.6	10 29.7	5.9	4.3	11.9	8.6	17.9	13.0

## Azimuth of the Sun, Continued

Look at the left-hand column of the strip form below. Notice that you'll find values for Dec. Inc/Z Diff, Lat Inc/Z Diff, and LHA Inc/Z Diff. This is where we enter the leftover values from our whole degrees of DR Lat, Declination, and LHA. To do this, we must convert our leftover values into tenths of degrees by dividing each by 60 and rounding to the closest tenth of a degree. Finding Z Diff is a matter of inspecting Pub 229 (see figs. 9-3 and 9-4) in the following manner:

For Dec Inc/Z Diff note the values for the whole degree of dec that you entered the table with and the next high dec, then find the difference. Here are the values for our example problem: Dec  $19^{\circ}$  Z = 129.1 Dec  $20^{\circ}$  Z = 129.8. The difference between the values is 0.7. Since the value is increasing between  $19^{\circ}$  and  $20^{\circ}$ , we assign it a positive value (+).

Repeat the same procedure for finding Z Diff for Latitude and LHA. In other words, compare lat.  $33^{\circ}$  and lat  $34^{\circ}$ . Then compare LHA  $51^{\circ}$  and  $52^{\circ}$ .

OPNAV 3130/ Azimuth by 229	ACTION	Completed Strip Form
Tab Z	Enter Pub 229 with entering arguments of Lat $33^{\circ}$ , LHA $51^{\circ}$ , and Dec $19^{\circ}$ . Make sure that you enter on the portion of the page that indicates <b>LATITUDE CONTRARY TO DECLINATION</b> . Follow $19^{\circ}$ of Dec across the page to where it falls under the $33^{\circ}$ Latitude column and record the value for Tab Z.	129.1
Dec Inc/Z Diff	Dec. Inc (left) = $31.6' + 60$ which = .53 rounded to 0.5. Compares Z's for Z Diff.	0.5 / + 0.7
Dec Corr	Multiply Dec Inc by Z Diff.	+ 0.35
Lat Inc/Z Diff	Lat Inc (left) = $37.0' + 60$ which = .62 rounded to 0.6. Compares Z's for Z Diff.	0.6 / + 0.3
Lat Corr	Multiply Lat Inc by Z Diff.	+ 0.18
LHA Inc/Z Diff	LHA Inc (left) = $53.4' + 60$ which = .89 rounded to 0.9. Compares Z's for Z Diff.	0.9 / - 0.7
LHA Corr	Multiply LHA Inc by 2 Diff.	- 0.63
Dec Corr	Drop the Dec Corr Down.	+ 0.35
Lat Corr	Drop the Lat Corr Down.	+ 0.18
Total corr	Add the LHA, Dec, and Lat Corr.	- 0.10

We have now accounted for our leftover values and now can find the Exact Z.

# Azimuth of the Sun, Continued

LATITUDE CONTRARY NAME TO DECLINATION																		L.H.A. 51°, 309°										
Dec.	30°			31°			32°			33°			34°			35°			36°			37°			Dec.			
	Hc	d	Z	Hc	d	Z	Hc	d	Z	Hc	d	Z	Hc	d	Z	Hc	d	Z	Hc	d	Z	Hc	d	Z	Hc	d	Z	
0	33 01.5	36.0	112.0	32 38.7	36.9	112.6	32 15.3	37.8	113.2	31 51.4	38.7	113.8	31 26.9	39.5	114.4	31 01.9	40.3	114.9	30 36.4	41.2	115.5	30 10.3	41.9	116.0	0			
1	32 25.5	36.1	113.0	32 01.8	37.3	113.6	31 37.5	38.2	114.1	31 12.7	39.0	114.7	30 47.4	39.9	115.2	30 21.6	40.7	115.8	29 55.2	41.4	116.3	29 28.4	42.2	116.8	1			
2	31 49.1	36.2	113.9	31 24.5	37.7	114.5	30 59.3	38.5	115.0	30 33.7	39.4	115.6	30 07.5	40.2	116.1	29 40.9	41.0	116.6	29 13.8	41.8	117.1	28 46.2	42.5	117.6	2			
3	31 12.3	37.3	114.9	30 46.8	38.1	115.4	30 20.8	38.9	115.9	29 54.3	39.7	116.5	29 27.3	40.5	117.0	28 59.9	41.3	117.5	28 32.0	42.0	117.9	28 03.7	42.8	118.4	3			
4	30 35.0	37.6	115.8	30 08.7	38.4	116.3	29 41.9	39.3	116.8	29 14.6	40.1	117.3	28 46.8	40.8	117.8	28 18.6	41.6	118.3	27 50.0	42.4	118.8	27 20.9	43.1	119.2	4			
5	29 57.4	37.9	116.7	29 30.3	38.8	117.2	29 02.6	39.6	117.7	28 34.5	40.3	118.2	28 06.0	41.1	118.6	27 37.0	41.9	119.1	27 07.6	42.6	119.6	26 37.8	43.3	120.0	5			
6	29 19.5	38.2	117.6	28 51.5	39.1	118.1	28 23.0	39.9	118.5	27 54.2	40.7	119.0	27 24.9	41.5	119.5	26 55.1	42.1	119.9	26 25.0	42.8	120.3	25 54.5	43.5	120.8	6			
7	28 41.2	38.5	118.4	28 12.4	39.5	118.9	27 43.1	40.2	119.4	27 13.5	41.0	119.8	26 43.4	41.7	120.3	26 13.0	42.4	120.7	25 42.2	43.1	121.1	25 11.0	43.8	121.5	7			
8	28 02.5	39.0	119.3	27 32.9	39.7	119.8	27 02.9	40.5	120.2	26 32.5	41.2	120.7	26 01.7	41.9	121.1	25 30.6	42.7	121.5	24 59.1	43.4	121.9	24 27.2	44.0	122.3	8			
9	27 23.5	39.3	120.2	26 53.7	40.1	120.6	26 22.4	40.8	121.0	25 51.3	41.9	121.5	25 19.8	42.2	121.9	24 47.9	42.9	122.3	24 15.7	43.5	122.7	23 43.2	44.2	123.0	9			
10	26 44.2	39.5	121.0	26 13.1	40.3	121.4	25 41.6	41.0	121.9	25 09.8	41.8	122.3	24 37.6	42.5	122.7	24 05.0	43.1	123.0	23 32.2	43.8	123.4	22 59.0	44.4	123.8	10			
11	26 04.7	39.9	121.9	25 32.8	40.6	122.3	25 00.6	41.3	122.7	24 28.0	42.0	123.1	23 55.1	42.8	123.4	23 21.9	43.3	123.8	22 48.4	44.0	124.2	22 14.6	44.6	124.5	11			
12	25 24.8	40.2	122.7	24 52.2	40.9	122.3	24 19.3	41.4	123.5	23 46.0	42.2	123.8	23 12.5	42.9	124.2	22 38.6	43.6	124.5	22 04.4	44.2	124.9	21 30.0	44.8	125.2	12			
13	24 44.6	40.6	123.5	24 11.3	41.1	123.9	23 37.7	41.8	124.3	23 03.8	42.5	124.6	22 29.6	43.1	125.0	21 55.0	43.7	125.3	21 20.2	44.3	125.6	20 45.7	45.0	125.9	13			
14	24 04.2	40.7	124.3	23 30.2	41.3	124.7	22 55.9	42.0	125.0	22 21.3	42.6	125.4	21 46.5	43.4	125.7	21 11.3	43.9	126.0	20 35.9	44.6	126.3	20 00.2	45.1	126.6	14			
15	23 23.5	40.9	125.1	22 48.9	41.6	125.5	22 13.9	42.2	125.8	21 38.7	42.9	126.1	21 03.1	43.5	126.5	20 27.4	44.1	126.8	19 51.3	44.7	127.0	19 15.1	45.3	127.3	15			
16	22 42.6	41.1	125.9	22 07.3	41.8	126.3	21 31.7	42.5	126.6	20 55.8	43.1	126.9	20 19.6	43.6	127.2	19 43.3	44.3	127.5	19 06.6	44.8	127.8	18 29.8	45.5	128.0	16			
17	22 01.5	41.3	126.7	21 25.5	42.0	127.0	20 49.2	42.6	127.3	20 12.7	43.2	127.6	19 36.0	43.9	127.9	18 59.0	44.5	128.2	18 21.8	45.1	128.5	17 44.3	45.5	128.7	17			
18	21 20.1	41.6	127.5	20 43.5	42.2	127.8	20 06.6	42.8	128.1	19 29.5	43.5	128.4	18 52.1	44.0	128.6	18 14.5	44.6	128.9	17 36.7	45.1	129.2	16 58.8	45.8	129.4	18			
19	20 38.5	41.8	128.3	20 01.3	42.5	128.5	19 23.8	43.1	128.8	18 46.0	43.6	129.1	18 08.1	44.2	129.4	17 29.9	44.7	129.6	16 51.6	45.3	129.8	16 13.0	45.8	130.1	19			
20	19 56.7	41.9	129.0	19 18.8	42.5	129.3	18 40.7	43.1	129.6	18 02.4	43.7	129.8	17 23.9	44.3	130.1	16 45.2	44.9	130.3	16 06.3	45.5	130.5	15 27.2	46.0	130.7	20			
21	19 14.8	42.2	129.8	18 36.3	42.8	130.0	17 57.6	43.4	130.3	17 18.7	44.0	130.5	16 39.6	44.5	130.8	16 00.3	45.0	131.0	15 20.8	45.5	131.2	14 41.2	46.3	131.4	21			
22	18 32.6	42.5	130.5	17 53.5	42.9	130.8	17 14.2	43.5	131.0	16 34.7	44.0	131.3	15 55.1	44.6	131.5	15 15.3	45.2	131.7	14 35.3	45.7	131.9	13 55.2	46.2	132.1	22			
23	17 50.2	42.5	131.3	17 10.6	43.1	131.5	16 30.7	43.6	131.7	15 50.7	44.2	132.0	15 10.5	44.8	132.2	14 30.1	45.2	132.4	13 49.6	45.8	132.5	13 09.0	46.2	132.7	23			
24	17 07.7	42.8	132.0	16 27.5	43.1	132.5	15 43.2	44.1	132.7	15 06.1	44.4	132.9	14 24.2	44.8	133.1	13 40.2	45.2	133.4	13 06.2	45.8	133.5	12 26.7	46.4	133.7	24			
25	16 25.1	42.9	132.8	15 44.9	43.2	133.0	15 06.1	44.1	133.2	14 29.0	44.4	133.4	13 51.1	44.9	133.7	13 13.1	45.2	134.0	12 35.1	45.8	134.1	11 57.0	46.6	134.3	25			
26	15 42.3	43.0	133.5	15 02.7	43.3	133.5	14 30.0	44.1	133.7	13 52.9	44.6	134.0	13 15.8	45.0	134.3	12 40.7	45.4	134.6	12 04.6	46.0	134.8	11 28.4	46.8	135.0	26			
27	15 00.0	43.1	134.2	14 20.5	43.4	134.0	13 54.8	44.3	134.2	13 27.7	44.8	134.5	12 52.6	45.2	134.8	12 21.5	45.6	135.1	11 45.4	46.2	135.4	11 00.1	47.0	135.6	27			
28	14 17.8	43.2	134.9	13 38.3	43.5	134.5	13 09.6	44.4	134.7	12 42.5	44.9	135.0	12 15.4	45.4	135.3	11 44.3	45.9	135.6	11 17.2	46.4	135.9	10 38.9	47.4	136.0	28			
29	13 35.6	43.3	135.6	12 56.1	43.6	135.0	12 32.4	44.5	135.2	12 05.3	45.0	135.5	11 38.2	45.6	135.8	11 11.1	46.1	136.1	10 44.0	46.6	136.4	10 06.7	47.6	136.3	29			
30	12 53.4	43.4	136.3	12 13.9	43.7	135.7	11 50.2	44.6	135.9	11 23.1	45.1	136.2	10 54.0	45.8	136.5	10 26.9	46.3	136.8	9 58.8	46.8	137.1	9 21.5	47.8	137.1	30			
31	12 11.2	43.5	137.0	11 31.7	43.8	136.4	11 08.0	44.7	136.6	10 40.9	45.2	136.8	10 13.8	45.9	137.1	9 46.7	46.4	137.4	9 19.6	46.9	137.7	8 42.4	48.0	137.4	31			
32	11 29.0	43.6	137.7	10 49.5	43.9	137.1	10 25.8	44.8	137.3	9 58.7	45.3	137.5	9 31.6	46.0	137.8	9 04.5	46.5	138.1	8 37.4	47.0	138.4	8 00.2	48.4	138.1	32			
33	10 46.8	43.7	138.4	10 07.3	44.0	137.8	9 43.6	44.9	137.9	9 16.5	45.4	138.2	8 44.4	46.1	138.5	8 17.3	46.6	138.8	7 50.2	47.1	139.1	7 13.0	49.0	138.8	33			
34	10 04.6	43.8	139.1	9 25.1	44.1	138.5	8 59.4	45.0	139.0	8 32.3	45.5	139.4	8 03.1	46.2	139.7	7 36.0	46.7	140.0	7 08.9	47.2	140.3	6 31.7	49.4	139.5	34			
35	9 22.4	43.9	139.8	8 42.9	44.2	139.2	8 17.2	45.1	139.7	7 50.1	45.6	140.1	7 20.9	46.3	140.4	6 54.8	46.8	140.7	6 27.7	47.3	141.0	5 51.5	49.6	140.0	35			
36	8 40.2	44.0	140.5	8 00.7	44.3	140.0	7 41.0	45.2	140.5	7 13.9	45.7	140.9	6 44.7	46.4	141.2	6 18.4	46.9	141.5	5 51.2	47.4	141.8	5 24.9	49.8	140.3	36			
37	8 00.0	44.1	141.2	7 18.5	44.4	140.7	6 59.8	45.3	141.0	6 32.7	45.8	141.4	6 06.4	46.6	141.7	5 41.1	47.1	142.0	5 14.0	47.5	142.3	4 42.7	50.0	140.6	37			
38	7 20.0	44.2	141.9	6 36.3	44.5	141.4	6 17.6	45.4	141.7	5 50.5	45.9	142.1	5 24.2	46.8	142.4	4 56.9	47.4	142.7	4 29.8	47.8	143.0	4 02.5	50.2	140.9	38			
39	6 40.0	44.3	142.6	5 54.1	44.6	142.1	5 35.4	45.5	142.4	5 08.3	46.0	142.8	4 34.9	47.1	143.1	4 11.6	47.6	143.4	3 44.5	48.0	143.7	3 17.2	50.4	141.2	39			
40	6 00.0	44.4	143.3	5 11.9	44.7	142.8	4 53.7	45.6	143.1	4 26.6	46.1	143.5	3 56.1	47.2	143.8	3 32.8	47.7	144.1	3 01.4	48.1	144.4	2 29.0	50.6	141.5	40			
41	5 20.0	44.5	144.0	4 29.7	44.8	143.5	4 11.5	45.7	143.8	3 44.4	46.2	144.2	3 16.8	47.3	144.5	2 53.0	47.8	144.8	2 21.6	48.2	145.1	1 49.2	50.8	141.8	41			
42	4 40.0	44.6	144.7	3 47.5	44.9	144.2	3 29.3	45.8	144.5	3 17.2	46.3	144.9	2 50.6	47.4	145.2	2 27.0	48.1	145.5	1 55.8	48.5	145.8	1 23.4	51.0	142.1	42			
43	4 00.0	44.7	145.4	3 05.3	45.0	144.9	2 47.1	45.9	145.2	2 29.0	46.4	145.6	2 01.4	47.5	145.9	1 40.0	48.2	146.2	1 10.2	48.8	146.5	0 37.8	51.2	142.4	43			
44	3 20.0	44.8	146.1	2 23.1	45.1	145.6	2 04.9	46.0	145.9	1 42.8	46.5	146.3	1 17.2	47.6	146.6	0 51.6	4											



# Azimuth of the Sun, Continued

## LATITUDE CONTRARY NAME TO DECLINATION

L.H.A. 52°, 308°

Dec.	30°			31°			32°			33°			34°			35°			36°			37°			Dec.											
	Mc	d	Z	Mc	d	Z	Mc	d	Z	Mc	d	Z	Mc	d	Z	Mc	d	Z	Mc	d	Z	Mc	d	Z												
0	32	132	35	111	3	31	51	3	111	9	31	28	4	112	5	31	05	2	113	1	30	17	2	114	1	29	52	4	114	7	29	27	1	115	2	0
1	31	37	6	112	3	21	14	5	112	8	30	51	3	113	4	30	26	9	113	9	30	02	3	114	5	29	11	6	115	2	28	45	5	116	0	1
2	31	01	5	113	2	30	37	5	113	8	30	13	4	114	3	29	48	2	114	8	29	22	7	115	3	28	30	4	116	0	28	03	4	116	8	2
3	30	25	0	114	1	30	00	2	114	7	29	34	9	115	2	29	09	1	115	7	28	42	9	116	2	28	16	1	116	7	27	49	4	117	6	3
4	29	48	1	115	1	29	22	5	115	6	28	58	3	116	1	28	29	7	116	6	28	02	7	117	0	27	35	2	117	5	27	07	2	118	4	4
5	29	10	9	116	0	28	44	4	116	5	28	17	4	117	0	27	50	0	117	4	27	22	0	118	3	26	53	9	118	3	25	56	2	119	2	5
6	28	33	3	117	0	28	35	9	117	3	27	38	2	118	7	27	10	0	118	7	26	41	4	119	1	25	43	0	119	6	25	13	2	120	0	6
7	27	55	3	118	0	27	27	1	118	2	26	58	6	118	6	26	29	7	119	1	26	00	3	119	5	25	36	6	120	3	24	30	4	120	7	7
8	27	17	0	119	0	26	48	1	119	0	26	18	8	119	5	25	49	1	119	9	25	19	0	120	3	24	48	5	120	7	24	17	1	121	5	8
9	26	38	3	120	0	26	08	3	120	9	25	37	5	120	3	25	08	2	120	7	24	37	4	121	1	24	06	2	121	5	23	34	7	121	9	9
10	25	59	6	121	0	25	29	1	121	7	24	58	3	121	1	24	27	1	121	5	24	17	0	122	1	23	23	7	122	3	22	51	4	122	3	10
11	25	20	4	122	0	24	49	1	122	5	24	17	6	122	3	23	45	7	122	3	23	15	4	123	0	22	40	9	123	0	22	08	0	123	4	11
12	24	40	9	123	0	24	08	9	123	4	23	36	7	123	2	23	04	1	123	1	22	31	4	123	4	21	37	9	123	8	21	24	4	124	4	12
13	24	01	1	124	0	23	28	5	124	3	22	55	5	124	1	22	22	2	124	0	21	48	6	124	2	21	14	7	124	5	20	40	6	124	8	13
14	23	21	1	125	0	22	47	8	125	2	22	14	1	125	0	21	40	1	125	0	21	05	9	125	0	20	31	4	125	3	19	56	4	125	6	14
15	22	40	9	126	0	22	06	8	126	0	21	32	5	126	0	20	57	8	126	0	20	22	9	126	0	19	17	4	126	3	18	36	8	126	6	15
16	22	00	4	127	0	21	25	6	127	0	20	50	6	127	0	20	15	3	127	0	19	39	8	127	0	19	04	1	127	2	17	28	1	127	5	16
17	21	19	6	128	0	20	44	2	128	0	20	08	4	128	0	19	32	7	128	0	19	16	5	128	0	18	20	2	128	4	17	43	6	128	7	17
18	20	38	7	129	0	20	02	6	129	0	19	26	3	129	0	18	49	8	129	0	18	13	4	129	0	17	36	1	129	8	16	58	9	129	1	18
19	19	57	5	130	0	19	20	8	130	0	18	43	1	130	0	18	06	8	130	0	17	29	4	130	0	16	51	9	130	8	15	31	4	130	1	19
20	19	16	2	131	0	18	38	9	131	0	18	01	3	131	0	17	23	6	131	0	16	45	6	131	0	16	07	5	131	9	14	50	7	131	0	20
21	18	34	6	132	0	17	56	7	132	0	17	18	5	132	0	16	40	2	132	0	16	01	7	132	0	15	23	0	132	3	14	44	1	132	0	21
22	17	52	9	133	0	17	14	4	133	0	16	35	6	133	0	15	56	7	133	0	15	17	6	133	0	14	34	4	133	8	13	58	9	133	0	22
23	17	11	0	134	0	16	31	9	134	0	15	52	3	134	0	15	13	0	134	0	14	32	4	134	0	13	13	3	134	4	13	13	2	134	0	23
24	16	28	2	135	0	15	49	2	135	0	15	10	0	135	0	14	25	0	135	0	14	14	3	135	0	13	13	2	135	1	12	42	4	135	0	24

25	7	54	0	139	9	6	22	1	140	0	5	36	0	140	2	4	49	0	140	2	4	03	8	140	3	3	17	7	140	3	2	31	5	140	3	25	
26	7	10	5	140	6	6	24	1	140	7	5	30	4	140	7	4	47	1	140	7	3	18	1	140	7	2	31	5	140	7	1	44	9	140	7	26	
27	6	26	9	141	3	5	40	1	141	4	4	24	0	141	4	3	19	3	141	4	2	32	3	141	4	1	45	3	141	4	0	58	2	141	4	27	
28	5	43	3	142	0	4	56	0	142	1	4	07	4	142	1	2	33	9	142	1	1	46	5	142	1	0	59	0	142	2	0	11	6	142	2	28	
29	4	59	6	143	0	4	11	9	143	8	3	24	1	143	8	2	36	3	143	8	1	50	7	143	8	0	12	8	143	9	0	35	0	143	9	29	
30	4	15	9	144	0	3	27	7	144	5	2	39	5	144	5	1	51	3	144	5	0	14	8	144	5	0	14	8	144	5	0	19	6	144	5	30	
31	3	32	1	145	0	2	43	2	145	1	1	54	9	145	1	0	1	0	145	1	0	17	6	145	1	0	1	19	6	145	1	0	2	0	145	1	31
32	2	48	3	146	0	1	59	3	146	0	1	03	3	146	0	0	2	1	146	0	0	1	16	8	146	0	0	2	05	8	0	2	5	146	0	32	
33	2	05	4	147	0	1	15	4	147	0	0	25	7	147	0	0	7	8	147	0	0	0	2	147	0	0	0	2	07	8	0	3	4	147	0	33	
34	1	20	7	148	0	0	30	8	148	0	0	19	0	148	0	0	1	0	148	0	0	0	1	148	0	0	0	0	1	148	0	0	0	0	148	0	34
35	0	36	8	149	0	0	14	4	149	0	0	11	3	149	0	0	0	1	149	0	0	0	0	149	0	0	0	0	0	149	0	0	0	0	149	0	35
36	0	07	0	150	0	0	0	3	150	0	0	0	3	150	0	0	0	0	150	0	0	0	0	150	0	0	0	0	0	150	0	0	0	0	150	0	36
37	0	00	0	151	0	0	0	0	151	0	0	0	0	151	0	0	0	0	151	0	0	0	0	151	0	0	0	0	0	151	0	0	0	0	151	0	37
38	0	00	0	152	0	0	0	0	152	0	0	0	0	152	0	0	0	0	152	0	0	0	0	152	0	0	0	0	0	152	0	0	0	0	152	0	38
39	0	00	0	153	0	0	0	0	153	0	0	0	0	153	0	0	0	0	153	0	0	0	0	153	0	0	0	0	0	153	0	0	0	0	153	0	39
40	0	00	0	154	0	0	0	0	154	0	0	0	0	154	0	0	0	0	154	0	0	0	0	154	0	0	0	0	0	154	0	0	0	0	154	0	40
41	0	00	0	155	0	0	0	0	155	0	0	0	0	155	0	0	0	0	155	0	0	0	0	155	0	0	0	0	0	155	0	0	0	0	155	0	41
42	0	00	0	156	0	0	0	0	156	0	0	0	0	156	0	0	0	0	156	0	0	0	0	156	0	0	0	0	0	156	0	0	0	0	156	0	42
43	0	00	0	157	0	0	0	0	157	0	0	0	0	157	0	0	0	0	157	0	0	0	0	157	0	0	0	0	0	157	0	0	0	0	157	0	43
44	0	00	0	158	0	0	0	0	158	0	0	0	0	158	0	0	0	0	158	0	0	0	0	158	0	0	0	0	0	158	0	0	0	0	158	0	44
45	0	00	0	159	0	0	0	0	159	0	0	0	0	159	0	0	0	0	159	0	0	0	0	159	0	0	0	0	0	159	0	0	0	0	159	0	45
46	0	00	0	160	0	0	0	0	160	0	0	0	0	160	0	0	0	0	160	0	0	0	0	160	0	0	0	0	0	160	0						

## Azimuth of the Sun, Continued

Tab Z	Drop the value from Tab Z.	129.1
Exact Z (-360)	Apply the Total Corr to Tab Z (- 0.10).	129.0
Exact Zn	<p>On each page of Pub 229 are small notes that state:</p> <p>In N. Lat. if LHA is <b>Greater than 180 then Zn= Z</b>  if LHA is <b>Less than 180 then Zn= 360-Z</b></p> <p>In S. Lat. if LHA is <b>Greater than 180 then Zn= 180-Z</b>  if LHA is <b>Less than 180 then Zn= 180+Z</b></p> <p>Our Lat is N. and LHA is <b>less than 180</b>,  therefore Zn=360 - 129 or 231°.</p>	231.0
Gyro Bearing	Enter the gyro bearing from the observation.	231.6
Gyro Error	<p>Find the difference between Exact Zn and the gyro bearing and name the error. If the gyro bearing is less than the Exact Zn, the error is easterly, if more than Exact Zn, it's westerly. Use this memory aid:</p> <p>Gyro least - error east, Gyro best - error west.</p>	0.6 West

We have now used the Sun to find the error on our gyrocompass. As stated before, a greater degree of accuracy can be obtained by making several observations and then working the solutions and averaging the results. This may seem a bit tedious, however, you may work all observations at once. This is easily accomplished by entering data in the strip form in stages.

Try this method. First enter GMT DR Lat, DR Long, GHA, Dec, and d#. Next find Incements (m/s), LHA, and True Dec. Now find your leftover values for Dee Inc, Lat Inc, and LHA Inc and enter Pub 229.

Once you have completed the solutions for all observations, you can average the results. Here's an example:

Error 1 = .6 W Error 2 = .5 W Error 3 = .7 W for a total of  $1.8 \div 3 = .6$  W

# Azimuth by Polaris

## Azimuth by Polaris

Polaris (the North Star) is always within about 2° of true north. The true azimuth of Polaris is tabulated in the *Nautical Almanac* in the Polaris Tables for northern latitudes up to 65°.

**Gathering Information:** The entering arguments for the Polaris Tables are the LHA of Aries (GHA of Aries plus east longitude or minus west longitude) and latitude (at intervals of 5°, 10° or 20°). An extract from the *Nautical Almanac* Polaris azimuth table, which appears at the foot of the Polaris Tables, is shown in figure 9-5. As you can see, the interpolation can be done by visual inspection of the appropriate LHA and latitude.

The normal use of Polaris for obtaining compass error is when your ship is in the lower northern latitudes. This allows you to take a bearing on Polaris using the telescopic alidade. Since the computation and interpolation of azimuth by Polaris are relatively simple, we will not go into step-by-step procedures in this text.

POLARIS (POLE STAR) TABLES, 1983												275
FOR DETERMINING LATITUDE FROM SEXTANT ALTITUDE AND FOR AZIMUTH												
L.H.A. ARIES	120°- 129°	130°- 139°	140°- 149°	150°- 159°	160°- 169°	170°- 179°	180°- 189°	190°- 199°	200°- 209°	210°- 219°	220°- 229°	230°- 239°
Lat.	AZIMUTH											
0	359·2	359·2	359·2	359·3	359·4	359·5	359·6	359·7	359·9	0·0	0·2	0·3
20	359·1	359·2	359·2	359·3	359·4	359·5	359·6	359·7	359·9	0·0	0·2	0·3
40	358·9	359·0	359·0	359·1	359·2	359·3	359·5	359·7	359·8	0·0	0·2	0·4
50	358·7	358·8	358·8	358·9	359·1	359·2	359·4	359·6	359·8	0·0	0·2	0·5
55	358·6	358·6	358·7	358·8	359·0	359·1	359·3	359·6	359·8	0·0	0·3	0·5
60	358·4	358·4	358·5	358·6	358·8	359·0	359·2	359·5	359·8	0·0	0·3	0·6
65	358·1	358·1	358·2	358·4	358·6	358·8	359·1	359·4	359·7	0·0	0·4	0·7

26NYM036

Figure 9-5. Extract from the *Nautical Almanac* Polaris Tables.

# Amplitude of the Sun

---

## Amplitude

An amplitude of the Sun or other celestial body can be used to determine gyro error. An amplitude (A) is the arc of the horizon between the prime vertical circle (the vertical circle through the east and west points of the horizon) and the observed body. The prime vertical circle may be true or magnetic depending upon which east or west points are involved. If the body is observed when its center is on the celestial horizon, the amplitude can be taken directly from table 27 of *Bowditch*, Volume II.

---

## Horizons

The celestial horizon differs from the one you see (the visible horizon) because it runs through the center of Earth. There are a lot of computations that must be done to determine the celestial horizon of a body, but for now we will just say that it is the horizon that a navigator uses for all celestial computations.

When the center of the Sun is on the celestial horizon, its lower limb (lower edge) is about two-thirds of the diameter of the Sun above the visible horizon. When the center of the Moon is on the celestial horizon, its upper limb (upper edge) is on the visible horizon.

Figure 9-6 shows the relationship of the visible horizon to the celestial horizon. When planets and stars are on the celestial horizon, they are a little more than one Sun diameter above the visible horizon.

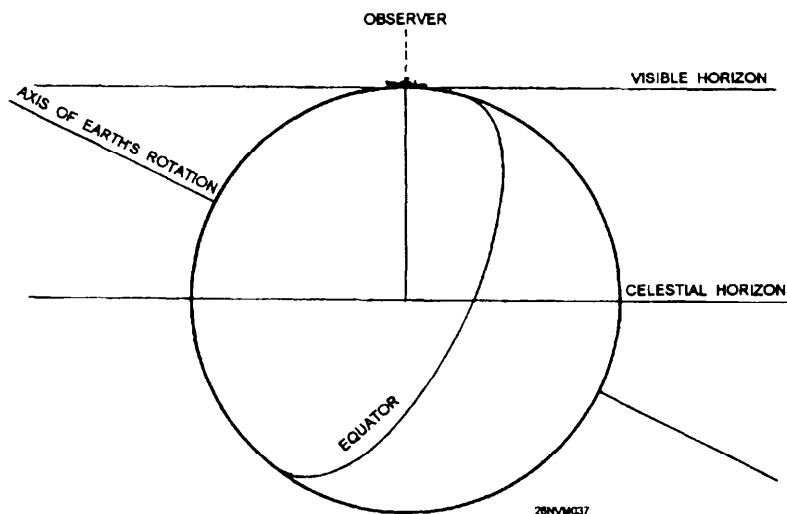

Figure 9-6. The visible and celestial horizons.

## Amplitude of the Sun, Continued

---

### Labeling the Amplitude

The amplitude of a body is given the prefix E (east) if the body is rising and the prefix W (west) if the body is setting. Additionally, the amplitude of a body is given the suffix N (north) if the body has northerly declination and the suffix S (south) if it has southerly declination.

---

### Finding Amplitude of the Sun Using the Celestial Horizon

As discussed above, the amplitude of a body can be taken directly from table 27 of *Bowditch*, Volume II, if the body is observed when its center is on the celestial horizon. Since the Sun is most commonly used for amplitudes, it will be the topic of our discussion.

**Gathering Information:** To observe the Sun when it is on the celestial horizon, its lower limb must be about two-thirds of the diameter above the visible horizon. You must know the Greenwich mean time (GMT) of your observation to determine the Sun's declination from the right-hand daily pages of the *Nautical Almanac*, your DR Lat. at the time of observation, and the true bearing of the Sun as observed using a telescopic alidade.

---

### Example Problem

The DR latitude of your ship is  $51^{\circ}04.6'N$ . The declination of the setting Sun was  $19^{\circ}00.4'N$ . Your true bearing (as observed by a telescopic alidade) to the Sun was  $300^{\circ}$ .

From this known information, we can use table 27 of *Bowditch* to determine the amplitude.

Figure 9-7 shows an excerpt from table 27. By inspection of figure 9-7, you can see that you must enter the left-hand column with your ship's DR latitude. You can also see that the Sun's declination is listed across the top of the table. Since latitude  $51^{\circ}$  and declination  $19^{\circ}$  are closest to our entering values, we determine that the amplitude of the Sun when it is on the celestial horizon is  $31.2^{\circ}$ . Now that we have the amplitude, what do we do with it? First of all, there are some basic rules that must be applied that relate to our previous discussion of the assigned prefix and suffix of an amplitude. Our amplitude was taken when the Sun was setting, and its declination name is north. Using the rules for labeling the amplitude, we label the amplitude as follows:  $W\ 31.2^{\circ}\ N$ . We use W because the Sun is setting and N because the Sun's declination is N.

# Amplitude of the Sun, Continued

TABLE 27 Amplitudes														
Latitude	Declination													Latitude
	18°0	18°5	19°0	19°5	20°0	20°5	21°0	21°5	22°0	22°5	23°0	23°5	24°0	
0	18.0	18.5	19.0	19.5	20.0	20.5	21.0	21.5	22.0	22.5	23.0	23.5	24.0	0
10	18.3	18.8	19.3	19.8	20.3	20.8	21.3	21.8	22.4	22.9	23.4	23.9	24.4	10
15	18.7	19.2	19.7	20.2	20.7	21.3	21.8	22.3	22.8	23.3	23.9	24.4	24.9	15
20	19.2	19.7	20.3	20.8	21.3	21.9	22.4	23.0	23.5	24.0	24.6	25.1	25.6	20
25	19.9	20.5	21.1	21.6	22.2	22.7	23.3	23.9	24.4	25.0	25.5	26.1	26.7	25
30	20.9	21.5	22.1	22.7	23.3	23.9	24.4	25.0	25.6	26.2	26.8	27.4	28.0	30
32	21.4	22.0	22.6	23.2	23.8	24.4	25.0	25.6	26.2	26.8	27.4	28.0	28.7	32
34	21.9	22.5	23.1	23.7	24.4	25.0	25.6	26.2	26.9	27.5	28.1	28.7	29.4	34
36	22.5	23.1	23.7	24.4	25.0	25.7	26.3	26.9	27.6	28.2	28.9	29.5	30.2	36
38	23.1	23.7	24.4	25.1	25.7	26.4	27.1	27.7	28.4	29.1	29.7	30.4	31.1	38
40	23.8	24.5	25.2	25.8	26.5	27.2	27.9	28.6	29.3	30.0	30.7	31.4	32.1	40
41	24.2	24.9	25.6	26.3	26.9	27.6	28.3	29.1	29.8	30.5	31.2	31.9	32.6	41
42	24.6	25.3	26.0	26.7	27.4	28.1	28.8	29.5	30.3	31.0	31.7	32.5	33.2	42
43	25.0	25.7	26.4	27.2	27.9	28.6	29.3	30.1	30.8	31.6	32.3	33.0	33.8	43
44	25.4	26.2	26.9	27.6	28.4	29.1	29.9	30.6	31.4	32.1	32.9	33.7	34.4	44
45	25.9	26.7	27.4	28.2	28.9	29.7	30.5	31.2	32.0	32.8	33.5	34.3	35.1	45
46	26.4	27.2	27.9	28.7	29.5	30.3	31.1	31.8	32.6	33.4	34.2	35.0	35.8	46
47	26.9	27.7	28.5	29.3	30.1	30.9	31.7	32.5	33.3	34.1	35.0	35.8	36.6	47
48	27.5	28.3	29.1	29.9	30.7	31.6	32.4	33.2	34.0	34.9	35.7	36.6	37.4	48
49	28.1	28.9	29.8	30.6	31.4	32.3	33.1	34.0	34.8	35.7	36.6	37.4	38.3	49
50	28.7	29.6	30.4	31.3	32.1	33.0	33.9	34.8	35.6	36.5	37.4	38.3	39.3	50
51	29.4	30.3	31.2	32.0	32.9	33.8	34.7	35.6	36.5	37.5	38.4	39.3	40.3	51
52	30.1	31.0	31.9	32.8	33.7	34.7	35.6	36.5	37.5	38.4	39.4	40.4	41.3	52
53	30.9	31.8	32.8	33.7	34.6	35.6	36.5	37.5	38.5	39.5	40.5	41.5	42.5	53
54	31.7	32.7	33.6	34.6	35.6	36.6	37.6	38.6	39.6	40.6	41.7	42.7	43.8	54
70.0	64.6	68.1	72.2	77.4	90.0									70.0
70.5	67.8	71.9	77.2	90.0										70.5
71.0	71.7	77.1	90.0											71.0
71.5	76.9	90.0												71.5
72.0	90.0													72.0

26NVM038

Figure 9-7. Excerpt from table 27.

## Amplitude of the Sun, Continued

---

### Finding Amplitude of the Sun Using the Celestial Horizon, continued

With the amplitude properly labeled, we can now follow another set of rules to determine the azimuth.

#### Rules:

1. Rising Sun with north declination, subtract the amplitude from  $090^\circ$
2. Rising Sun with south declination, add the amplitude to  $090^\circ$
3. Setting Sun with north declination, add the amplitude to  $270^\circ$
4. Setting Sun with south declination, subtract the amplitude from  $270^\circ$

By following the rules above, our amplitude can now be converted to an azimuth as follows:

$$W31.2^\circ N + 270^\circ = 301.2^\circ$$

Our true bearing to the Sun was  $300^\circ$ . Gyro error can be determined as follows:

$$\begin{array}{r} 301.2^\circ \text{ (azimuth)} \\ \underline{300.0^\circ \text{ (gyro bearing)}} \\ 1.2^\circ \text{ E (gyro error)} \end{array}$$

We find the name of the error by using our memory aid

***Gyro least - error EAST, Gyro best - error WEST.***

---

### Finding Amplitude Using the Visible Horizon

If the body is observed when its center is on the visible horizon, a correction from table 28 of *Bowditch*, Volume II, is applied to the value taken from *Bowditch's* table 27. Refer to table 28 for step-by-step instructions.

# The Celestial LOP

---

## General Information

You have seen how lines of position, obtained through bearings on terrestrial objects, are used to fix a ship's position in piloting. You know that a line of position (LOP) is a locus of possible positions of the ship. In other words, the ship's position must be somewhere along that line. A fix, by definition, is a relatively accurate determination of latitude and longitude. In practice, this position is the intersection of two or more lines of position; but often it is not the ship's exact position because you can always assume some errors in observation, plotting, and the like.

The celestial navigator must establish lines of position by applying the results of observations of heavenly bodies. A line of position obtained at one time may be used at a later time. All you need to do is move the line parallel to itself, a distance equal to the run of the ship in the interim, and in the same direction as the run. Such a line of position cannot be as accurate as a new line because the amount and direction of its movement can be determined only by the usual DR methods. If two new lines cannot be obtained, however, an old line, advanced and intersected with a new one, may be the only possible way of establishing a fix. Naturally, the distance an old line may be advanced without a substantial loss of accuracy depends on how closely the run can be reckoned.

In celestial navigation, as in piloting, you essentially are trying to establish the intersection of two or more lines of position. A single observation and the resulting LOP is insufficient to obtain a fix.

The most accurate method of obtaining a celestial fix is to take sights on many bodies in a short time. For example, it is quite common to take sights on six or more stars in a period of 15 minutes or less. Taking sights on many bodies allows the observer to identify and throw out LOPS with obvious errors.

---

## Determining the LOP

You might be entitled to complain that much has been said concerning what an LOP tells you, but very little has been told about how you determine it in the first place. We are coming to that part now.

The first item is to take on a heavenly body or bodies and then reduce the sights. Reducing the sights taken gives you the information you need to plot the LOP. The LOPS then gives you the resulting fix.



# The Celestial LOP

## Determining the LOP, continued

Figure 9-8 illustrates the method used in establishing a single LOP by observing a star. An assumed position (AP) is selected according to certain requirements of convenience in calculating (described later). Observation of a star provides sextant altitude ( $h_s$ ). Sextant altitude is then corrected to obtain observed altitude ( $H_o$ ). The star's altitude from the assumed position, called the computed altitude ( $H_c$ ), and its azimuth angle are determined from tables by a procedure you will soon learn. The azimuth angle is then converted to azimuth. After selecting an AP, draw the azimuth through the AP. Along the azimuth, measure off the altitude intercept (difference between the observed altitude and the computed altitude). At the end of this measurement, draw a perpendicular line, which is the LOP. You must know whether altitude intercept ( $a$ ) should be measured from AP toward the body or from AP measured away from the body. It is helpful to remember the initials  $H_o$  MO  $T_o$ , if  $H_o$  is more toward. This means that if  $H_o$  is greater than  $H_c$  measure altitude intercept ( $a$ ) from AP toward the body. If  $H_c$  is greater than  $H_o$  measure altitude intercept ( $b$ ) from AP away from the body.

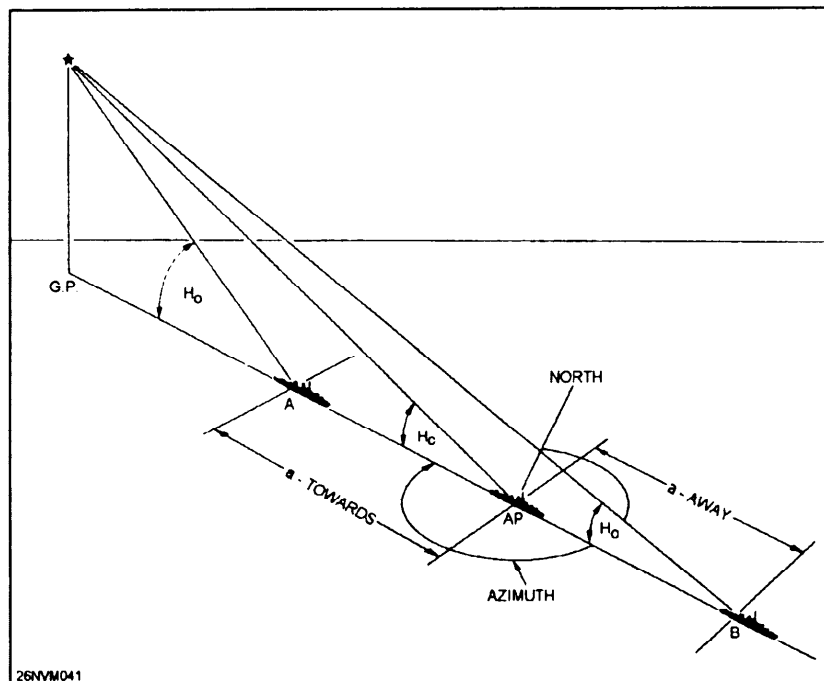

Figure 9-8. Determining a LOP.

# Using the Sextant

## General

The sextant is the instrument of chief importance in celestial navigation. It is used to measure the altitude of a heavenly body above the visible horizon. Sextant altitude is corrected for various factors to determine the body's true (or corrected) altitude above the celestial horizon.

## Techniques

Here are some techniques commonly used to take sights with the marine sextant. It will always be necessary to find any index error prior to taking sights; refer to chapter 8 to find index error.

Use the following step action table for the general steps to take sights on the Sun. The steps for stars and planets are basically the same, except you would omit steps 2 and 4.

Step	Action							
1.	Hold the sextant level with the horizon and determine index error.							
2.	<b>CAUTION: Set shade filters in place now, or eye burns may result.</b>							
3.	Aim the sextant to a point on the horizon directly below the Sun.							
4.	<table border="1"> <thead> <tr> <th>IF...</th> <th>THEN...</th> </tr> </thead> <tbody> <tr> <td>the Sun is rising</td> <td>Move the index arm slowly outward from the 0° position until the Sun's lower limb is just <i>below</i> the horizon.</td> </tr> <tr> <td>the Sun is setting</td> <td>Move the index arm slowly outward from the 0° position until the Sun's lower limb is just <i>above</i> the horizon.</td> </tr> </tbody> </table>		IF...	THEN...	the Sun is rising	Move the index arm slowly outward from the 0° position until the Sun's lower limb is just <i>below</i> the horizon.	the Sun is setting	Move the index arm slowly outward from the 0° position until the Sun's lower limb is just <i>above</i> the horizon.
IF...	THEN...							
the Sun is rising	Move the index arm slowly outward from the 0° position until the Sun's lower limb is just <i>below</i> the horizon.							
the Sun is setting	Move the index arm slowly outward from the 0° position until the Sun's lower limb is just <i>above</i> the horizon.							
5.	Swing the arc. This means to gently move your hand grasping the sextant handle in a small upward arcing motion. Up to the left, then back to the right. You will see the reflected image of the Sun arc back and forth.							
6.	Give the recorder a standby to mark (marking the exact time of the sight). Continue swinging the arc while turning the micrometer drum slightly until the lower limb of the Sun touches the horizon. At that exact moment, <i>mark</i> the time of the sight and record the sextant altitude.							

# Altitude Corrections

---

## Altitude Corrections

Of the following five altitude corrections, the first three apply to observations of all celestial bodies. The last two corrections are applicable only when the observed body belongs to the solar system. Figure 9-9 illustrates the correction problem. To obtain the true altitude, you must correct the sextant altitude of any celestial body for:

1. **Index error**, which is the constant instrument error caused by a lack of perfect parallelism between the index mirror and horizon glass when the sextant is set at  $0^\circ$ .
2. **Refraction**, which is the deviation of rays of light from a straight line caused by Earth's atmosphere.
3. **Dip of the horizon**, which is the difference in direction between the visible and celestial horizons caused by the observer's height above the surface.

If the observed body belongs to the solar system, corrections must also be made for:

4. **Parallax**, which is caused by the proximity of bodies of the solar system to Earth, resulting in a difference in altitudes measured from the surface of Earth and from the center of Earth. Such an occurrence is not true of other heavenly bodies whose distance from Earth is considered infinite.
5. **Semidiameter**, which results from the nearness of bodies of the solar system, which makes it necessary to consider the observed bodies as appreciable size instead of as mere points of light; for example, stars. The sextant altitude of such a body is obtained by bringing its disk tangent to the horizon. Semidiameter correction must be applied to find the altitude of the center.

# Altitude Corrections, Continued

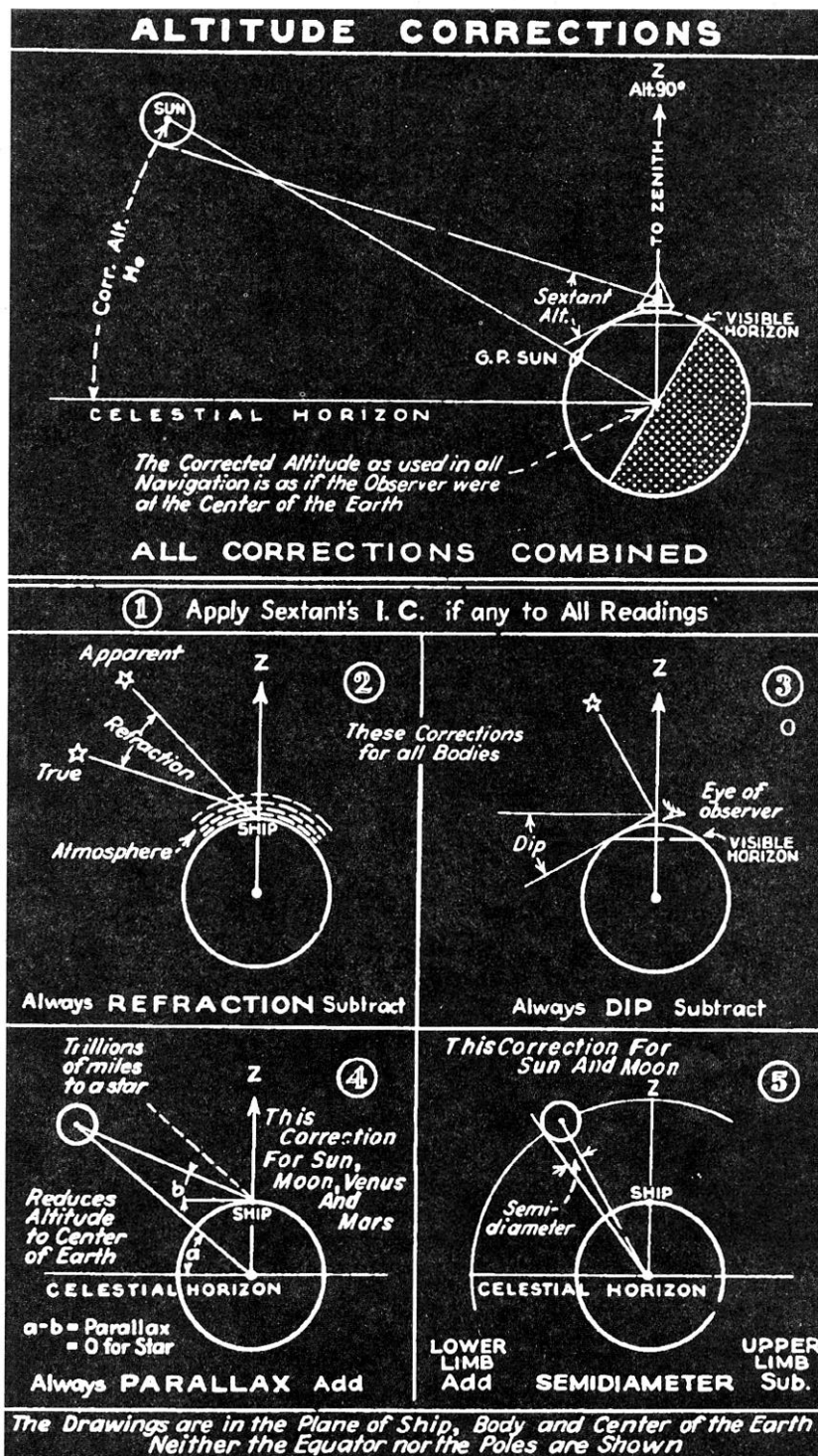

Figure 9-9. Sextant altitude corrections.

## Altitude Corrections, Continued

### Corrections Defined

We will explore each altitude correction in detail. Applying altitude corrections is the starting point for reducing sights for any observation.

Name	Description
Index Error	The amount of instrument error in the sextant (covered in chapter 8).
Refraction	<p>Earth is wrapped in a blanket of atmosphere more than 50 miles deep. Density of the atmosphere, like that of the ocean, increases with depth and is greatest at the bottom, next to Earth's surface. Light rays do not follow a straight line when passing through atmosphere of different densities, but are slightly bent into a gentle arc. This phenomenon is called refraction. Refraction is defined as the deviation of light rays from a straight line caused by their passage obliquely through mediums of different density. The measure of refraction is the angular difference between the apparent rays of light from an observed celestial body and its true direction.</p> <p>The effect of refraction is always to make the observed altitude greater than the true altitude. Consequently, refraction correction is always subtracted from the sextant altitude. Since refraction is caused by the oblique passage of rays through the atmosphere, rays from a body in the observer's zenith, intersecting the atmosphere at right angles, are not refracted. Maximum refraction occurs when a body is on the horizon, amounting then to between 34 and 39 minutes of arc. The amount of refractions depends on atmospheric conditions. Density of the atmosphere varies with barometric pressure and temperature. Refraction varies with density and also with the body's altitude. Because refraction varies with atmospheric conditions, and the effect of atmospheric conditions at low altitudes cannot be estimated with complete accuracy, observations of bodies below 10° should be regarded with suspicion. Refraction has no effect on the azimuth of a celestial body because it takes place entirely in the vertical plane of passage of the light rays.</p>
Dip	<p>The higher an observer's position is above the surface of the Earth, the more he/she must lower (or dip) the line of vision to see the horizon. Logically, then, all altitude observations must be corrected for the height of eye. Refer again to figure 9-9, and you will see why a dip correction is always subtracted.</p> <p>Failure to correct for dip from a height of 10 feet will result in an error of 3 miles in a line of position. From the bridge of the average destroyer, the resulting error would be approximately 10 miles.</p>

## Altitude Corrections, Continued

Name	Description
Parallax	<p>Parallax is the difference between the altitude of a body, as measured from Earth's center, and its altitude (corrected for refraction and dip) as measured from Earth's surface. Altitude from the center of Earth is bound to be greater than from the surface. Consequently parallax is always a plus correction.</p> <p>Parallax increases from 0° for a body directly overhead to a maximum for a body on the horizon. In the latter instance, it is called horizontal parallax (HP). Parallax of the Moon is both extreme and varied because of its changing distance from Earth in its passage through its orbit. Parallax of the Sun is small; parallax of the planets is even smaller. For the stars, parallax is so tiny it is negligible.</p>
Semidiameter	<p>The true altitude of a body is measured to the center of that body. Because the Sun and Moon are of appreciable size, the usual practice is to observe the lower limb. Therefore, semidiameter correction must be added. It follows, then, that if the upper limb of either body is observed, the semidiameter correction is subtractive. Semidiameter correction amounts to about 16 minutes of arc for either the Sun or Moon. Stars are considered as points, and they require no semidiameter correction. When observing a planet, the center of the planet is visually estimated by the observer, so there is never a semidiameter correction.</p>

### Remarks

In concluding the subject of altitude corrections, remember that **some tables** for altitude corrections (the *Nautical Almanac*, for example) combine two or more of the corrections for refraction, parallax, and semidiameter.

The correction for height of eye (dip) appears in a separate table for use with all bodies. Index error, which is impossible to include in such tables, should always be determined, recorded, marked plus or minus, and applied before any of the tabulated corrections.

## Altitude Corrections, Continued

### Strip Forms

The OPNAV Strip Form 3530/30; *H.O 229*; *Nautical Almanac* are used to reduce sights for stars, planets, the Sun, and the Moon. The altitude corrections for each are the same except an additional correction is required for the Moon and planets. Reducing sights using this strip form is a process that can be broken down into the following stages:

Stage	Description
1.	Applying altitude corrections to find Ho (height observed).
2.	Using GMT to find LHA to enter Pub 229 with.
3.	Finding True Dee to enter Pub 229 with.
4.	Entering Pub 229 to find total corrections to apply to Ho to find Hc (height computed) Intercept, and Zn.

### Steps to Follow to Find Ho

Use the following table to find Ho for any celestial body. Since we will be working several example problems, refer back to this table to find Ho.

Strip Form Pub 229 Naut Alm	Example problem to find Ho  Action	Complete Strip Form Pub 229 Naut Alm
Body	Enter the symbol of the body.	SUN
GMT	Enter the GMT of the actual sight.	09 15 38
IC	Enter the value of the index correction.	- 1.0
D	Enter the dip correction (height of eye) from the inside cover of the <i>Nautical Almanac</i> .	- 6.9
Sum	Total the IC and D correction.	- 7.9
hs	Enter the uncorrected sextant altitude from the sight.	25° 46.9'
ha	Apply the sum to hs.	25° 39.0'
Alt Corr	Use ha to enter the altitude correction tables of the <i>Nautical Almanac</i> .	+ 14.3'
Add'l Corr Moon Hp/corr	Add any additional corrections for the Moon or planets.	N/A
Ho	Apply altitude and add'l corr to ha.	25° 53.3'

# How to Reduce a Sunline Using Pub 229

---

## Gather Information

As with any celestial observation, you must gather data to reduce to an LOP. With a sextant and recorder you will need the following: date/GMT of sight, DR position, sextant altitude (hs), height of eye of the observer, and IC correction.

---

## Procedure

For our example we will use the following:

Date: 31 March 1984      GMT: 09 15 38  
Lat: 36° 32.8'N      Long: 018° 10.0' W  
hs: 25° 46.9'      IC: - 1.0  
Hgt of Eye: 50 ft

After applying altitude corrections we have determined  $H_o = 25^\circ 53.3'$ .

We can now use the Pub 229 strip form to complete the process of reducing; at this point we have completed stage 1. We can move on to the next stage of finding LHA.

Notice that to find LHA, we follow the same steps as we did for our azimuth of the Sun problem only slightly different. Here's the key difference. We want to arrive at an even number LHA. To do this, we will use an assumed longitude. This step will help us in interpolation later in this problem. There is a catch though; the following rule must be adhered to when finding an assumed longitude.

**Rule:** The assumed longitude used as an assumed position must be within 30' of the original DR longitude.

**Trick of the trade:** When finding your assumed longitude, simply drop the minutes of total GHA down, then add the whole degree of longitude that is within 30' of the DR longitude. Look at our example problem where we dropped the 52.2' down from the total GHA. If we were to use the 18° from the original DR long. of 18° 10.0, which would be 18° 52.2' it would be more than 30', so we changed the 18° to 17° and all's well.

Let's begin working our problem on the next page.



## How to Reduce a Sunline Using Pub 229, Continued

OPNAV 3130/30 Pub 229 Naut Alm	ACTION	Completed Strip Form
Ho	Apply altitude corrections to find.	25° 53.3'
GHA(h)	Enter the GHA hour value from the <i>Nautical Almanac</i> .	313° 57.7'
Increment (m/s)	Enter the minutes and seconds value from the <i>Nautical Almanac</i> .	3° 54.5'
Total GHA	Add GHA(h) and Increments (m/s).	317° 52.2'
v/v corr SHA	ENTER SHA for stars or planets only.	STARS and PLANETS ONLY
<i>a</i> Long (+E, -W) (+ - 360° if needed)	Enter the assumed DR longitude to arrive at an even degree of LHA, add east and subtract west.	17° 52.2'W
LHA	LHA= Total GHA + (v/v or SHA for star and planets) +E or -W DR Long.	300° 00.0'
Tab Dec	Enter the tabulated declination for 07 hours on the Sun column from <i>Nautical Almanac</i> .	N 4° 17.3'
d# / D Corr <sup>n</sup>	<p>The d# is found at the bottom of the Sun Dec column; in this case it is +1.0. It is assigned a + because dec is increasing.</p> <p>The D corr is found on the Increments and Corrections page for 15m38s. Look under the <i>v</i> or <i>d</i> column for the d# (1.0) and record the Corr<sup>n</sup> value (0.4). The D Corr<sup>n</sup> assumes the same sign as the d#.</p>	+0.6 / +0.3'
True Dec	Apply the D Corr <sup>n</sup> to Tab Dec	N 4° 17.6'
DR Lat same or contrary	Enter the whole degree of latitude and determine if it is named (N or S) as True Dec. In this case lat. is N and Dec is N, so it is same.	N 37° same

We have finished stages 2 and 3 and can move on to our final stage.

## How to Reduce a Sunline Using Pub 229, Continued

OPNAV 3130/30 Pub 229 Naut Alm	ACTION	Completed Strip Form
Dec Inc /d	Dec Inc = True Dec min. only / d = d from Pub 229 entered with whole degrees of LHA, Dec, and Lat. (See fig. 9-10.)	17.6 / +38.1
Tens / DSD	Enter from the Pub 229 interpolation tables located on the inside of the front and back cover. (See fig. 9-11.)	+ 8.8
Units / DSD corr	Same as above.	+ 2.4
Total Corr	Total of tens and units.	+ 11.2
Hc (Tab)	Enter from Pub 229.	26° 07.5'
Hc (Comp)	Apply Total Corr to Hc (Tab).	26° 18.7'
Ho	Drop Ho down from the top of the form.	25° 53.3'
a	Subtract the higher value of either Hc(Comp) or Ho from the other. In this case, Ho is subtracted from Hc(Comp).  The A means away. We will fully explain Towards and Away when we plot the LOP.	A 25.4
Z	Enter from Pub 229. Apply the rules for 2 just as with our azimuth problem.	105.8
Zn	LHA is greater than 180 so Zn = Z.	105.8

We have now completed the sight reduction solution for a sunline. The goal was to obtain an LOP. Where is the LOP you ask? Everything we need is right here. We will use the Zn (true bearing), a (intercept), and assumed position to plot our LOP. Let's move on to that task right now.

# How to Reduce a Sunline Using Pub 229, Continued

60°, 300° L.H.A.		LATITUDE SAME NAME AS DECLINATION														N. Lat. { L.H.A. greater than 180°.....Zn=Z L.H.A. less than 180°.....Zn=360°-Z													
Dec.	Hc	30°			32°			33°			34°			35°			36°			37°			Dec.						
		d	Z	M	d	Z	M	d	Z	M	d	Z	M	d	Z	M	d	Z	M										
0	25	39.5	-33.1	106.1	25	05.3	-35.0	107.0	24	47.6	-35.8	107.5	24	29.3	-36.8	107.9	24	10.7	-37.6	108.3	23	51.6	-38.4	108.7	23	32.1	-39.3	109.2	0
1	26	12.6	-32.8	105.2	25	40.3	-34.6	106.1	25	23.6	-35.5	106.6	25	06.1	-36.4	107.0	24	48.3	-37.3	107.5	24	30.0	-38.2	107.9	24	11.4	-39.6	108.3	1
2	26	45.4	-32.4	104.2	26	14.9	-34.3	105.2	25	58.9	-35.2	105.7	25	42.5	-36.1	106.1	25	25.6	-36.9	106.6	25	08.2	-37.8	107.1	24	50.4	-38.7	107.5	2
3	27	17.8	-31.9	103.3	27	04.2	-33.9	104.3	26	34.1	-34.8	104.8	26	18.6	-35.7	105.3	26	02.5	-36.7	105.7	25	46.0	-37.6	106.2	24	20.1	-38.6	107.7	3
4	27	49.7	-31.6	102.3	27	37.1	-33.5	103.4	27	08.9	-34.5	103.9	26	54.0	-35.4	104.4	26	39.2	-36.3	104.8	26	23.6	-37.2	105.3	25	07.5	-38.1	105.8	4
5	28	21.3	-31.3	101.4	28	06.6	-33.1	102.4	27	43.4	-34.1	102.9	27	29.7	-35.1	103.4	27	15.5	-36.0	103.9	27	00.8	-36.9	104.4	26	45.6	-37.8	104.9	5
6	28	52.5	-30.8	100.4	28	39.7	-32.8	101.5	28	17.5	-33.8	102.0	28	04.8	-34.7	102.5	27	51.5	-35.6	103.0	27	37.7	-36.5	103.6	27	23.4	-37.4	104.1	6
7	29	23.3	-30.3	99.4	29	12.5	-32.3	100.5	28	51.3	-33.3	101.1	28	39.5	-34.3	101.6	28	27.1	-35.3	102.1	28	14.2	-36.2	102.7	28	00.8	-37.1	103.2	7
8	29	53.6	-29.9	98.4	29	44.8	-32.0	99.6	29	24.6	-32.9	100.1	29	13.8	-33.9	100.7	29	02.4	-34.9	101.2	28	50.4	-35.9	101.8	28	37.9	-36.8	102.3	8
9	30	23.5	-29.4	97.4	30	16.8	-31.4	98.6	29	57.5	-32.5	99.1	29	47.7	-33.5	99.7	29	37.3	-34.4	100.3	29	26.3	-35.4	100.8	29	14.7	-36.4	101.4	9
10	30	52.9	-28.9	96.4	30	48.2	-31.1	97.8	30	30.0	-32.1	98.2	30	21.2	-33.0	98.8	30	11.7	-34.1	99.3	30	01.7	-35.1	99.9	29	51.1	-36.0	100.5	10
11	31	00.0	-28.2	95.4	31	00.0	-30.2	96.4	31	00.0	-30.3	96.4	31	00.0	-30.3	96.4	31	00.0	-30.3	96.4	31	00.0	-30.3	96.4	31	00.0	-30.3	96.4	11

Figure 9-10. Excerpt from Pub 229.

INTERPOLATION TABLE																	
Dec. Inc.	Altitude Difference (d)										Double Second Diff. and Corr.						
	Tens					Decimals				Units							
	10'	20'	30'	40'	50'	0	1	2	3	4		5	6	7	8	9	
16.0	2.6	5.3	8.0	10.6	13.3	0	0.0	0.3	0.5	0.8	1.1	1.4	1.6	1.9	2.2	2.5	
16.1	2.7	5.3	8.0	10.7	13.4	.1	0.0	0.3	0.6	0.9	1.1	1.4	1.7	2.0	2.2	2.5	
16.2	2.7	5.4	8.1	10.8	13.5	.2	0.1	0.3	0.6	0.9	1.2	1.4	1.7	2.0	2.3	2.5	1.0
16.3	2.7	5.4	8.1	10.9	13.6	.3	0.1	0.4	0.6	0.9	1.2	1.5	1.7	2.0	2.3	2.6	3.0
16.4	2.7	5.5	8.2	10.9	13.7	.4	0.1	0.4	0.7	0.9	1.2	1.5	1.8	2.0	2.3	2.6	4.9
16.5	2.8	5.5	8.3	11.0	13.8	.5	0.1	0.4	0.7	1.0	1.2	1.5	1.8	2.1	2.3	2.6	6.9
16.6	2.8	5.5	8.3	11.1	13.8	.6	0.2	0.4	0.7	1.0	1.3	1.5	1.8	2.1	2.4	2.6	8.9
16.7	2.8	5.6	8.4	11.2	13.9	.7	0.2	0.5	0.7	1.0	1.3	1.6	1.8	2.1	2.4	2.7	10.8
16.8	2.8	5.6	8.4	11.2	14.0	.8	0.2	0.5	0.8	1.0	1.3	1.6	1.9	2.1	2.4	2.7	12.8
16.9	2.9	5.7	8.5	11.3	14.1	.9	0.2	0.5	0.8	1.1	1.3	1.6	1.9	2.2	2.4	2.7	14.8
17.0	2.8	5.6	8.5	11.3	14.1	0	0.0	0.3	0.6	0.9	1.2	1.5	1.7	2.0	2.3	2.6	16.7
17.1	2.8	5.7	8.5	11.4	14.2	.1	0.0	0.3	0.6	0.9	1.2	1.5	1.8	2.1	2.4	2.7	18.7
17.2	2.8	5.7	8.6	11.4	14.3	.2	0.1	0.3	0.6	0.9	1.2	1.5	1.8	2.1	2.4	2.7	20.7
17.3	2.9	5.8	8.6	11.5	14.4	.3	0.1	0.4	0.7	1.0	1.3	1.5	1.8	2.1	2.4	2.7	22.7
17.4	2.9	5.8	8.7	11.6	14.5	.4	0.1	0.4	0.7	1.0	1.3	1.6	1.9	2.2	2.4	2.7	24.6
17.5	2.9	5.8	8.8	11.7	14.6	.5	0.1	0.4	0.7	1.0	1.3	1.6	1.9	2.2	2.5	2.8	26.6
17.6	2.9	5.9	8.8	11.7	14.7	.6	0.2	0.5	0.8	1.0	1.3	1.6	1.9	2.2	2.5	2.8	28.6
17.7	3.0	5.9	8.9	11.8	14.8	.7	0.2	0.5	0.8	1.1	1.4	1.7	2.0	2.2	2.5	2.8	30.5
17.8	3.0	6.0	8.9	11.9	14.9	.8	0.2	0.5	0.8	1.1	1.4	1.7	2.0	2.3	2.6	2.9	32.5
17.9	3.0	6.0	9.0	12.0	15.0	.9	0.3	0.6	0.8	1.1	1.4	1.7	2.0	2.3	2.6	2.9	34.5
18.0	3.9	7.8	11.8	15.0	19.6	.5	0.2	0.6	1.0	1.4	1.8	2.2	2.6	2.9	3.3	3.7	27.9
23.6	3.9	7.9	11.8	15.7	19.7	.6	0.2	0.6	1.0	1.4	1.8	2.2	2.6	3.0	3.4	3.8	29.6
23.7	4.0	7.9	11.9	15.8	19.8	.7	0.3	0.7	1.1	1.4	1.8	2.2	2.6	3.0	3.4	3.8	31.3
23.8	4.0	8.0	11.9	15.9	19.9	.8	0.3	0.7	1.1	1.5	1.9	2.3	2.7	3.1	3.4	3.8	33.0
23.9	4.0	8.0	12.0	16.0	20.0	.9	0.4	0.7	1.1	1.5	1.9	2.3	2.7	3.1	3.5	3.9	34.7

Figure 9-11. Interpolation table from the inside cover of Pub 229.

# Plotting One or More LOPs

## Procedure

Follow the steps in the table and refer to the accompanying figures to plot LOPs.

Step	Action
1.	Plot the AP (assumed position). This is the whole degree of latitude and the assumed longitude. In our example problem this would be Lat $37^{\circ} 00.0' N$ Long $017^{\circ} 52.2' W$ .
2.	Lay off the azimuth line ( $Z_n$ ) from the AP toward or away from the body, depending on whether the observed altitude ( $H_o$ ) is greater or less than the computed altitude ( $H_c$ ).
3.	Measure in the proper direction, along the azimuth line, the difference between the observed and the computed altitude in miles and tenths of miles. This is the value of $a$ or intercept.
4.	Draw a line at the extremity of $a$ , perpendicular (add $90^{\circ}$ to $Z_n$ ) to the azimuth line. At the time of observation, this perpendicular line is the LOP.
5.	Label the LOP with the time of observation and the name of the observed body.

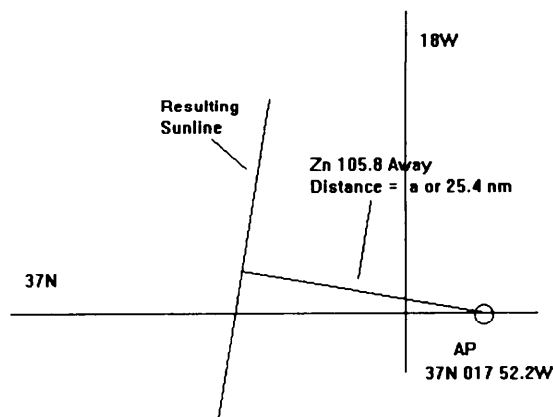

Figure 9-12. Plot the LOP.

# Advancing LOPs

---

## Advancing LOPs

Several methods may be used to advance a LOP. The most common method consists simply of advancing the AP in the direction of and for the distance of the run, as shown in figure 9-13, and drawing the new LOP.

Figure 9-13 illustrates a situation where the AP was advanced parallel to the course line for the distance run, and a new LOP was plotted from its new position. The new LOP was necessary because the same AP would have produced an LOP that would have intersected the course line beyond the limits of the chart. In this illustrative case, it is unnecessary to draw the first dashed construction on the chart.

The manner of advancing LOP from sights of the Moon, Venus, and Sirius (previously illustrated) to obtain an 1815 fix is seen in figure 9-14.

## Advancing LOPs, Continued

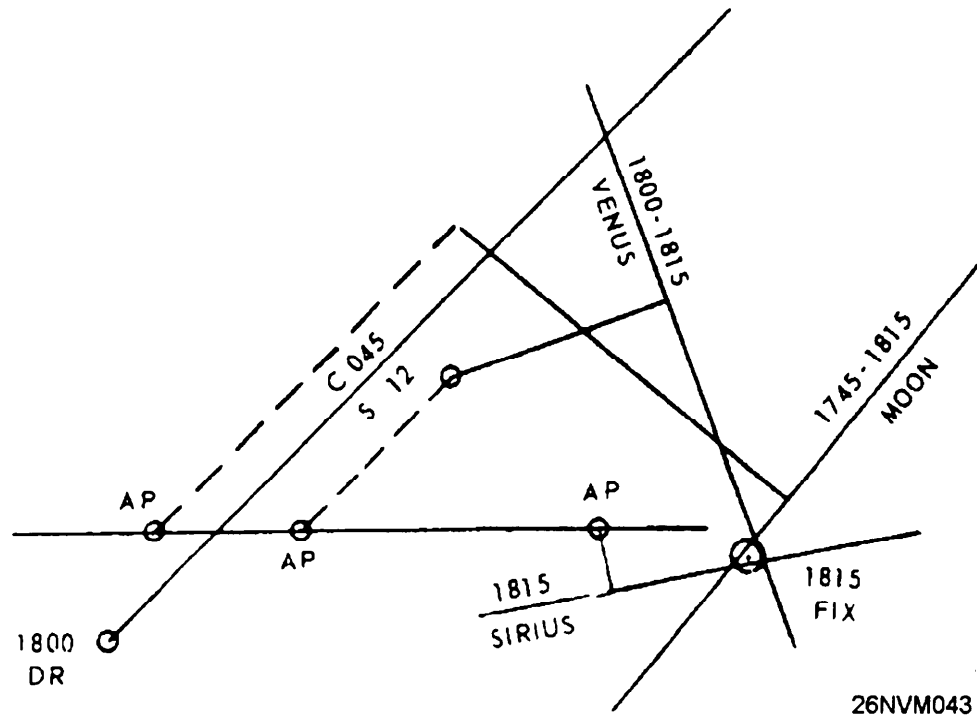

Figure 9-14. A fix from several LOPs.

Three lines of position by observation, like those obtained in piloting, do not always intersect exactly. Quite often a triangle is formed. If one or more of the LOPs must be advanced, the triangle is likely to be larger. Frequently, the center of the triangle is assumed to be the fix.

If, however, one or more lines have been advanced, more weight may be given to a line that has not been advanced, or to a line that the navigator has more confidence in; for example, favoring a first magnitude star over a third magnitude star. In figure 9-14, note that the plots are made from three separate APs, using the same assumed latitude but different assumed longitudes.

# Reducing Stars, Planets, and the Moon Using Pub 229

---

## **Procedure for Stars and Planets**

The steps to follow to reduce stars and planets are nearly the same steps that we used to reduce our sunline. The only differences are that in both cases when finding LHA, we must add the value of sidereal hour angle (SHA) to the total GHA to find LHA. Also, in the altitude correction tables for stars and planets there is an additional correction listed for some planets that must be added.

---

## **Procedure for the Moon**

Once again the steps for the Moon are the same as our sunline except that the  $v$  and HP corrections must be added. These are additional altitude corrections. The  $v$  correction is always +. The HP correction for the nearest whole hour of GMT is selected. The  $v$  correction is found on the appropriate increments minutes and seconds page in the same manner as the  $d$  correction. If the upper limb of the Moon is observed, an additional correction (Add'l Corr) of -30' is made.

## Reducing Sights Using Pub 249

### General

HO Pub 249, *Sight Reduction Tables for Air Navigation* and the *Air Almanac*, can also be used to reduce sights. This method of sight reduction is used by some navigators; however, the degree of accuracy is slightly less than sight reduction by Pub 229.

### Procedure

Once again, you would have to gather information to reduce; that is, GMT, sextant altitude, and so on.

For our example problem, we will use the following data:

Date: 30 March 1985      GMT: 06 26 21  
 Lat: 36° 40.1'N      Long: 017° 31.6' W  
 hs: 40° 33.6'      IC: + 0.8  
 Hgt of Eye: 50 ft

OPNAV 3130/32 H.O.249 Air Alm	ACTION	Completed Strip Form
Body	Enter the name of the body.	REGULUS
GMT	Enter time of sight.	06h 26m 21s
IC	Enter the index correction.	+ 0.8
D	Enter the dip correction (hgt of eye 50ft) using the altitude correction table from the <i>Air Almanac</i> . (See fig. 9-16.)	- 7.0
R <i>o</i>	This is the refraction correction from the <i>Air Almanac</i> . (See fig. 9-17.)	- 1.0
SD		
ha		
Total Corr (sum)	Total of IC, D, and R <i>o</i> .	- 7.2
hs	Enter the sextant altitude.	40° 33.6'
Ho	Apply altitude corrections to find.	40° 26.4'



# Reducing Sights Using Pub 249, Continued

CORRECTIONS TO BE APPLIED TO MARINE SEXTANT ALTITUDES									
CORRECTION FOR DIP OF THE HORIZON									
To be subtracted from sextant altitude									
Ht.	Dip	Ht.	Dip	Ht.	Dip	Ht.	Dip	Ht.	Dip
Ft.		Ft.		Ft.		Ft.		Ft.	
0		114		437		968		1 707	
2	1	137	11	481	21	1 033	31	1 792	41
6	2	162	12	527	22	1 099	32	1 880	42
12	3	189	13	575	23	1 168	33	1 970	43
21	4	218	14	625	24	1 239	34	2 061	44
31	5	250	15	677	25	1 311	35	2 155	45
43	6	283	16	731	26	1 386	36	2 251	46
58	7	318	17	787	27	1 463	37	2 349	47
75	8	356	18	845	28	1 543	38	2 449	48
93	9	395	19	906	29	1 624	39	2 551	49
114	10	437	20	968	30	1 707	40	2 655	50

26NVM048

Figure 9-16. Marine sextant altitude correction from the *Air Almanac*.

## CORRECTIONS TO BE APPLIED TO SEXTANT ALTITUDE REFRACTION

To be subtracted from sextant altitude (referred to as observed altitude in A.P. 3270)

R <sub>o</sub>	Height above sea level in units of 1000 ft.												R <sub>o</sub>
	0	5	10	15	20	25	30	35	40	45	50	55	
Sextant Altitude													
	0	0	0	0	0	0	0	0	0	0	0	0	0
0	90	90	90	90	90	90	90	90	90	90	90	90	0
1	63	59	55	51	46	41	36	31	26	20	17	13	1
2	33	29	26	22	19	16	14	11	9	7	6	4	2
3	21	19	16	14	12	10	8	7	5	4	2 40	1 40	3
4	16	14	12	10	8	7	6	5	3 10	2 20	1 30	0 40	4
5	12	11	9	8	7	5	4 00	3 10	2 10	1 30	0 39	+0 05	5
6	10	9	7	5 50	4 50	3 50	3 10	2 20	1 30	0 49	+0 11	-0 19	6
7	8 10	6 50	5 50	4 50	4 00	3 00	2 20	1 50	1 10	0 24	-0 11	-0 38	7
8	6 50	5 50	5 00	4 00	3 10	2 30	1 50	1 20	0 38	+0 04	-0 28	-0 54	8
9	6 00	5 10	4 10	3 20	2 40	2 00	1 30	1 00	0 19	-0 13	-0 42	-1 08	

26NVM049

Figure 9-17. Excerpt from refraction correction tables of the *Air Almanac*.

# Reducing Sights Using Pub 249 , Continued

**(DAY 089) GREENWICH A. M. 1985 MARCH 30 (SATURDAY)**

GMT (UT)	☉ SUN		♈ ARIES		♀ VENUS-4.1		♃ JUPITER-2.1		♄ SATURN 0.3		☾ MOON		Lat.	Moon-rise	Diff.
	GHA	Dec.	GHA <sup>h</sup>	<sup>m</sup> Dec.	GHA	Dec.	GHA	Dec.	GHA	Dec.	GHA	Dec.			
00 00	178 50.2	N 3 39.7	187 19.5		174 44 N14 10		234 09 S17 59		311 20 S17 24		82 38 N26 59				
10	181 20.3	39.9	189 49.9		177 14		236 39		313 51		85 03	59			
20	183 50.3	40.1	192 20.3		179 45		239 10		316 21		87 27	59	72	0	*
30	186 20.3	40.2	194 50.7		182 16		241 40		318 52		89 52	59	68	0	*
40	188 50.4	40.4	197 21.1		184 46		244 10		321 22		92 16	58	66	0	*
50	191 20.4	40.5	199 51.5		187 17		246 41		323 52		94 40	58	64	0	*
05 00	253 51.2	N 3 44.6	262 31.8		250 03 N14 07		309 19 S17 59		26 33 S17 23		154 50 N26 50		56	16 15	19
10	256 21.2	44.7	265 02.2		252 33		311 50		29 04		157 15	49	58	16 36	17
20	258 51.2	44.9	267 32.6		255 04		314 20		31 34		159 39	49	60	17 03	14
30	261 21.3	45.1	270 03.0		257 35		316 50		34 04		162 03	48			
40	263 51.3	45.2	272 33.5		260 05		319 21		36 35		164 28	48	S		
50	266 21.3	45.4	275 03.9		262 36		321 51		39 05		166 52	48			
06 00	268 51.4	N 3 45.6	277 34.3		265 06 N14 06		324 21 S17 59		41 36 S17 23		169 17 N26 47		Moon's P. in A.		
10	271 21.4	45.7	280 04.7		267 37		326 52		44 06		171 41	47	A	C	+
20	273 51.4	45.9	282 35.1		270 08		329 22		46 36		174 05	46	t	r	r
30	276 21.5	46.0	285 05.5		272 38		331 52		49 07		176 30	46			
40	278 51.5	46.2	287 35.9		275 09		334 23		51 37		178 54	46	0	+	+
50	281 21.5	46.4	290 06.3		277 40		336 53		54 08		181 18	45	5	57	55
07 00	283 51.6	N 3 46.5	292 36.7		280 10 N14 06		339 23 S17 59		56 38 S17 23		183 43 N26 45		5	56	56
10	286 21.6	46.7	295 07.1		282 41		341 54		59 09		186 07	44	12	56	57
20	288 51.6	46.9	297 37.6		285 11		344 24		61 39		188 32	44	16	55	58
30	291 21.7	47.0	300 08.0		287 42		346 54		64 10		190 56	43	19	54	59
40	293 51.7	47.2	302 38.4		290 13		349 25		66 40		193 20	43	22	53	61
50	296 21.7	47.3	305 08.8		292 43		351 55		69 10		195 45	42	24	52	62
11 00	343 52.3	N 3 50.4	352 46.6		340 25 N14 03		39 31 S17 58		116 48 S17 23		241 28 N26 33		53	33	
10	346 22.3	50.6	355 17.0		342 56		42 02		119 19		243 52	32	55	32	
20	348 52.4	50.7	357 47.4		345 27		44 32		121 49		246 16	32	56		
30	351 22.4	50.9	0 17.8		347 57		47 02		124 20		248 41	31	Sun SD 16.0		
40	353 52.4	51.1	2 48.2		350 28		49 33		126 50		251 05	31	Moon SD 15'		
50	356 22.5	51.2	5 18.6		352 59		52 03		129 21		253 30	30	Age 9d		
Rate	15 00.2	N0 01.0			15 03.8	S0 00.7	15 02.0	N0 00.1	15 02.6	0 00.0	14 26.3	S0 02.5*			

Figure 9-18. Excerpt from the daily pages of the *Air Almanac*.

## LAT 37°N

LHA	Hc	Zn	Hc	Zn	Hc	Zn	Hc	Zn	Hc	Zn	Hc	Zn	Hc	Zn
180	16 15 053	44 14 087	55 52 112	38 11 154	54 27 233	36 10 280	18 48 314							
181	16 54 054	45 02 087	56 36 113	38 32 155	53 48 234	35 23 281	18 13 314							
182	17 33 054	45 49 088	57 20 114	38 52 156	53 09 236	34 36 281	17 39 315							
183	18 12 055	46 37 089	58 04 115	39 11 157	52 29 237	33 49 282	17 05 315							
184	18 51 055	47 25 089	58 47 116	39 29 158	51 49 238	33 02 282	16 32 316							
185	19 30 056	48 13 090	59 30 118	39 46 160	51 08 239	32 15 283	15 58 316							
186	20 10 056	49 01 090	60 12 119	40 02 161	50 27 240	31 28 283	15 25 317							
187	20 50 057	49 49 091	60 54 120	40 17 162	49 45 241	30 42 284	14 53 317							
188	21 30 057	50 37 092	61 35 121	40 32 163	49 03 242	29 55 284	14 20 318							
189	22 10 057	51 25 092	62 16 123	40 45 165	48 20 243	29 09 285	13 48 318							
190	22 51 058	52 13 093	62 56 124	40 57 166	47 37 244	28 23 285	13 16 318							
191	23 31 058	53 01 094	63 35 126	41 08 167	46 54 245	27 37 286	12 44 319							
192	24 12 059	53 48 094	64 13 127	41 18 169	46 10 246	26 51 286	12 13 319							
193	24 53 059	54 36 095	64 51 129	41 28 170	45 26 247	26 05 287	11 42 320							
194	25 34 059	55 24 096	65 28 131	41 36 171	44 42 248	25 19 287	11 11 320							
255	48 32 061	42 31 116	21 18 153	26 11 188	49 49 256	53 17 306	49 39 347							
256	49 13 061	43 14 117	21 40 154	26 03 189	49 03 256	52 38 306	49 28 347							
257	49 55 061	43 57 118	22 00 155	25 55 190	48 16 257	51 59 306	49 17 347							
258	50 37 061	44 39 119	22 21 156	25 47 191	47 29 258	51 20 306	49 05 346							
259	51 19 061	45 21 120	22 40 157	25 37 192	46 42 259	50 41 306	48 54 346							
260	52 01 061	46 03 121	22 59 157	25 26 193	45 55 260	50 02 306	48 42 346							
261	52 44 062	46 44 122	23 17 158	25 15 194	45 08 260	49 23 306	48 30 345							
262	53 26 062	47 25 123	23 34 159	25 03 195	44 21 261	48 44 306	48 18 345							
263	54 08 062	48 05 124	23 51 160	24 50 196	43 33 262	48 05 306	48 05 345							
264	54 50 062	48 44 125	24 07 161	24 37 197	42 46 262	47 27 306	47 53 345							
265	55 32 062	49 24 126	24 22 162	24 22 198	41 58 263	46 48 306	47 40 344							
266	56 15 062	50 02 127	24 36 163	24 07 199	41 11 264	46 09 306	47 27 344							
267	56 57 062	50 40 128	24 50 164	23 52 200	40 23 264	45 30 306	47 14 344							
268	57 39 062	51 17 130	25 03 165	23 35 201	39 35 265	44 52 306	47 00 344							
269	58 22 062	51 54 131	25 15 166	23 18 202	38 47 266	44 13 307	46 46 343							

Figure 9-19. Excerpt from Pub 249, Volume I.

## Reducing Sights Using Pub 249, Continued

OPNAV 3130/32 H.O.249 Air Alm	ACTION	Completed Strip Form
GHA(h)	Enter the GHA hour value of Aries from the <i>Air Almanac</i> to the nearest 10 minutes. (See fig. 9-18).	282° 35.1'
Increment (m/s)	Enter the minutes and seconds value from the interpolation tables of the <i>Air Almanac</i> .	1° 35.5'
Total GHA	Add GHA(h) and Increments (m/s).	284° 10.6'
+ - 360 (if needed)		
a Long (+E, -W)	Enter the assumed DR longitude to arrive at an even degree of LHA, add east and subtract west.	17° 10.6'W
LHA	LHA= Total GHA + (v/v or SHA for stars and planets) +E or -W DR Long.	267° 00.0'
a LAT	Enter the assumed latitude.	37°N
Hc	Enter Pub 249 volume I, with the whole degree of LHA for REGULUS, record Hc and Zn (last block). (See fig. 9-19.)	40° 23.0'
Ho	Drop down Ho from above.	40° 26.4'
a	Find the difference between Hc and Ho (remember to use Ho MO To). In this example, Ho is more than Hc, so it's named T for towards.	T 3.4'
Zn	Enter the Zn (true bearing).	264°

As you can see, using Pub 249 to determine a celestial LOP is a quick process compared to using Pub 229. Keep in mind that some amount of accuracy is lost.

## Latitude by Local Apparent Noon (LAN)

### Time of Meridian Passage

The purpose of knowing ahead of time the exact time of meridian passage (the Sun directly overhead) of the Sun is to allow the observer and recorder to arrive on the bridge a few minutes early. A latitude line from LAN is very useful. It is often used along with two morning sunlines to establish a noon celestial running fix. We will again be using a strip form to complete our sight reduction. First, we will find the time of meridian passage, then we will work the LAN solution. For our example problem, we will use the following data: Date: 30 March 84, DR Lat: 36°36.1'N, DR Long: 19° 22.3'W.

OPNAV 3130/35 LAN	ACTION		Completed Strip Form
DR Long	Enter the DR longitude.		19° 22.3'W
STD Meridian	Enter the standard meridian.		15
d long (arc)	Find the difference between STD Mer and DR Long.		4° 22.3'
d long (time)	Convert arc to time using the arc to time page in the <i>Nautical Almanac</i> .		+ 17 Min
LMT Mer Pass	From the daily pages in the <i>Nautical Almanac</i> for the given date, enter the time of meridian passage (bottom right of page).		1204
ZT LAN (1st est.)	<b>IF...</b>	<b>THEN...</b>	1221
	west of the standard meridian	Add d long (time) to LMT Mer Pass.	
	east of the standard meridian	Subtract d long (time) from LMT Mer Pass.	
Rev.DR Long	Enter revised DR.		19° 22.3'W
STD Meridian	Enter the standard meridian.		15
d long (arc)	Find the difference between STD Mer and DR Long.		4° 40.0'
d long (time)	Convert arc to time.		+19
LMT Mer Pass	Enter LMT for Mer Pass.		1204
ZT LAN (2nd est)	Add time to LMT Mer Pass.		1223

## Latitude by Local Apparent Noon (LAN), Continued

---

**Taking Sights to Observe LAN** Up to this point we have learned how to find the time that the Sun should be directly overhead. Now we need to know how to observe LAN. We will discuss two methods. The first is called following to maximum altitude; the second is called *numerous sights*.

---

**Following to Maximum Altitude** The oldest method of determining meridian altitude of the Sun, and the one used most commonly, is known as following to maximum altitude. It is recommended because of its adaptability to various conditions, and because its use develops an insight into how the altitude varies near the time of apparent noon.

At approximately 10 minutes before watch time of LAN, the observer contacts the Sun's lower limb with the horizon in the sextant. He/she then swings the sextant from side to side, and adjusts it until the Sun, seen moving in an arc, just touches the horizon at the lowest part of the arc. This procedure is known as swinging the arc, which was described earlier in this chapter.

As the Sun continues rising, a widening space appears between its lower limb and the horizon. By turning the micrometer drum, the observer keeps this space closed and maintains the Sun in contact with the horizon. The change in altitude becomes slower and slower, until the Sun "hangs". While it is hanging, the observer swings the sextant to make certain of accurate contact with the horizon. He/she continues the observations until the Sun dips, which is a signal that the Sun is beginning to lose altitude. The sextant then shows the maximum altitude attained.

## Latitude by Local Apparent Noon (LAN), Continued

---

### **Numerous Sights**

The method of taking numerous sights is a modification of the maximum altitude method. It is useful under conditions where heavy seas, clouds, and the like may make steady observation impossible. Well before watch time of LAN, the observer begins taking a series of altitudes. Their number depends on the difficulties of the situation and the possible error in computed time of transit. He/she reads off the altitudes to a recording assistant, turning the tangent screw slightly after each observation to make sure that the next altitude is an independent sight. Observations are discontinued when the altitude definitely shows signs of decreasing.

Under favorable conditions, even a series of skillfully taken observations may show an occasional erratic deviation from the normal gradual rise and fall. After sights showing a radical difference from the preceding or succeeding series are discarded, however, the hang should become evident, and it should be possible to judge the maximum altitude. The figure selected will probably be less than the altitude shown in one observation and more than that below it. The result should give latitude with an error no more than 1'. This reading is considerably more accurate than could be obtained by a single sight under the conditions described.

### **Finding Latitude**

As you now know, you must first obtain a sight of the Sun when it's at maximum altitude and the time of observation. With this and a DR position, we can reduce the sight to find latitude; now we can work the second part of our strip form.

# Latitude by Local Apparent Noon (LAN), Continued

OPNAV 3130/35 LAN	ACTION	Completed Strip Form
LAT by LAN		
ZT LAN (obs)	Enter the ZT of the observation.	1221
ZD	Enter the zone description.	+ 1
GMT	Convert ZT to GMT.	1321
Tab Dec	Enter the tabulated declination for the Sun from the <i>Nautical Almanac</i> .	N 3° 57.9'
d# / d Corr	Enter the d# from the bottom of the Sun column, remember to find out if dec is + (increasing) or - (decreasing). Find the d Corr from the increments minutes and seconds pages for 21 minutes.	+ 1.0 / + 0.4
True Dec	Apply the d Corr to Tab Dec	N 3° 58.3'
IC	Enter the index correction.	+ 1.2
D	Enter the dip correction.	- 6.9
Sum	Enter the total of the IC and D.	- 5.7
Hs	Enter the uncorrected sextant altitude.	57 16.4
Ha	Apply the sum of the IC and dip corrections.	57 10.7
Alt Corr	Enter the altitude correction from the inside cover of the <i>Nautical Almanac</i> .	+ 15.6
Ho	Apply the Alt Corr to Ha.	57 26.3

## Latitude by Local Apparent Noon (LAN), Continued

OPNAV 3130/35 LAN	ACTION	Completed Strip Form								
89° 60'	Enter 89° 60.0'.	89° 60.0								
HO (-)	Enter Ho.	57° 26.3								
Z Dist	Subtract Ho from 89 60.0.	32° 33.7'								
True Dec	Enter True Dec.	N 3° 58.3								
Lat	Use the following rules for making the declination correction: <table border="1" data-bbox="553 634 1153 995"> <thead> <tr> <th>IF...</th> <th>THEN...</th> </tr> </thead> <tbody> <tr> <td>Lat and Dec are of different names</td> <td>Lat = Z dist - Dec</td> </tr> <tr> <td>Lat and Dec are of same names <b>and</b> Lat is less than Dec</td> <td>Lat = Dec - Z dist</td> </tr> <tr> <td>Lat and Dec are of same names <b>and</b> Lat is greater than Dec</td> <td>Lat = Z dist + Dec</td> </tr> </tbody> </table>	IF...	THEN...	Lat and Dec are of different names	Lat = Z dist - Dec	Lat and Dec are of same names <b>and</b> Lat is less than Dec	Lat = Dec - Z dist	Lat and Dec are of same names <b>and</b> Lat is greater than Dec	Lat = Z dist + Dec	36° 32.0'
IF...	THEN...									
Lat and Dec are of different names	Lat = Z dist - Dec									
Lat and Dec are of same names <b>and</b> Lat is less than Dec	Lat = Dec - Z dist									
Lat and Dec are of same names <b>and</b> Lat is greater than Dec	Lat = Z dist + Dec									
Time		12h 21m 00s								

### Closing Remarks

Celestial navigation requires skill gained through experience. This chapter has given you the basic knowledge required to meet the minimum requirements of the Quartermaster occupational standards. This is just the tip of the iceberg; you should strive to perfect your celestial skills. In the event of a large scale war, you may find that all electronic means of obtaining a fix have been knocked out. It's important that electronic fixes are compared to celestial fixes whenever possible. Remember, the prudent navigator uses all available means to accurately fix the ship's position along the intended track.

Quartermasters should study sources other than this RTM to gain additional knowledge on celestial navigation. *Dutton's Navigation and Piloting* is an excellent reference on this material.



# Chapter 10

## Weather Observation

---

### Introduction

The people who "go down to the sea in ships" fight a continuous close battle with the elements that make up the weather. A mariner's watch of weather conditions is of greater importance than it is to most people ashore. Accurate weather forecasting may not be as vital now as it was in the days of the sailing ships, but situations still arise when the safety of a ship and the lives of its crew depend on the evasive action taken to avoid the full fury of a storm. Even when actual safety is not considered, possible damage to the ship's boats and gear must be minimized by extra security measures taken well in advance of an approaching storm.

The action taken by ships may be based on the latest weather information compiled and broadcast by the appropriate Naval Oceanographic Center. The oceanographic centers base their predictions largely upon the reports of weather conditions received from ships at sea. An intelligent weather report from a ship can be made only by a person capable of accurately observing and (to some extent) interpreting weather conditions. Aerographer's mates are charged with this duty, but not all ships carry them. On a ship that doesn't have an Aerographer's Mate aboard, the weather observation duties are the responsibility of the Quartermasters. This chapter, then, is concerned with the weather and the way it is observed and reported.

---

### Objectives

The material in this chapter will enable the student to:

- Measure, convert, and record barometric pressure.
- Determine apparent wind, relative wind, and true wind using anemometers or visual estimation.
- Identify cloud types and match them with their correct heights.
- Measure temperature, dew point, and relative humidity.
- Convert temperature to Celsius or Fahrenheit.
- Observe and report weather conditions using form CNOG 3140/8.
- Describe weather conditions associated with fronts.
- Recommend course of action to evade storms.

# Topics

---

<b>Topic</b>	<b>Page</b>
The Atmosphere	10-3
Circulation of the Wind Upon Earth	10-4
Cloud Formations	10-6
Cloud Characteristics	10-8
Atmospheric Pressure	10-11
Pressure Areas	10-13
Frontal Systems	10-15
Wind	10-19
Temperature, Dew Point, and Relative Humidity	10-26
Weather Observation and Reporting	10-30

# The Atmosphere

---

## **Composition**

The atmosphere (air) is a mixture of independent gases. Near the surface of Earth, the percentages by volume of the various constituents are approximately 78% nitrogen, 21% oxygen, 1% argon, and traces of other gases such as carbon dioxide, hydrogen, neon, and helium. Water vapor, which has been omitted from the foregoing list, is found in relatively small but widely varying amounts; 1% of the total atmosphere may be taken as the average figure. The quantity of water vapor present is much greater in equatorial regions than it is in polar regions and greater over the ocean than over land. The atmosphere has definite weight, called atmospheric pressure, and is measured by an instrument called a barometer.

---

## **Changes in the Weather**

Large-scale changes in temperature, pressure, and water vapor content of the atmosphere cause changes in the weather. Warm air is lighter in weight and can hold more water vapor than cold air. Moist air with a temperature of 50°F is lighter than drier air of the same temperature because water vapor is lighter than air. Cold or heavy air has a tendency to flow toward and take the place of warm or lighter air; and, as the air begins to move, other forces come in to play, making the movement of air masses and weather rather complex. You can readily see that temperature, humidity, and atmospheric pressure are all factors in considering the weather.

# Circulation of the Wind Upon Earth

## The Basics

The following paragraphs deal with the general (surface) circulation with prevailing winds and nearby permanent pressure systems of belts. (See fig. 10-1). In the Northern Hemisphere, the circulation is clockwise about high-pressure areas (called anticyclones) and counterclockwise about low-pressure areas (called cyclones). The reverse is true in the Southern Hemisphere. At times, confusion arises from the meaning of wind direction. Wind is always named by the direction *from* which it is blowing.

## The Doldrums

The equatorial belt of light and variable winds between the northeast tradewinds of the Northern Hemisphere and the southeast trade winds of the Southern Hemisphere is called the doldrums, or the intertropical convergence zone.

The doldrums may vary in position. They tend to move north and south of the Equator with the Sun, though more of the area is generally located slightly north of the Equator. In the doldrums, the temperatures are high and the wind convergent (a net inflow of air into the area), which causes greater rainfall.

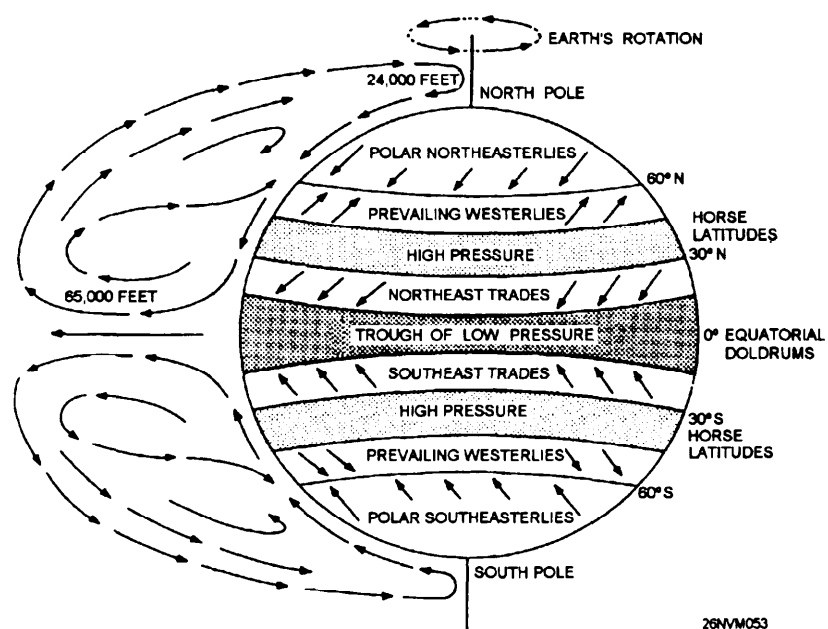

Figure 10-1. General circulation of air.

## Circulation of the Wind Upon Earth, Continued

---

**The Tradewinds** The tradewinds are found just north and south of the doldrums. Whenever the doldrums are absent in some part of the equatorial region, the tradewinds of the Northern and Southern Hemispheres converge, causing heavy rain squalls. A feature of the trade belt is the regularity of the systems, especially over the oceans. The wind blowing above and counter to the trade is called the *ANTITRADE*.

---

**Horse Latitudes** The areas of the subtropical high-pressure cells, where the winds are light and variable are about 30°N to 40°N and 30°S to 40°S. They are called the *horse* latitudes. Fair weather is characteristic of this region, due to the descending air. The pressure decreases outward from this area, and the prevailing westerlies are on the poleward side, with the tradewinds on the equatorial side.

---

**Prevailing Westerlies** The *prevailing westerlies*, which are on the poleward side of the tradewinds are persistent through the midlatitudes. In the Northern Hemisphere their direction at the surface is from the southwest, and in the Southern Hemisphere from the northwest. This is a result of the deflection caused by the Coriolis force as air moves poleward. The Coriolis effect is the apparent force exerted by the rotation of Earth. The front zone lies poleward of the prevailing westerlies.

---

**Polar Region Winds** In the polar cells, polewards of the polar front zone, the surface winds are known as the polar easterlies (polar northeasterlies at the North Pole and southeasterlies at the South Pole). They move the northeast in the Northern Hemisphere and from the southeast in the Southern Hemisphere. They are very shallow due to the low temperatures and are overlain by the westerlies. This circulation pattern is temporarily disrupted by the migratory pressure systems in all areas but returns to the original pattern.

# Cloud Formations

---

## The Basics

The atmosphere always contains, in greater or smaller amounts, tiny particles, such as dust from roads, desert sand, plant pollen, salt particles from oceans, and factory smoke. These fragments are hygroscopic nuclei, the term means particles that readily condense moisture. A cloud is merely a mass of hygroscopic nuclei that has soaked up moisture from the air.

The heat generated by the Sun's energy causes earthbound moisture to evaporate (turn into water vapor). Water vapor is lighter than air; thus, it rises. If the air it passes into is cold enough, the vapor condenses; that is, it turns back into moisture. The water droplets that result from this process cling to the hygroscopic nuclei. Many of these water-soaked nuclei bunched together form a cloud. Fog is the same in principle, but it's a cloud on the ground.

Changes in atmospheric conditions account for the many different shapes of clouds and for their presence at various altitudes. Formations of clouds give clues concerning the existing forces at play in the atmosphere. That's why you must keep an accurate record of cloud genera (types).

---

## Cloud Etage

With respect to clouds, the atmosphere is broken down into three layers or *etages*. In the middle latitudes or temperate region, the low etage is from the surface to 6,500 feet; the mid etage, from 6,500 feet to 18,500 feet; and the high etage, from 18,500 feet on up to near 45,000 feet (fig. 10-2). The limits of the etages are generally lower in the polar regions (mid etage, from 6,500 to 10,000 feet and high etage from 10,000 to 25,000 feet) and higher in the tropics (mid etage from 6,500 to 20,000 feet and high etage from 20,000 to 60,000 feet).

The low-etage cloud may be cumuliform, such as the cumulus genera or cumulonimbus (identified by their size and extent of development); stratiform, such as the stratus; or have mixed characteristics, such as the stratocumulus. The mid-etage cloud genera are mostly identified with the prefix *alto*. The mid etage contains the cumuliform clouds, such as altocumulus, and the stratiform clouds, such as altostratus and nimbostratus. The high-etage cloud genera contain the prefix *cirro*. Cumuliform clouds in this etage are called cirrocumulus, while stratiform clouds are called cirrostratus. Another form of cloud found only in the high etage is the cirriform clouds that are the normally thin, wispy or hairlike ice-crystal clouds that can be defined as neither cumuliform nor stratiform, but are simply called cirrus clouds.

Take a moment to study figure 10-2, which shows many of the cloud genera and their associated heights above ground.

# Cloud Formations, Continued

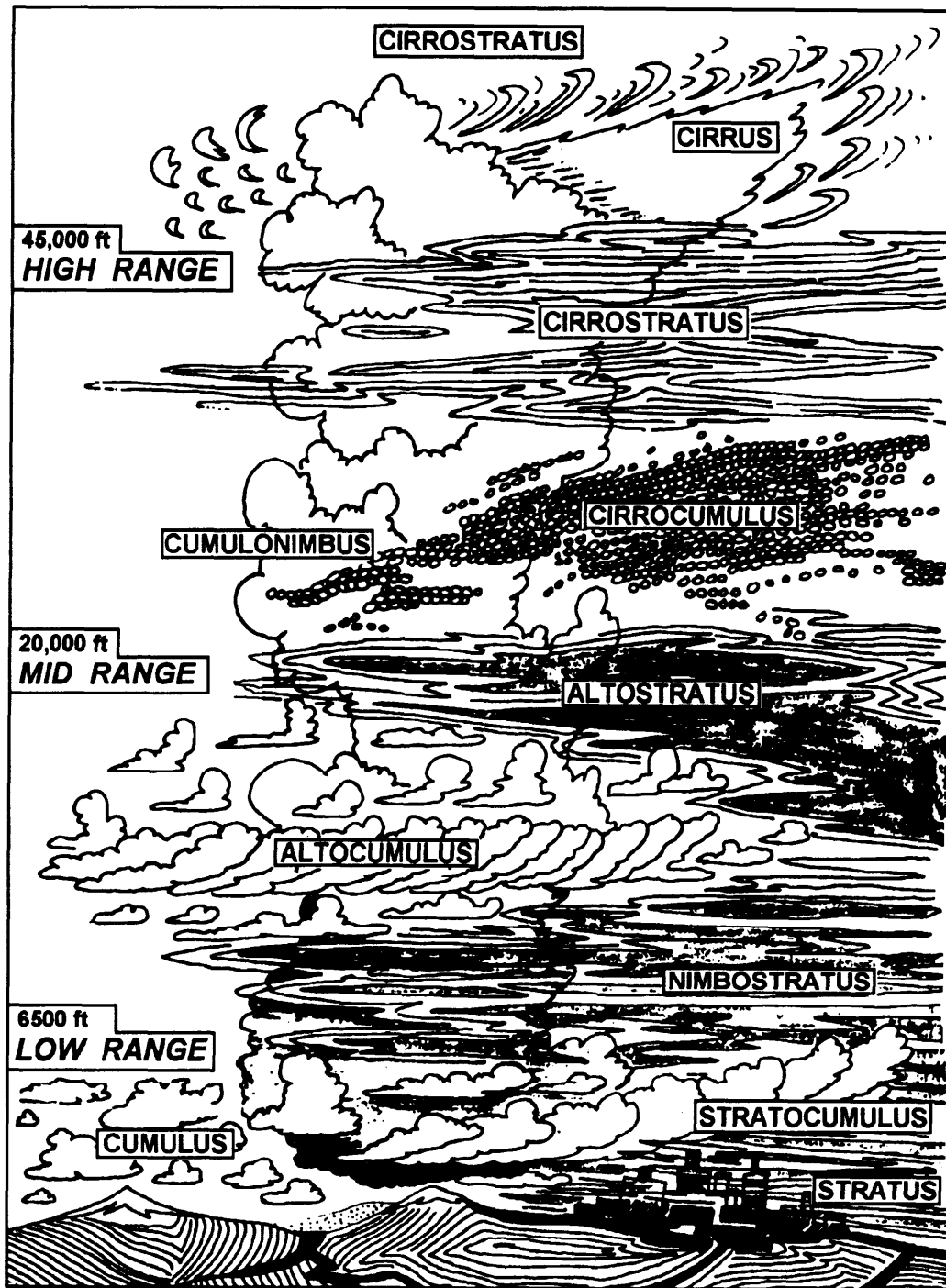

Figure 10-2. Cloud genera and associated heights.

# Cloud Characteristics

---

## High-Etage Clouds

**Cirrus (CI)** clouds are detached clouds of delicate and stringy appearance, generally white in color, without shading. They appear in the most varied forms, such as isolated tufts, lines drawn across the sky, branching featherlike plumes, and curved lines ending in tufts.

Cirrus clouds are composed of ice crystals; hence their transparent character depends upon the degree of separation of the crystals. Before sunrise and after sunset, cirrus clouds may still be colored bright yellow or red. Being high-altitude clouds, they light up before lower clouds and fade out much later. Cirrus clouds often indicate the direction in which a storm lies.

**Cirrocumulus (CC)** clouds, commonly called mackerel sky, look like rippled sand or like cirrus clouds containing globular masses of cotton, usually without shadows. Cirrocumulus clouds indicate that a storm probably is approaching.

**Cirrostratus (CS)** clouds are a thin whitish veil that does not blur the outlines of the Sun or Moon but gives rise to halos (colored or whitish rings and arcs around the Sun or Moon; the colored arcs appear reddish on the inside edges). A milky veil of fog (thin stratus) and altostratus are distinguished from a veil of cirrostratus of similar appearance by the halo phenomenon, which the Sun or Moon nearly always produces in a layer of cirrostratus. The appearance of cirrostratus is a good indication of rain.

---

## Mid-Etage Clouds

**Alto cumulus (AC)** clouds are a layer (or patches) composed of flattened globular masses, the smallest elements of the regularly arranged layer being fairly small and thin, with or without shading. The balls or patches are usually arranged in groups, lines, or waves. Sometimes a corona (similar to a halo but with the reddish color on the outside edges) may be seen on the alto cumulus. This cloud form differs from the cirrocumulus by generally having larger masses, by casting shadows, and by having no connection with the cirrus forms.

**Altostratus (AS)** looks like a thick cirrostratus, but without the halo phenomena, the altostratus is a fibrous veil or sheet, gray or bluish in color. Sometimes the Sun or Moon is obscured completely. At other times they can be vaguely seen, as through ground glass. Light rain or heavy rain may fall from a cloud layer that is definitely altostratus.



## Cloud Characteristics, Continued

---

### Low-Etage Clouds

**Nimbostratus (NS)** clouds are a dark gray-colored amorphous (shapeless) and rainy layer of cloud. They are usually nearly uniform and feebly illuminated, seemingly from within. When precipitation occurs, it is in the form of continuous rain or snow, but nimbostratus may occur without rain or snow. Often there is precipitation that does not reach the ground, in which case, the base of the cloud may extend into the low-cloud family.

**Stratocumulus (SC)** clouds are layer or patches of clouds composed of globular masses or rolls. The smallest of the regularly arranged elements are fairly large. They are soft and gray with dark spots.

**Stratus (ST)** clouds are a low, uniform layer of clouds, resembling fog, but not resting on the ground. A veil of stratus gives the sky a hazy appearance. Usually, only drizzle is associated with stratus. When there is no precipitation, the stratus cloud form appears drier than other similar forms, and it shows some contrasts and some lighter transparent parts.

**Cumulus (CU)** clouds are dense clouds with vertical development. Their upper surfaces are dome-shaped and exhibit rounded projections, and their bases are nearly horizontal. Stratocumulus clouds resemble ragged cumulus clouds in which the different parts show constant change. Strong updrafts exist under and within larger cumulus formations. In fact, cumulus clouds, like other forms of vertically developed clouds, are caused by updrafts.

**Cumulonimbus (CB)** clouds are heavy masses of cloud, with towering vertical development, whose cumuliform summits resemble mountains or towers. Their upper parts leave a fibrous texture, and often they spread out in the shape of an anvil.

Cumulonimbus clouds are generally associated with showers of rain or snow, and sometimes produce hail. Thunderstorms are always associated with cumulonimbus. The bases of the cumulonimbus may be anywhere from 1,600 feet to 6,500 feet. Although you would rarely see all types at any one time in nature, quite frequently you may observe two or three layers of clouds of different types at one observation.

## Cloud Characteristics, Continued

---

### Fog

Fog at sea is frequently formed through the process known as *advection* (the transport of an atmospheric property solely by the mass motion of the atmosphere). If warm air that passed over warm water moves to an area where the water is colder, fog is likely to develop in the latter region. The temperature of seawater is fairly uniform within a large area and accounts for fog that often lasts for many days and nights at sea.

The great fog banks of the North Atlantic, as well as those around the Aleutians, demonstrate what can happen when two adjacent bodies of water have markedly different temperatures. In the vicinity of Newfoundland, warm air that has passed over the warm Gulf Stream quickly turns to fog when it strikes the inshore current of very cold water that flows southward along the coastline. Off Alaska, the same situation prevails when the air from over the warm Japanese stream (Kuroshio) comes in contact with the cold southward-flowing waters of the Bering Sea (Oyashio).

Along coastlines special conditions may exist. Onshore winds blow warm, moist air inland from the ocean. The waters adjacent to the coast are sometimes colder than those farther offshore. At night an onshore wind lays down a thick blanket of fog that often extends some distance inland. The fog hangs on until the Sun heats up the land enough to evaporate the droplets or until an offshore wind drives the fog blanket away.

How can you tell when a fog is on the way or in the process of formation? The difference between the temperature shown by the wet bulb and the dry bulb of the psychrometer, called wet-bulb depression, is your fog indicator.

In general, fog forms when the depression is 4° or less. A continuous record of the wet-bulb depression serves as a fairly reliable predictor of fog.

# Atmospheric Pressure

## Weight

The layer of atmosphere that surrounds us exerts a pressure of approximately 15 pounds per square inch at sea level. The weight of the atmosphere varies with the presence of water vapor as well as with temperature and height above sea level. Variations in atmospheric pressure are measured by an instrument called a barometer.

## Aneroid Barometer

The aneroid (dry or no fluid) barometer (ML-448) (fig. 10-3) needs no correction except for altitude. It contains a small metallic cell, called a syphon cell, which encloses a partial vacuum. As atmospheric pressure increases, the syphon cell contracts; as pressure decreases it expands.

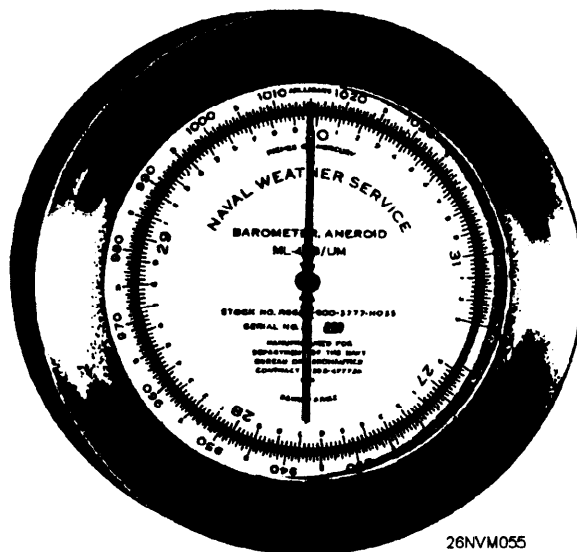

Figure 10-3. Aneroid barometer.

As the syphon cell expands and contracts, it communicates motion to an indicating pointer on a graduated scale.

The aneroid barometer (ML-448) is graduated in inches of mercury and in millibars (mb). Both inches and millibars are measurements of the weight of the atmosphere at a given time or point. The average atmospheric pressure at Earth's surface is 29.92 inches or 1013.2 millibars.

# Atmospheric Pressure, Continued

## Aneroid Barometer, continued

Figure 10-4 shows comparative readings on the inch and millibar scales.

The aneroid barometers normally can be read no closer than 0.01 inch.

Aneroid barometers are the standard pressure-indicating instrument aboard ship and the type of barometers that Quartermasters will encounter most frequently.

Barometers should be calibrated yearly in accordance with PMS.

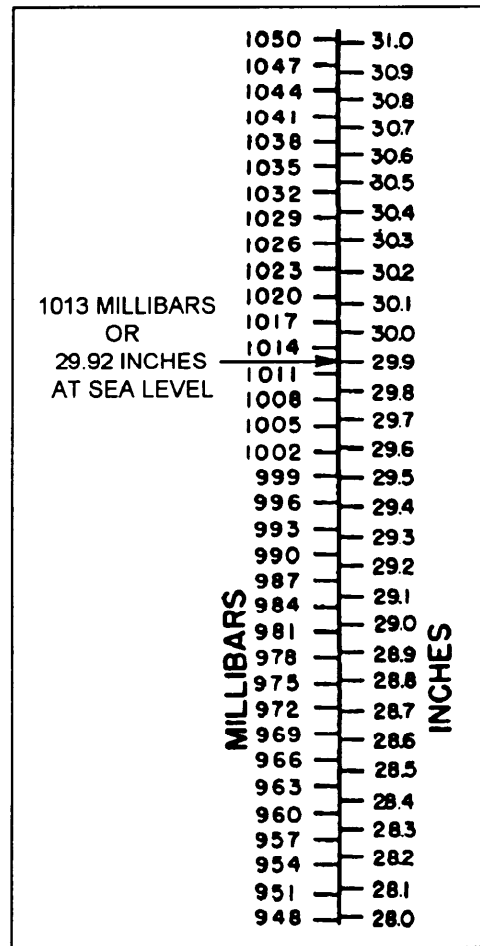

26NVM056

Figure 10-4. Inches and millibars.

## Significance of Pressure

A chart of the atmospheric pressure over a large area of Earth as surface at any given time tells you which way different air masses (an air mass is a large body of air that has common temperature and humidity characteristics) are moving. Some air masses originate in the cold polar regions; some, in the tropics. By the time they reach you, these air masses, called maritime air masses, have moved from vast bodies of water. Others, called continental air masses, have grown up over more or less dry land. Air masses carry along with them the temperature and humidity characteristics of the areas they crossed. Where distinctly different air masses touch, the boundary between them is called a *front* and is marked by cloudiness and precipitation.

# Pressure Areas

**Frontal Weather** The atmosphere can produce weather in other ways, of course, but frontal weather, which is often violent, can be predicted from a chart of pressure systems. Figure 10-5 shows different types of pressure areas on a weather chart.

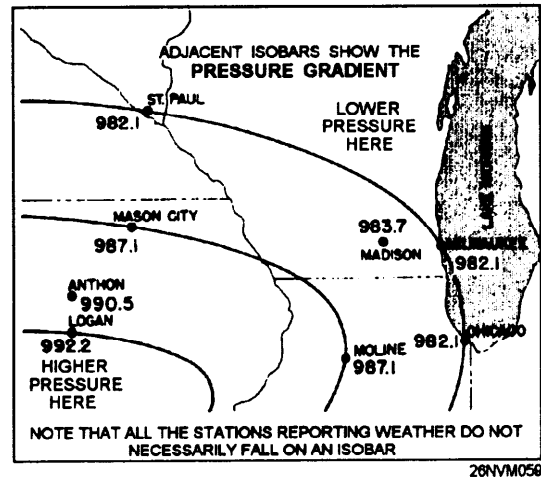
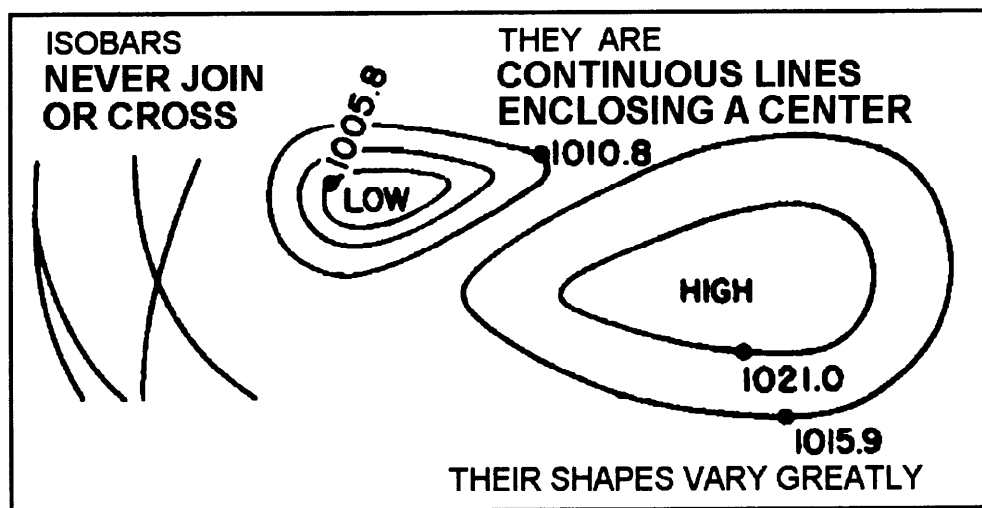

Figure 10-5. Sample weather map.

## Isobars

Atmospheric pressure is reported in millibars. One atmosphere equals 14.696 pounds per square inch, a bar equals slightly more than 0.98 atmosphere, and a millibar equals 1/1000 of a bar.

On weather charts, pressure is usually indicated in millibars (fig. 10-6). The lines shown in the figure are drawn through points of equal pressure and are called isobars.



26NVM060

Figure 10-6. Shapes of isobars.

## Pressure Areas, Continued

### Isobars, continued

Usually, isobars are drawn for equal intervals of pressure (every 4 millibar for example), and frequently, isobars do not pass through reporting stations. Isobars never join or cross. Some may run off the chart, but others may close, forming irregular ovals that define the areas of highest and lowest pressure (fig. 10-6). Air (wind) flows from high-pressure areas to low-pressure areas. The strength of the wind depends upon two factors: the amount of difference in pressure and the distance of the high-pressure area (high) from the low-pressure area (low). These two factors combined are called pressure gradient. The greater the gradient, the stronger the wind. Thus, isobars can give a rough indication of the amount of wind. The closer an isobar is to another, the greater the amount of wind in that area. In figure 10-7, the isobars represent pressures of 992.2 mb, 987.1 mb, and 982.1 mb.

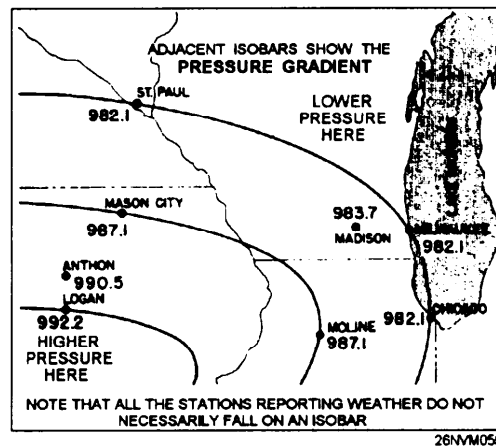

Figure 10-7. Isobaric patterns.

The spacing and shape of isobars are seen in figure 10-6, which also shows how complete isobars are formed. Isobars are always smoothed-out curves, usually making irregular ovals around the high- or low-pressure center.

Refer to figure 10-7 and you can see that only part of each isobar (the upper right portion of the oval) appears in the diagram. In this pressure system, that area of greatest pressure is at the system's center. This high-pressure area is also called a high or an anticyclone. If the pressure is 992.2 mb at Chicago, 987.1 mb at Moline, and 982.1 mb at Logan, the area of lowest pressure is in the vicinity of Logan. This area would be a low, or a cyclone.

# Frontal Systems

---

## Warm Fronts

Active warm fronts are generally located in pressure troughs on surface charts. See figure 10-8. The troughs are not as pronounced as those observed with cold fronts; therefore, other meteorological elements are used as follows in locating warm fronts accurately:

1. **Pressure tendencies.** Pressure usually falls for an appreciable length of time before the front passes. Normally it is steady after passage. The tendencies in advance of the front are therefore a steady or unsteady fall. A warm frontal passage is usually indicated by a tendency.
2. **Wind.** The wind in advance of a warm front in the Northern Hemisphere is usually from the southeast, shifting to southwest after passage. The wind speed normally increases as the front approaches. The wind shift accompanying a warm front is seldom as abrupt as with a cold front.
3. **Cloud forms.** Warm fronts are nearly always well defined by tropical stratified clouds. They are generally cirrus, cirrostratus, altostratus, nimbostratus, and stratus with the cirrus appearing as much as 1,000 miles before the actual surface passage. The cloud types that form after passage of the warm front are typical of the warm air mass.
4. **Precipitation.** The precipitation area of warm fronts extends about 300 miles in advance of the surface front. Precipitation occurs mainly in the form of continuous or intermittent rain, snow, or drizzle. However, when the warm air is connectively unstable, showers and thunderstorms may occur in addition to the steady precipitation.
5. **Temperature and dew-point chances.** Abrupt temperature changes, like those characteristic of cold fronts, do not accompany the warm frontal passage. Instead, the *temperature* change is gradual. It starts increasing *slowly* with the approach of the front and increases slightly more rapidly with the passage. The dew point is normally observed to rise as the front approaches, and a further increase follows the frontal passage when the air in the warm sector is of maritime origin.
6. **Visibility and ceiling.** The visibility and ceiling are normally good until the precipitation begins. Then they decrease rapidly. Dense fog frequently occurs in advance of a warm front. These conditions improve after the front passes.

# Frontal Systems, Continued

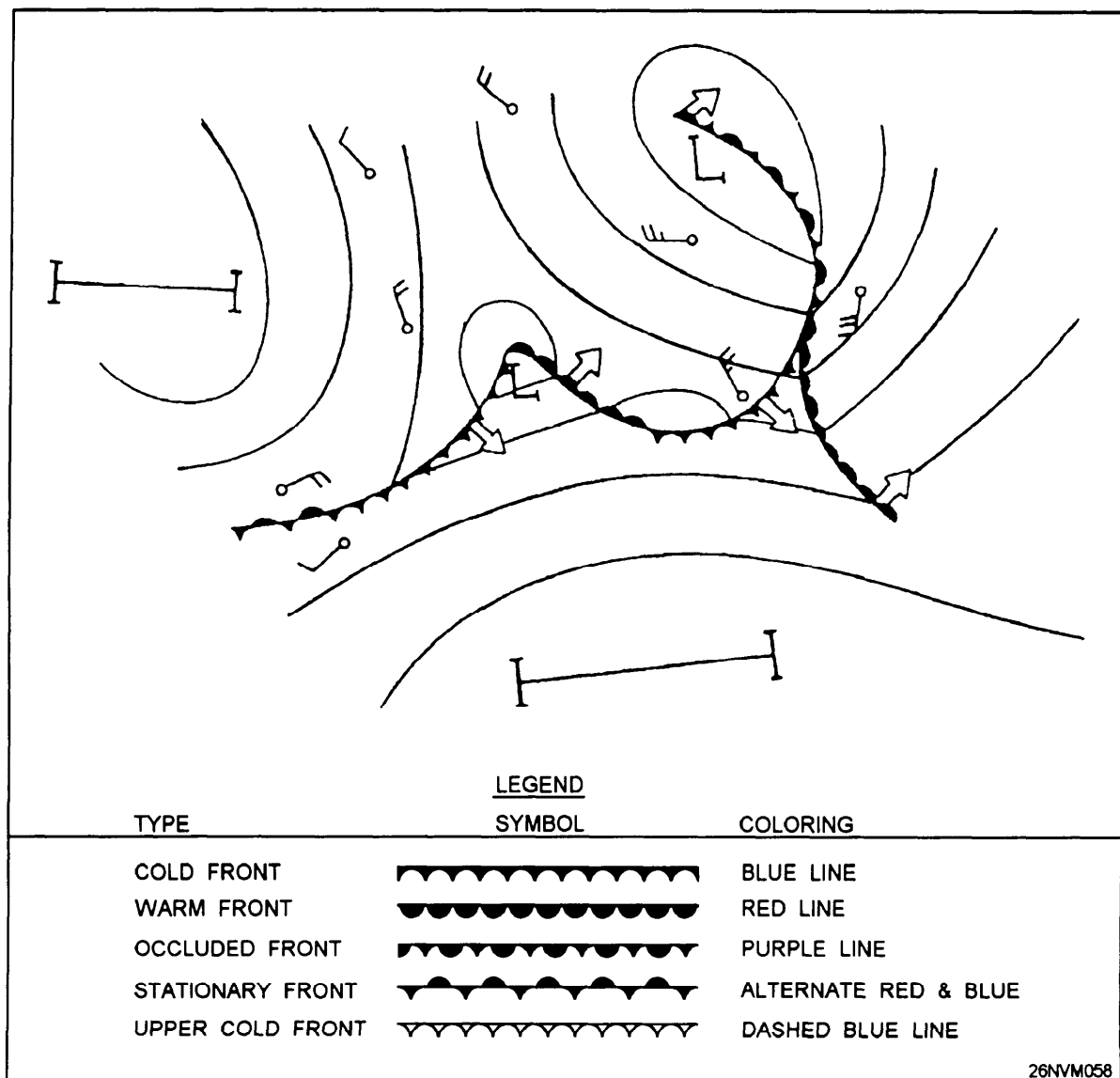

Figure 10-8. Designation of fronts on weather maps.



# Frontal Systems, Continued

---

## Cold Fronts

Cold fronts are normally located in well-deemed pressure troughs whenever there is a marked temperature contrast between two air masses. In most cases, a careful analysis of the isobars indicates the correct position of the pressure trough that contains the front. This method of isobaric analysis is frequently the only possible means of locating fronts over ocean areas or regions of scanty surface reports. Other indications of cold fronts can be classified as prefrontal, frontal, or postfrontal as follows:

1. **Pressure tendencies.** In advance of cold fronts, the tendency characteristic is usually indicated by a steady or unsteady fall. The isobars of falling pressure in advance of the front usually form an elongated pattern approximately parallel to the front. After passage of the front, the tendency generally shows a steady rise.
2. **Wind.** With the approach of the front, the wind is normally from the south or southwest in the Northern Hemisphere, veering to parallel the front. At the passage, the wind generally shifts abruptly to the northwest. Very gusty winds frequently occur at the frontal passage and usually after passage.
3. **Cloud forms.** In advance of cold fronts, the cloud types are typical of the warm air. Towering cumulus, cumulonimbus, stratocumulus, and nimbostratus are associated with the passage. After passage, these cloud forms may prevail for several hundred miles with the slow-moving cold front. Very rapid clearing conditions are associated with the fast-moving cold front after passage. Well back in the cold air in both types of cold fronts, the only clouds normally found are fair-weather cumulus.
4. **Precipitation.** Showers and sometimes thunderstorms occur as a cold front passes. Continuous precipitation is observed for some hours after passage of a slow-moving cold front. Showers and thunderstorm activity of short duration will occur with the passage of a fast-moving cold front, followed by very rapid clearing conditions.

## Frontal Systems, Continued

---

### Cold Fronts, continued

5. **Temperatures.** Temperature is relatively high before passage. After passage, the temperature decreases very rapidly with slow-moving fronts. Such a rapid temperature change does not accompany the passage of fast-moving cold fronts; the real temperature change is usually seen some distance (as far as 50 to 100 miles) behind the front.

6. **Dew point.** The dew-point temperature generally helps to locate fronts. This is especially true in mountainous regions. A drop in the dew point is observed with the passage of either type of cold front.

7. **Visibility and ceiling.** With the approach and passage of a slow-moving cold front, the visibility and ceilings decrease and remain low after the passage until well within the cold air. Fast-moving cold fronts are preceded by regions of poor visibility and low ceilings due to shower activity. After passage of fast-moving cold fronts, the ceiling rapidly becomes unlimited and the visibility unrestricted.

---

**Occluded Fronts** Because the occlusion is a combination of a cold front and a warm front, the resulting weather is a combination of conditions that exists with both. Ahead of a cold-type occlusion, as the warm air is lifted, all clouds associated with a warm front are found producing typical prefrontal precipitation extensively for a distance of 250 to 300 miles. Typical cold front weather is found throughout the narrow belt in the vicinity of the surface front. However, the thunderstorms are less intense than those of a typical cold front. This occurs because the source of warm air has been cut off from the surface, and the energy received comes only from the warm air trapped aloft. Instability showers often follow the cold front when the cold air is unstable. The most violent weather occurs on the upper front for a distance of 50 to 100 miles north of the northern tip of the warm sector. After the occlusion has passed, the weather usually clears rapidly. The weather associated with the warm occlusion is very similar to that of the cold occlusion. With the warm occlusion, the high-level thunderstorms associated with the upper cold front develop quite some distance ahead of the surface front (up to 200 miles), and the weather band, in general, is wider (up to 400 miles). The air behind the cold front, flowing up the warm frontal surface, causes cumuliform-type clouds to form. In this area, precipitation and severe icing may be found. The most violent weather occurs on the upper front, 50 to 100 miles north of the northern tip of the warm sector.

# Wind

## Determining Wind Speed

---

For reasons previously discussed in this chapter and for reporting purposes, Quartermasters must be able to compute the direction and velocity of the true wind. The following discussion contains instructions for observing the wind speed and direction and computing true wind data (speed, direction, gusts, and shifts).

The movement of the ship affects the wind speed observed by both the ship's anemometers and hand-held anemometer. Relative wind is measured from the direction and speed from which the wind appears to be blowing. Relative wind seldom coincides with true wind because the direction and speed of the relative wind are affected by the ship's movement. For example, if your ship is heading north at 10 knots and true wind is blowing from the south at 10 knots, there appears to be no wind at all. In another example, your ship is heading north and the wind appears to be blowing in on the port bow, but the true wind is actually coming from the port quarter. In our discussion of the different types of wind, refer to the following explanations:

1. True wind (TW) is the velocity and direction from which the true wind is blowing.
2. Relative wind (RW) is the velocity and relative direction from which the wind is blowing in relation to ship's heading (SH).
3. Apparent wind (AW) is the velocity and true direction from which the relative wind is blowing. For example, if your ship is heading 090° and the relative wind is blowing in on your starboard bow (045°) at 15 knots, the apparent wind is from 135°T at 15 knots. The formula for apparent wind is:  $AW = RW + SH$ .

Wind speed (including gusts and squalls) is observed, computed, and reported in nautical miles per hour (knots) to the nearest whole knot. Since the true wind must be computed, the chance of committing an error is increased. The wind data reported is used as criteria for wind, storm, and high seas warnings. Care must be taken whenever computing true wind. Wind data can be observed using the following methods listed in order of preference:

1. Installed anemometer
2. Hand-held anemometer
3. Visual estimation

## Wind, Continued

### Installed Anemometers

An installed anemometer (fig. 10-9) is an instrument fixed somewhere aloft, usually at the masthead. The wind blows on a propeller attached to one end of a wind vane that pivots. The whirling propeller revolves a spindle, communicating with a synchro repeater on a pilothouse or chart house bulkhead. Figure 10-10 shows one type of synchro repeater.

The upper dial of the repeater is graduated in 10-degree intervals and shows the relative direction from which the wind is blowing. In this illustration the direction is about  $287^\circ$ . The lower dial indicates the relative wind speed (true wind speed when the ship is stationary). The wind speed dial in the illustration shows about 87 knots. This reading means that the force exerted by 87 knots of wind is whirling the anemometer propeller.

When using an installed anemometer, always compare the readings observed with the wind conditions as they appear outside. If two anemometers are installed, make sure that the windward anemometer is used.

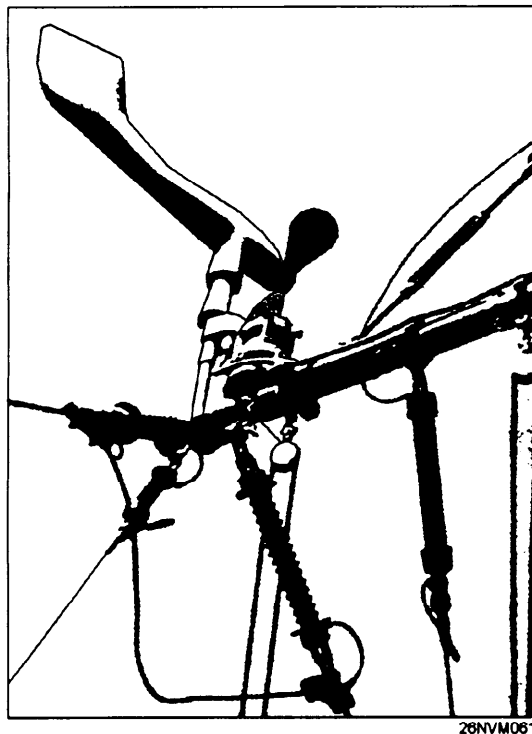

Figure 10-9. Installed anemometer.

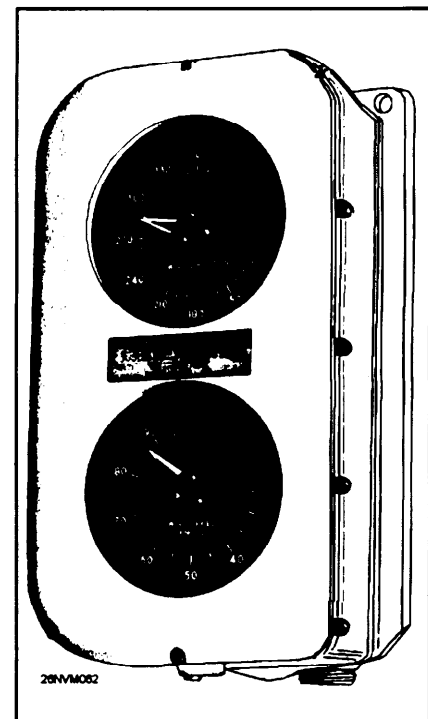

Figure 10-10. Synchro repeater.

## Wind, Continued

### Using Hand Held Anemometers

If anemometers are not installed or not working properly, or for some reason the readings are in doubt, the hand-held anemometer should be used. The Wind Measuring Set AN/PMQ-3 (fig. 10-11) is a hand-held anemometer. It is a combination wind direction and speed indicator. It indicates direction to 360° and speed from 0 to 60 knots. The speed indicator has two scales, graduated from 0 to 15 knots and 0 to 60 knots. To use the hand-held anemometer, you choose an observation point on the windward side of the ship, as far upwind as possible. For example, if the wind is from the stem, go aft; if it is from the bow, go forward. If possible, stand facing parallel to the ship's centerline and into the wind.

When you use the hand-held anemometer, follow the instructions given in the table below.

Step	Action
1.	Grasp the instrument by the handle and hold it in an approximately vertical position at arm's length with the sight at eye level.
2.	Aim the instrument at an imaginary point on the horizon. This is done by aligning the center of the slot in the front of the sight with the center of the strip between the two slots on the rear sight. Aim it as you would a gun.
3.	Press and hold the vane locking trigger. Note the reading on the 0 to 60 (upper) scale on the wind speed indicator. If the wind speed reading is less than 15 knots, press the range selecting trigger on the side of the housing, and observe the reading on the 0 to 15 scale. Care must be taken not to take the first reading on the 0 to 15 scale because a wind speed in excess of 15 knots may damage the anemometer.
4.	Note the motion of the wind vane as it moves between the extremes, and release the vane locking trigger when the vane is in the position of the predominant (average) wind direction. Carefully lower and tilt the anemometer and note the wind direction reading on the direction dial. If the wind is being observed facing aft, the direction must be converted in relation to the bow. Add 180° for directions from 0° through 90°. Subtract 180° for directions from 270° through 360°.
5.	Maintenance of the AN/PMQ-3 should be in accordance with PMS instructions.

Hand held  
Anemometer

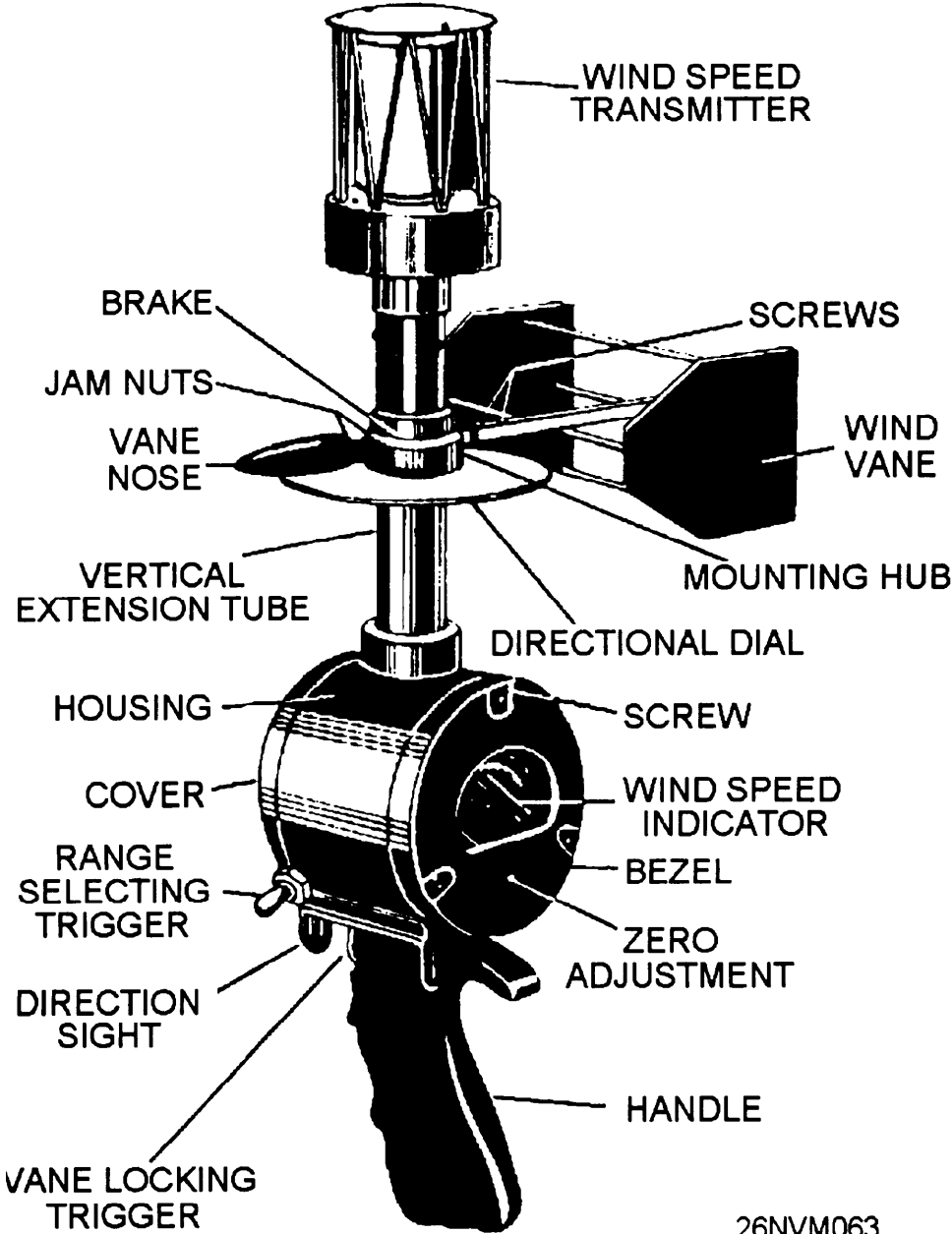

26NVM063

Figure 10-11. Hand-held anemometer.

## Wind, Continued

---

### Visual Estimation of Wind Speed

True wind direction may be observed by noting the direction from which ripples, small waves, and sea spray are coming. The direction is most easily found by sighting along the wave crests and turning 90° to face the advancing waves. The observer is then facing the true wind direction. You may estimate the true wind speed by noting the sea condition and referring to table 10-1, which is based upon the following assumptions and should be considered in arriving at an estimated true wind speed:

1. The wind has been blowing at a relatively constant speed and direction for the time indicated by table 10-1.
2. The fetch area (an area where waves are being generated by the wind) is unlimited.

Some factors that cause the speed estimation of the wind to be too low are as follows:

1. Winds have increased rapidly.
2. Offshore winds within the sight of land.
3. Moderate or heavy precipitation smoothing the sea surface.
4. Swell waves from varying directions.

Some factors that will cause the speed estimation of the wind to be too high are as follows:

1. Waves running into shallow water.
2. A decreasing wind speed. The relative wind speed and direction can be estimated by observing the ship's flag, smoke, and rigging on the windward side of the ship. Table 10-1 should be used when you are using this method. Notice that this method gives you the relative wind and should be used only when the surface of the sea cannot be observed.

## Wind, Continued

Knots	Beaufort Number	Wave Ht. in feet	Description	Sea Conditions
0	0	0	Calm	Sea smooth and mirrorlike.
1-3	1	1/4	Light air	Scalelike ripples without foam crests.
4-6	2	1/2	Light breeze	Small, short wavelets; crests have a glassy appearance and do not break.
7-10	3	1	Gentle breeze	Large wavelets; some crests begin to break. Occasional white foam crests.
11-16	4	3	Moderate breeze	Small waves, becoming longer; fairly frequent white foam crests.
17-21	5	6	Fresh breeze	Moderate waves, taking a more pronounced long form; many white foam crests; there may be some spray.
22-27	6	12	Strong breeze	Large waves begin to form; white foam crests are more extensive everywhere; there may be some spray.
28-33	7	*15	Near gale	Sea heaps up, and white foam from breaking waves begins to be blown in streaks along the direction of the wind.
34-40	8	**20	Gale	Moderately high waves of greater length, edges of crests break, foam is blown in well-marked streaks along the direction of the wind.
41-47	9	***30	Strong gale	High waves; dense streaks of foam along the direction of the wind; crests of waves begin to roll over; spray may reduce visibility.
48-55	10	***40	Storm	Very high waves with long overhanging crests. Foam in great patches is blown in dense white streaks along the direction of the wind. Visibility is reduced.
56-63	11	***50	Violent storm	Exceptionally high waves. The sea is completely covered with long, white patches of foam lying along the direction of the wind. Visibility reduced.
64 and over	12	***60+	Hurricane	The air is filled with foam and spray. Sea completely white with driving spray; visibility very much reduced.
<p>* Duration time of 16 hours, not fully arisen</p> <p>** Duration time of 20 hours, not fully arisen</p> <p>*** Duration time of 24 hours, not fully arisen</p> <p>Fetch is assumed to be unlimited.</p>				

26NVM064

Table 10-1. Estimating True Wind By Sea Conditions



## Wind, Continued

---

### Calculating True Wind Using the True Wind Computer

Once the relative wind direction and speed have been observed and the ship's course and speed recorded, the true wind can be computed. The True Wind Computer (CP 264/U) is the quickest and easiest method. Detailed instructions on the use of the True Wind Computer can be found in Chapter 10 of the *Manual for Ship's Surface Weather Observations*, NAVOCEANCOMINST 3144.1C.

---

### Calculating True Wind Using the Maneuvering Board

The use of the maneuvering board (MB) is by far the most accurate method of determining true wind. The MB uses exact vectors to establish apparent wind and own ship's speed. The use of vectors makes this method more precise.

Information on calculating true wind can be found in Pub 217 *Maneuvering Board Manual*, therefore it will not be duplicated here. Pub 217 also contains solutions for finding desired wind, closest point of approach, and several other vector solutions that are invaluable to the Quartermaster assisting the officer of the deck.

---

### Computation Check

No matter which method of computation is used to derive the true wind direction and speed, the observer should check the results by applying the following rules:

**Rule 1:** The true wind direction is always on the same side of the ship as the apparent wind direction, but farther from the bow than the apparent wind direction.

**Rule 2:** When the apparent wind direction is abaft the beam, the true wind speed is greater than the apparent wind speed.

**Rule 3:** When the apparent wind direction is forward of the beam, the true wind speed is less than the apparent wind speed.

# Temperature, Dew Point, and Relative Humidity

---

## Measuring Temperature

You probably don't need to be told that a thermometer is an instrument for measuring temperature. Generally speaking, it is a glass tube of small bore in which either alcohol or mercury expands and contracts with the rise and fall of the temperature of the surrounding medium. Most Navy thermometers are mercury-filled and practically all of them use the Fahrenheit (F) scale, where the freezing point of water is 32° and its boiling point is 212°. Temperature in meteorology, however, is sometimes expressed according to the Celsius (C) (formerly Centigrade) scale, where the freezing point of water is 0° and its boiling point is 100°.

You may be required to convert a Fahrenheit reading to Celsius, or vice versa. Knowing that 32°F = 0°C, to change a Fahrenheit reading to Celsius, you first subtract 32° and then multiply the remainder by 5/9.

**Example:** Say you want to change 41°F to Celsius. Subtracting 32° from 41° gives 9°. Multiply 9° by 5/9, and you get 45/9, or 5°C.

To change from Celsius to Fahrenheit, simply reverse the procedure. First multiply the Celsius temperature by 9/5, then add 32°. In the previous example, to change 5°C back to Fahrenheit, first multiply it by 9/5, which gives you 45/5, or 9°. Adding 32° gives you 41°F.

You may also use the following formulas:

$F = 1.8 \times C + 32$  (Multiply Celsius temp by 1.8, then add 32 to find Fahrenheit)

$C = (F - 32) \div 1.8$  (Fahrenheit minus 32, then divide by 1.8 to find Celsius)

A thermometer must be read properly to obtain an accurate result. First, if you must handle it, be sure that you do not touch the lower part of the glass containing the alcohol or mercury, because the heat from your body can affect the height of the mercury or alcohol column. Make certain that the top of the column is level with your eyes; otherwise you will be reading a higher or lower graduation than the one actually indicated. The top of the column is in the shape of a curve called a meniscus. It is the bottom of this curve that indicates the reading for an alcohol thermometer; the top, for a Mercury thermometer.

## Temperature, Dew Point, and Relative Humidity, Continued

---

### Measuring Dew Point and Relative Humidity

As already mentioned, the amount of water vapor the atmosphere can hold varies with the temperature. When the atmosphere contains all the water it can hold for a given temperature, the air is at the saturation point or humidity is 100%. If it contains 50% of what it could hold at that particular temperature, relative humidity is 50%. Relative humidity and dew point are determined through the use of a psychrometer.

---

### Using the Sling Psychrometer

A psychrometer is simply two ordinary thermometers mounted together on a single strip of material. The bulb of one thermometer is covered by a water-soaked wick from which the water evaporates rapidly or slowly, depending on the amount of water vapor in the surrounding atmosphere.

Evaporation of water around the wet thermometer cools it. The amount of cooling depends on the rate of evaporation. The reading on the wet bulb is lower than the reading on the dry bulb except when the humidity is 100%, at which time both readings coincide. The difference between the wet-bulb and dry-bulb readings, when applied to tables developed for that purpose, results in relative humidity and dew point temperature.

The dew point is the temperature to which air must be cooled at constant pressure and constant water vapor content to reach saturation (100% relative humidity). When air is cooled to its dew point temperature, small water droplets condense on objects; that is, dew forms.

A sling psychrometer (fig. 10-12) is sometimes used to speed up the process of getting accurate wet-bulb and dry-bulb readings. The sling psychrometer can be whirled around to rapidly bring the wet bulb into contact with a great volume of air. This contact with air accelerates the evaporation rate. The person using the sling psychrometer should face the wind and should shield the instrument as much as possible from the direct rays of the Sun. The whirling should be repeated until no further change can be detected in the wet-bulb reading.

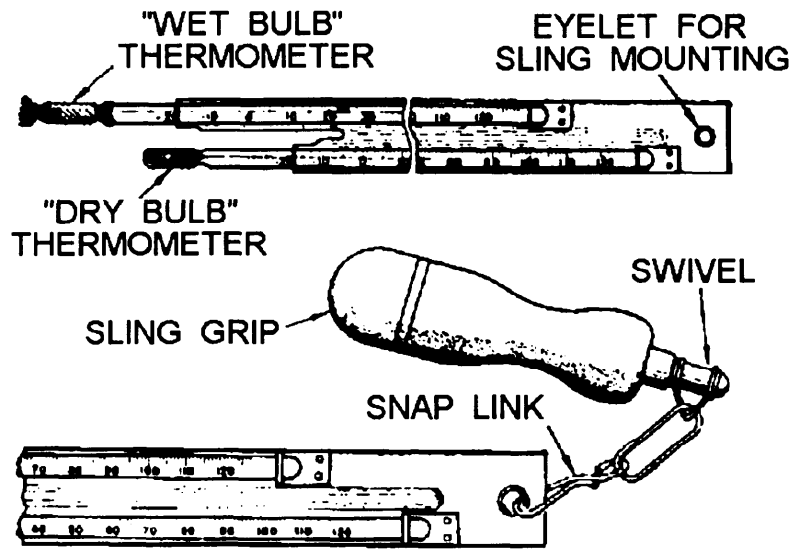

26NVM065

Figure 10-12. Sling psychrometer.

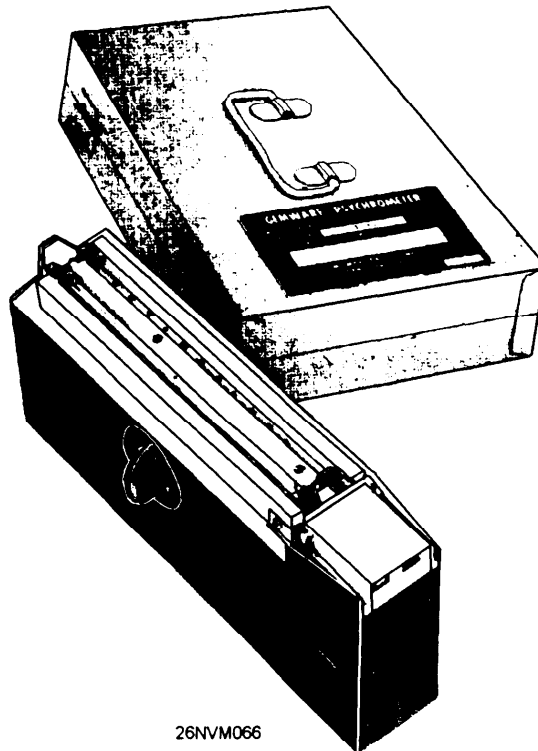

26NVM066

Figure 10-13. Electric psychrometer.

# Temperature, Dew Point, and Relative Humidity, Continued

## Electric Psychrometer

The Electric Psychrometer ML-450/UM (fig. 10-13) is a hand-held portable instrument that serves the same purpose as the sling psychrometer. As a Quartermaster this will probably be the only type of psychrometer that you use, since most ships do not carry the sling psychrometer. Three D-size batteries furnish power to a self-contained ventilation fan that aspirates the thermometer. The instrument also contains a lamp for nighttime readings. When using the electric psychrometer, select a shady area with no obstructions within 3 to 4 feet and face into the wind. Hold the instrument at waist height with the air intake pointing into the wind. Obtain the dry-bulb temperature first. When the ambient (circulating) air temperature is 50°F, or above, it is not necessary to energize the ventilation fan. The electric psychrometer should be exposed to the ambient air for at least 5 minutes before you read it. When no further decrease of the wet-bulb temperature is apparent, read the wet-bulb.

## Finding the Dew Point

Use the psychrometer table 10-2 to compute the dew point. The *Manual for Ship's Surface Weather Observations* (NAVOCEANCOMINST 3144.1C) contains complete tables. Take a dry-bulb temperature of 70°F and a wet-bulb temperature of 60.5°F. The difference between the two readings, 9.5°F, is called the wet-bulb depression.

**Example:** To compute the dew point, you enter the wet-bulb reading (60.5°F). Go to the proper DEPRESSION column (9.5°F). Read the dew point temperature (54°F) directly from the intersection of the temperature row and the DEPRESSION column.

Table 10-2. Psychrometer Table

(Tabular values are dew points with respect to water)

Wet-bulb temperature (°F)	Depression of the wet-bulb thermometer (dry-bulb minus wet-bulb)																				
	0.5	1.0	1.5	2.0	2.5	3.0	3.5	4.0	4.5	5.0	5.5	6.0	6.5	7.0	7.5	8.0	8.5	9.0	9.5	10.0	10.5
60.0	60	59	59	59	58	58	58	57	57	57	56	56	56	55	55	55	54	54	54	53	53
60.5	60	60	60	59	59	59	58	58	57	57	57	56	56	56	55	55	55	55	54	54	54
61.0	61	60	60	60	60	59	59	59	58	58	58	57	57	57	56	56	56	55	55	55	54
61.5	61	61	61	60	60	60	59	59	59	58	58	58	58	57	57	56	56	55	55	55	55
62.0	62	61	61	61	61	60	60	60	59	59	59	58	58	58	57	57	57	56	56	56	55
62.5	62	62	62	61	61	61	60	60	60	60	59	59	59	58	58	58	57	57	57	56	56
63.0	63	62	62	62	62	61	61	61	60	60	60	60	59	59	59	58	58	58	57	57	57
63.5	63	63	63	62	62	62	62	61	61	61	60	60	60	59	59	59	59	58	58	58	57
64.0	64	63	63	63	63	62	62	62	62	61	61	61	60	60	60	59	59	59	58	58	58
64.5	64	64	64	63	63	63	63	62	62	62	61	61	61	60	60	60	59	59	59	58	58

26NVM067

# Weather Observation and Reporting

---

## Observation

Timely and accurate environmental observations are basic to the development of meteorological and oceanographic forecasts in support of fleet operations. Since the U.S. Navy may be committed to operations anywhere in the world, global observations of meteorological and oceanographic conditions are required. In remote areas (especially over oceans), environmental data are extremely sparse.

Accordingly, observations from Navy ships are particularly vital. In short, all ships at sea are required to take regular observations, but where ships are steaming in company or in close proximity (within 10 miles), the OTC may designate one of the ships to report observations for the group. Ships in port are required to continue regular weather observing and reporting by electronic means unless there is a nearby U.S. manned weather reporting activity.

In-port weather observing and reporting guard ship arrangements may be used for groups of ships at the discretion of the senior officer present. In such instances, the weather logs of exempted ships should bear a notation of the guard ship(s) and effective dates/times. Additional and special weather observations and reporting schedules that may be required in support of fleet operations are issued in pertinent operation plans and orders. Requirements for increased frequency of weather reporting by ships at sea in specific areas, particularly in areas where tropical disturbances are suspected or known to exist, should be issued as necessary by the area or force commander.

---

## Recording the Weather

All ships taking surface weather observations must use the form CNOOC 3140/8. This form contains two code forms and is divided into two sections, parts I and II.

**Part I:** Part I is the Ship Aviation Observation Code. This code is in the aviation observation code format with additional ship and sea data columns.

**Part II:** Part II is the Synoptic Code Message Format. It is determined from analyzing data from part I. The data is transmitted via radio message to the appropriate weather center.

## Weather Observation and Reporting, Continued

---

### **Rules for Using CNOC 3140/8**

CNOC 3140/8 is an official document and is the only record of weather encountered by the ship. All entries must be neat and legible. Care should be taken to avoid writeovers and partial erasures that confuse the legibility of the data entered. It is recommended that a folder or board be devised to protect the form between observations. An original and one duplicate of this form is required for each day's observations. The duplicate may be a rewritten copy, a carbon copy, or a suitable photocopy of the original form. The duplicate should be retained for a minimum of 1 year as part of the ship's record. All entries should be made with a black lead pencil (No. 2 or 2H) or an erasable ball-point pen, if available.

Corrections may be made by erasing the erroneous data only if the data has not been disseminated by any means (phone, radio, and message transmittal). Erase the erroneous data from all copies of the form and enter the correct data. When a carbon copy of the form is made, care must be taken to prevent carbon smudges on the duplicate copy.

If an error is discovered in encoded data after it has been transmitted, the erroneous data may not be erased. Using a red pencil, correct the error by drawing a line through the error and entering the correct data above it. Retransmit the observation with the corrections.

You must refer to *the Manual for Ship's Surface Weather Observations* (NAVOCEANCOMINST 3 144.1 Series) for step-by-step instructions on how to complete each column. A new form must be started at 0000 GMT each day. The 2355-59 observation will be the first observation of the new day. If the lines are filled in part I before the day is over, continue the observations on a new form. Continue to make entries in column 90 and part II on the first form.

In the following tables you will find an explanation for each column of both parts I and II of CNOC 3140/8. The example figure provided gives sample data from actual observations on part I and encoding for part II. Use the table and figure together to learn about the information contained within parts I and II.





# Weather Observation and Reporting,

		DATE 1 AUGUST 1985				QUARTERMASTER AEROGRAPHER'S MATE <input checked="" type="checkbox"/>				
REMARKS AND SUPPLEMENTARY CODED DATA DESIRED ORDER OF ENTRY: SFC based on obsc phenomena, remarks elaborating on preceding coded data		OBS INT (15)	STATION PRESSURE (Inches) (17)	SKY COVER TOTAL (21)	POSITION QLU II (A)	COURSE (B)	SPD (C)	SEA WATER (1/10C°) (D)	SEA WAVES PERIOD HEIGHT (E)	SWELL WAVES DIRECTION PERIOD HEIGHT (F)
(13)										
		RLW	29.645	5	74525	230	18	10.0	0201	340601
		RLW	29.600	7	74525	230	18	10.1	0201	340601
		RLW	29.580	10	74525	230	18	10.3	0303	320602
		RLW	29.525	10	74525	230	12	10.7	0704	300802
		RLW	29.505	10	74525	230	10	10.9	0907	301003
		RLW	29.480	10	74525	230	10	11.2	1012	301205

**SSAGE FORMAT**

SECTION 2																			
7	wwW1W2	8	N1C1C2MCH	8hh	//	222	Dsvs	0	S1TwTwTw	2PwPwHwHw	3d d	d d	4 P P H H	5 P P H H	6	IsEsEsRs	ICE	C18pDZ1	
											w1 w1	w2w2	w1w1w1w1	w2w2w2w2					
7		8			//	222		0		2	3		4		6		ICE		
7		8			//	222		0		2	3		4		6		ICE		
7	6364	8	87//		//	222	54	0	0112	2	1012	3	30	4	1205	6		ICE	
7		8			//	222		0		2	3		4		6		ICE		
7		8			//	222		0		2	3		4		6		ICE		
7		8			//	222		0		2	3		4		6		ICE		
7		8			//	222		0		2	3		4		6		ICE		
7		8			//	222		0		2	3		4		6		ICE		

26NVM069

## Weather Observation and Reporting

Column Number	Column Name	Explanation
1	Type	Either SA for hourly observation, or L for local observation (OBS). OBS are required for aircraft mishaps, collisions, man overboard.
2	Time	The time of the OBS always in GMT, must be recorded within 5 minutes, from 55 to 59 only!
3	Sky and Ceiling	The base of each layer of clouds and the type of sky cover associated with that layer. Always drop the last two zeros for the height. 15 BKN = 1500 feet and broken sky coverage at that layer.
4	Prevailing Visibility	This is the prevailing visibility reported to the nearest nautical mile.
5	Weather and Obstructions	Report items such as funnel clouds, hail, sleet, and fog.
6	Sea Level Pressure	Sea level pressure in millibars, entered in ten, units, and tenths. Enter 132 for 1013.2.
7	Temperature	Enter the dry-bulb temperature from the psychrometer.
8	Dew Point Temperature	The nearest dew point temperature to the nearest whole degree Fahrenheit.
9	Wind Direction	The direction from which the TRUE wind is blowing.
10	Wind Speed	Average wind speed at the time of OBS.
11	Wind Character	Gusting or squalling if appropriate.
12	Altimeter Setting	Station pressure reduced to sea level.
13	Remarks	Operationally significant information.
15	Observers Initials	Self explanatory.
17	Station Pressure	Pressure in inches.
21	Total Sky Cover	Estimated total sky coverage by clouds or other obstruction reported in tenths.

## Weather Observation and Reporting, Continued

---

Column Number	Column Name	Explanation
(A)	Position	Abbreviated ship's position.
(B)	Course	General direction of the ship's course.
(C)	Speed	Ship's speed.
(D)	Seawater Temperature	Seawater temperature reported to the nearest 0.1 Fahrenheit.
(E)	Sea Waves, Period, and Height	The duration in seconds from the crest of one wave to the next and the average wave height. Sea waves are caused by local wind conditions.
(F)	Swell Waves, Direction, Period, and Height	The direction, duration in seconds from the crest of one wave to the next, and the average wave height.

---

### CNOC 3140/8 Part II

Part II is designed to allow transmission via radio message of **encoded** weather information. The step-by-step instructions are printed in the *Manual for Surface Ship's Weather Observations* and will not be reproduced here. This manual should be consulted **each time an OBS is made**.

---

### Additional Reporting Requirements

Ship's are required to submit encoded weather every 6 hours of GMT. For example a message should be sent at 0000, 0600, 1200, and so on.

If winds are greater than 33 knots, then messages must be sent with an immediate precedence every 3 hours.

---

### Additional Information

As you may have guessed, weather, like navigation, is a complex subject on which volumes have been written. The objectives of this chapter are to prepare you to report the weather; however, senior QMs should thoroughly acquaint themselves with all aspects of weather. The AG series of TRAMANs is an excellent place to begin. Also Pub No. 9, *Bowditch*, has comprehensive information about weather and the mariner.



# Chapter 11

## The Ship's Bridge

---

### Introduction

In this chapter you will learn about the ship's bridge, where the Quartermaster spends most of his or her time. We will put together much of what you have learned previously in this book plus new topics.

The ship's bridge is where all orders concerning the actions of the ship are issued. While under way the officer of the deck (OOD) directs every action. As Quartermaster of the watch (QMOW), you will be an assistant to the OOD. You are responsible for knowing not only your duties but also those of all bridge watchstanders and the operation of all bridge equipment. In the last section of this chapter, the duties of the QMOW will be described for each watch stood throughout the a day at sea.

---

### Objectives

This material in this chapter will enable the student to:

- Identify steering control consoles components.
- Steer the ship from the bridge.
- Steer the ship from after steering.
- Steer the ship during special evolutions.
- Describe the effects of wind and current on the ship.
- Rig and verify combinations of navigational lights.
- Describe the components of tactical messages.
- Identify flags and pennants.
- Encode and decode tactical signals.
- Operate ship's radars.
- Prepare commanding officer's night orders.
- Maintain Ship's Deck Log.
- Determine and plot the ship's position .
- Maintain logbooks.
- Maintain the DR track.
- Maintain a plot in support of weapons.
- Determine ship's position in relation to PIM.
- Compute estimated time of arrival.
- Determine set and drift and make recommendations to the OOD.
- Time celestial observations.
- Provide input for ship's position reports.
- Render honors and ceremonies.
- Report visual contacts.

## Objectives, Continued

---

### Objectives

- Make recommendations based on Rules of the Road.
  - Read flaghoist display.
  - Set up the bridge for special evolutions.
  - Describe the duties of QMOW while at anchor.
  - Dress and full dress the ship.
  - Hold morning and evening colors.
- 

Topic	Page
Bridge Equipment	11-3
Ship's Characteristics	11-7
Steering the Ship	11-11
Navigational Lights	11-15
External Communications	11-19
Bridge Watch Personnel	11-21
Relieving the QMOW	11-25
Commanding Officer's Night Order Book	11-26
The Ship's Deck Log	11-27
General Duties of the QMOW	11-34

# Bridge Equipment

---

## Introduction

As you might imagine, there are many pieces of equipment on any ship's bridge. Each ship class has installed equipment to enable that ship to do its job. It would be almost impossible to describe each and every piece of equipment that would be found on the bridge of a ship. However, equipment that is normally found on all bridges will be covered. As a QMOW, you are responsible for knowing how to operate all equipment located on the bridge of the ship to which you are assigned. This may seem to be a large tasking; however, as you complete PQS for different watch stations on the bridge, you will gain the required knowledge to operate the bridge equipment for your ship.

---

## Steering Control Consoles (SCC)

The ship's control console contains apparatuses for controlling the movements of a ship. Figures 11-1, 11-2, and 11-3 show three types of ship control consoles in use aboard ships today. As you can see from these figures, the ship control console's physical appearance may differ from ship type to ship type. On ships that have a ship control console like those shown in figures 11-1 and 11-2, the helmsman must also complete PQS for ship control console operator. On the bridge of older ships, like the one shown in figure 11-3, the helm, engine order telegraph, rudder angle indicator, and steering gyro repeaters are all located in the near vicinity of the helmsman, but at different locations on the bridge.

On newer ships, the ship control console houses all the apparatuses for steering the ship and for controlling its speed in one compact unit. Additionally, on some ship consoles, like the one shown in figure 11-2, you will find lighting, steering, and general alarm controls housed in the ship control console.

**Helm Unit:** The helm unit for most ships consists of a wheel, rudder angle indicator, rudder order angle indicator, and synchros that send electrical impulses to the steering units located in the after steering room.

**Lee Helm:** The lee helm unit may be located in the SCC or it may stand alone near the SCC. In any case, it sends information to the engine room to indicate the ship's speed. In general, a speed order is sent from the bridge and then the order is answered by the engine room.

# Bridge Equipment, Continued

---

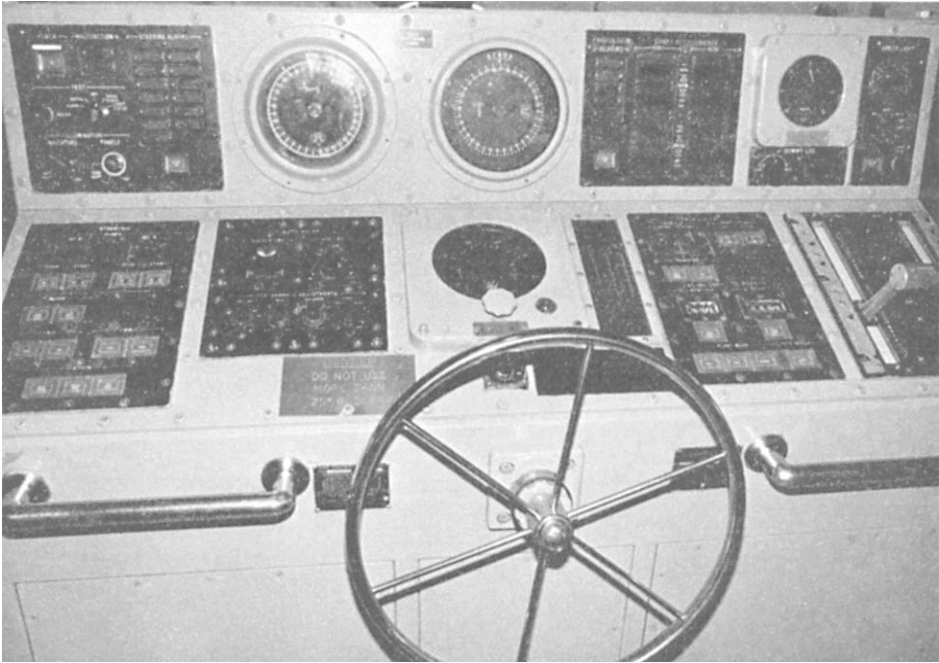

Figure 11-1. DD 963 class ship control console.

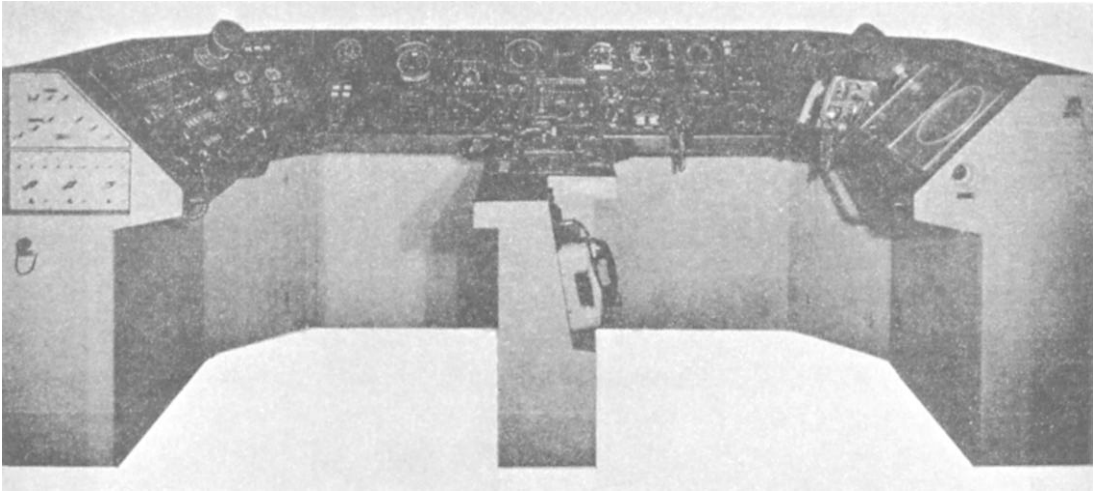

Figure 11-2. FFG-7 class ship control console.



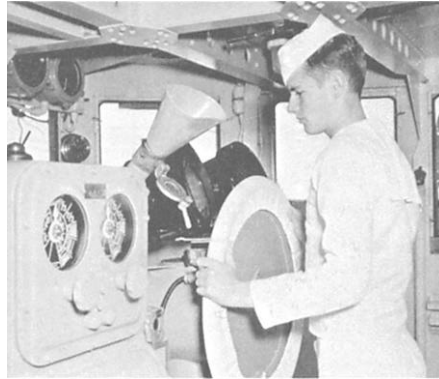
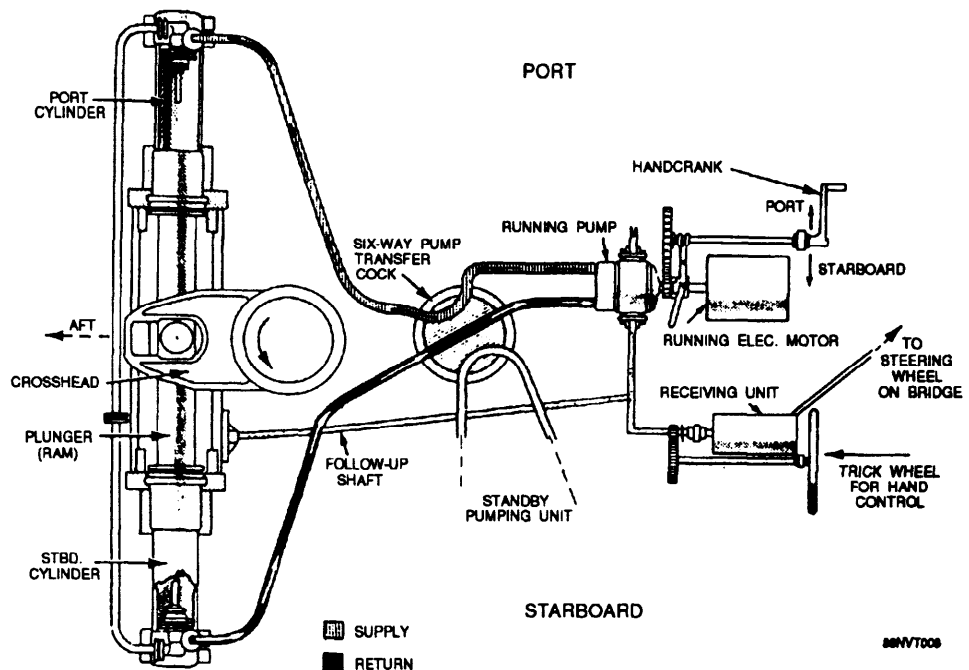

Figure 11-3. Bridge of a destroyer, showing voice tube in front of helmsman..

**Steering Pumps:** Most ships are equipped with a minimum of four steering pumps located in the after steering room. The normal configuration for running are pumps one and three or pumps two and four. The pump units are run at 24-hour intervals and normally switched on the midwatch. The controls for the steering pumps may be located in the SCC. Figure 11-4 shows the port steering gear assembly.



11-4. Port steering gear.

## Bridge Equipment, Continued

---

**Gyrocompass Repeaters:** As you learned in chapter 2, there are several gyro repeaters located on the bridge. In the SCC, there are normally two such repeaters for the helmsman to steer the ship by. One is called the master and receives its signal from the master gyrocompasses. The other is called the auxiliary and it receives its signal from the auxiliary gyrocompass. Also, the magnetic compass is generally located directly behind the SCC where the helmsman can steer by it, if necessary.

**Shifting Steering Control:** In emergency situations, steering control may be shifted to after steering or the secondary conning station. As a rule, whenever the ship is in restricted waters or conducting underway replenishment, after steering will be manned by a master helmsman and helm safety officer. If the helm unit on the bridge were to fail, the helmsman could immediately shift steering control to after steering. Step-by-step instructions for shifting steering control vary from ship to ship. The engineering officer should be consulted for instructions.

**SCC Alarms:** There are several alarms that are located in or near the SCC. Among these, the two most important are the loss of steering alarm and the gyrocompass failure alarm. If either one activates, the OOD should be notified immediately.

# Ship's Characteristics

---

**Fundamentals of Shiphandling** Before we can discuss the techniques used to steer a ship, you'll have to learn the basics of shiphandling. Use the following table and figure 11-5 to learn the terms associated with a ship's characteristics.

Term	Definition
Pivot Point	<p>A ship's pivot point is a point on the centerline about which the ship turns when the rudder is put over. The pivot point scribes the ship's turning circle.</p> <p>A ship's pivot point is nearly always located about one-third the ship's length from her bow when moving ahead, and at or near her stern when moving astern. The location of the pivot point will vary with ship's speed. An increase in speed will shift the pivot point in the direction of the ship's movement.</p>
Turning Circle	<p>A ship's turning circle is the path followed by the ship's pivot point when making a 360 degree turn. The diameter of the turning circle varies with rudder angle and speed. With constant rudder angle, an increase in speed results in an increased turning circle. Very low speed (those approaching bare steerageway) also increases the turning circle because of reduced rudder effect.</p> <p>Knowledge of the turning characteristics of one's ship is essential to safe shiphandling, particularly when in restricted waters.</p>
Advance	Advance is the amount of distance run on the original course until the ship steadies on the new course. Advance is measured from the point where the rudder is first put over.
Transfer	Transfer is the amount of distance gained towards the new course.
Tactical Diameter	Tactical diameter is the distance gained to the left or right of the original course after a turn of 180° is completed.
Final Diameter	Final diameter is the distance perpendicular to the original course measured from the 180° point through 360°. If the ship continued to turn at the same speed and rudder indefinitely, it would turn on this circle. The final diameter is almost always less than the tactical diameter.

## Ship's Characteristics, Continued

Term	Definition																																										
Standard Tactical Diameter	Standard tactical diameter is the specific distance recorded in tactical publications for each ship. It varies with each ship class.																																										
Standard Rudder	Standard rudder is the amount of rudder angle used to make the ship turn in the standard tactical diameter. On most ships, this is equal to 15°.																																										
Angle of Turn	<p>Angle of turn is the angle measured from the point where the rudder was put over to the point where the ship steadies on the new course.</p> <p>For example, if a ship is on course 300° and turns starboard to new course 345°, the angle of turn is 45°.</p> <p><b>Using Turn Bearing:</b> Finding the angle of a turn is necessary for using turn bearings. A turn bearing is a bearing from an ATON on which the ship will put the rudder over to execute a turn. Every ship maintains a tactical characteristics folder, which contains advance and transfer tables as shown in table 11-1. Advance and Transfer tables are used to determine turn bearings. They are entered using the angle of turn and the ship's speed. Actual construction of turn bearings will be covered in chapter 12.</p> <table border="1" data-bbox="906 889 1357 1391"> <thead> <tr> <th colspan="3" data-bbox="906 889 1357 981">STANDARD TACTICAL DIAMETER AT 15 KNOTS REQUIRING STANDARD RUDDER</th> </tr> <tr> <th data-bbox="906 981 1084 1076">Angle of turn (degrees)</th> <th data-bbox="1084 981 1224 1076">Advance (yards)</th> <th data-bbox="1224 981 1357 1076">Transfer (yards)</th> </tr> </thead> <tbody> <tr><td>15</td><td>185</td><td>40</td></tr> <tr><td>30</td><td>275</td><td>85</td></tr> <tr><td>45</td><td>345</td><td>115</td></tr> <tr><td>60</td><td>390</td><td>190</td></tr> <tr><td>75</td><td>445</td><td>270</td></tr> <tr><td>90</td><td>500</td><td>375</td></tr> <tr><td>105</td><td>450</td><td>445</td></tr> <tr><td>120</td><td>405</td><td>520</td></tr> <tr><td>135</td><td>360</td><td>590</td></tr> <tr><td>150</td><td>315</td><td>655</td></tr> <tr><td>165</td><td>265</td><td>725</td></tr> <tr><td>180</td><td>205</td><td>800</td></tr> </tbody> </table> <p style="text-align: right; font-size: small;">26NVM113</p> <p style="text-align: center;">Table 11-1. Sample from Advance and Transfer Tables.</p>	STANDARD TACTICAL DIAMETER AT 15 KNOTS REQUIRING STANDARD RUDDER			Angle of turn (degrees)	Advance (yards)	Transfer (yards)	15	185	40	30	275	85	45	345	115	60	390	190	75	445	270	90	500	375	105	450	445	120	405	520	135	360	590	150	315	655	165	265	725	180	205	800
STANDARD TACTICAL DIAMETER AT 15 KNOTS REQUIRING STANDARD RUDDER																																											
Angle of turn (degrees)	Advance (yards)	Transfer (yards)																																									
15	185	40																																									
30	275	85																																									
45	345	115																																									
60	390	190																																									
75	445	270																																									
90	500	375																																									
105	450	445																																									
120	405	520																																									
135	360	590																																									
150	315	655																																									
165	265	725																																									
180	205	800																																									
Drift Angle	Drift angle is an angle at any point on the turning circle between the intersection of the tangent at that point and the ship's keel line.																																										
Kick	Kick is the swirl of water toward the inside of the turn when the rudder is put over. Also, the momentary movement of the ship's stern toward the side opposite the direction of the turn.																																										

# Ship's Characteristics, Continued

## Discussion

When the rudder is put over in making a turn, the stem is forced away from the direction of the turn. Because of momentum, the ship turns very slowly from her original course for several lengths. She then commences to gain ground in the new direction, moving sideways through the water to a considerable degree. This naturally results in loss of speed and is why, when a column turn is made, a vessel gains rapidly on the ship ahead while that ship is turning, but loses this distance during her own turn when the first ship completes her turn and steadies on the new course.

Each ship should have available on the bridge a folder of the ship's tactical characteristics. It should be carefully studied by all shiphandlers. Pertinent data should also be available at other stations concerned with ship maneuvers, such as the combat information center (CIC).

These tables are drawn up with the ship making several turning runs at different speeds and using various rudder angles.

Table 11-1 is a sample advance and transfer table for a ship making a turn at 15 knots, using standard rudder. Similar tables are compiled for other rudder angles at the same and different speeds. The time required to make the various turns may also be shown.

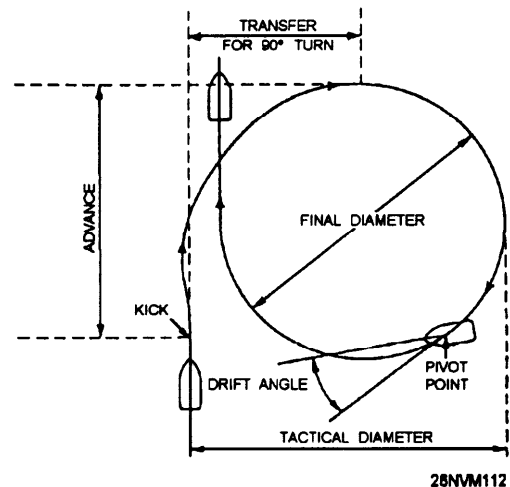

Figure 11-5. Turning circle.

## Acceleration and Deceleration Tables

At times, allowance must be made for the rate at which a ship increases and decreases speed. Another part of the tactical data folder, therefore, is the acceleration/deceleration table, of which a sample is given in table 11-2. Practical examples of its use follow.

**Example 1:** A ship is standing up a channel at 15 knots. The captain desires to maintain speed as long as possible, but must pass an anchored dredge at a maximum speed of 10 knots. Determine how far before reaching the dredge a speed reduction should be commenced.

# Ship's Characteristics, Continued

## Acceleration and Deceleration Tables

From the deceleration table, it is determined that 1 minute is required to decelerate from 15 knots to 10 knots. Because the rate of deceleration is always constant between any two speeds, the average of these two speeds is the average speed of the ship during this time period. By computation, 15 knots plus 10 knots gives an average speed, during 1 minute of deceleration, of 12 1/2 knots. Determination of average speed is the crux of this problem. To compute the distance the ship will travel in 1 minute at 12 1/2 knots, multiply 2,000 (yards) by 12.5 (knots) and divide by 60 (minutes). The result is approximately 417 (yards). Measure back 417 yards along the DR track from a point abeam the dredge. This latter point is where it is recommended that turns for 10 knots be rung up on the engines.

**Example 2:** A ship is proceeding through Ambrose channel at 10 knots. The navigator is informed that 25 knots is to be ordered when the ship clears the channel. One computation is requested by the OOD:

- How far along the DR track will the ship travel from the time 25 knots is rung up until she is making that speed?

- Because the ship is proceeding at only 10 knots, a running tabulation of speeds and times must be considered. Going to the acceleration part of the table, compute the distance traveled in three steps: 10 to 15, 15 to 20, and 20 to 25.

Knots		Minutes		Rate
Change of speed		Time required for change	Total elapsed time	Knots per minute
From	To			
<b>Acceleration</b>				
0	10	3	3	3-1/3
10	15	2	5	2-1/2
15	20	2	7	2-1/2
20	25	5	12	1
25	30	10	22	1/2
<b>Deceleration</b>				
30	25	5	5	1
25	20	3	8	1-2/3
20	15	1	9	5
15	10	1	10	5
10	0	2	12	5

28NVM114

Table 11-2. Sample Acceleration and Deceleration Table

# Steering the Ship

---

**Helmsman and Master Helmsman** In normal steaming conditions, the helmsman is normally a nonrated Seaman from the Deck Department. However, only QMs qualified as master helmsman man the helm during situations where precise shiphandling is required ( unrep, restricted waters, and special evolution). Keeping a ship exactly on course can be a tough job, especially in heavy seas. As you advance to higher paygrades, you will be required to complete PQS and stand watch as helmsman and master helmsman.

The following discussion will cover standard orders to the helm, effects of wind and current, and steering the ship for special evolutions.

**Note:** Conning officers are usually assigned from the ranks of junior officers. Increasingly, senior QMs are tasked with standing watch as conning officer and even OOD on smaller ships. The study of shiphandling theory is highly encouraged. A excellent reference is *Crenshaw's Naval Shiphandling*.

---

## Standard Helm Orders

### Rules:

- The courses the helmsman steers must be ordered by the conning officer. The helmsman should have the ship on course before he or she surrenders the wheel to his or her relief. This does not apply to master helmsman.
- The words *port* and *starboard* are never used when giving orders to the helmsman. When an order necessitates a change of rudder angle to right or left, the direction of change is always stated, such as **right** full rudder.
- The helmsman always repeats all orders back to the conning officer, as they were given (word for word). Standard orders to the helmsman and their corresponding meanings are as follows:

Helm Order	Action
RIGHT (LEFT) STANDARD RUDDER	Varies on different ships (usually 15° rudder). It is the designated number of degrees of rudder angle that causes the ship to turn within a prescribed distance called standard tactical diameter. You must find out what standard rudder is on your ship.
RIGHT (LEFT) FULL RUDDER	Usually means 30° on the rudder angle indicator.

## Steering the Ship, Continued

Helm Order	Action
RIGHT (LEFT) HARD RUDDER	Normally equal to 35° of rudder.
COME RIGHT (LEFT) TO 148°	Means to swing the ship's head in the direction stated and steady it on the course given; in this example, 148°. The order is frequently stated "COME RIGHT (LEFT) TO 148°."
STEER 190°	Usually given for only a minor change of heading to the number of degrees specified.
STEADY ON 225°	States the course on which the ship's head is to be steadied. It is normally given while ship's head is swinging. You may use up to 30° of opposite rudder to steady the ship.
INCREASE YOUR RUDDER	Means to increase the rudder angle and is usually ordered when the conning officer wants the ship to move more rapidly. May be given as a specific amount such as increasing to right full rudder.
EASE YOUR RUDDER TO (SPECIFIED) DEGREES	Signified to reduce the rudder angle. It may be given as "EASE TO 15° (10° 20° RUDDER" or "EASE YOUR RUDDER TO RIGHT 15)."
RUDDER AMIDSHIPS	Means to put the rudder on the centerline; no rudder angle. As a rule, this order is merely "RUDDER AMIDSHIPS!"
MEET HER	Means to check the swing by putting on opposite rudder.
STEADY AS YOU GO	Means to steady the ship on the course it is heading at the time the order is given. If the ship is swinging at the time, heading must be noted and the lubber's line brought back to and steadied on it as soon as possible. The order is also stated as "STEADY," or "STEADY AS SHE GOES."
SHIFT YOUR RUDDER	Commands you to change to the same number of degrees of opposite rudder angle.
MIND YOUR RUDDER!	A warning that the ship is going off the course because of bad steering.
NOTHING TO THE RIGHT (LEFT) OF (SPECIFIED HEADING)	Given when the presence of some danger on one side or the other makes it necessary to avoid a set in that direction.
KEEP HER SO	Continue to steer the course you are heading. Usually given after you state the course you are steering.
MARK YOUR HEAD	A statement to the helmsman. He or she should give the ship's head at the time of the command, for example, "two seven five, sir."
VERY WELL	Reply of conning officer to helmsman, meaning that the response is understood.



## Steering the Ship, Continued

---

### Techniques

The helmsman must repeat distinctly, word for word, every order he or she receives. This is done so the conning officer knows the helmsman understands his or her command. To respond to an order such as STEADY AS YOU GO, follow the repeating of the order with the reply STEADY ON 110, or whatever the course was you marked when you received the order. Do this once the ship steadies up.

As a master helmsman, you must know more about how your ship steers than anyone else. Every ship handles differently. Many hours on the helm will allow you to anticipate how the ship will react. Here are some tips, which were gathered from senior Quartermasters concerning steering the ship.

**General Techniques:** The first rule that you must follow is to pay attention at all times! Many helmsmen have found themselves in a world of trouble because they lost focus, and then chased the helm. This is how ships become damaged (which the U.S. Navy frowns upon).

Never oversteer. Steering a ship is often a situation where less is more. Always use the least amount of rudder necessary to maintain course. Be patient, the ship will respond. A common mistake is to use more rudder than needed to maintain course, which results in a snaking effect.

On the other hand, use the rudder when needed. Commands like MEET HER and STEADY AS YOU GO warrant the use of rudder up to 30°, if necessary. Other ships in formation judge another ship by the way she makes her turns. Make sure your ship turns smartly. Quick and precise maneuvers are the name of the game!

Find the weather helm: If you were to leave the rudder amidships (0°), the wind, current, and even the ship's list would put you off course. Before relieving the helm, make a habit of observing the swell and wind waves. Then, always ask what rudder combinations are currently being used to maintain course. For example, if the wind and swell is hitting the ship on the port bow at 45°, the stem will be pushed to the right. This action could cause the ship to fall off course to the left. Knowing this, you could imagine that some amount of right rudder will be required to maintain course. When finding the weather helm, you are actually looking for the amount of rudder that is a real time 0°.

The weather helm varies with the weather and currents. If it takes a constant 2° of right rudder, then the weather helm equals 2° right, which is the same as 0° with no wind or current.

## Steering the Ship, Continued

---

**During UNREP** Steering the ship during underway replenishment is no simple task. There are more factors to consider other than wind and current. When two ships are alongside, a vortex effect is created. This vortex works like a cushion between the two ships, normally pushing them apart slightly. Also, when the rigs are tensioned, the ships are pulled together slightly.

Close attention to keeping the ship exactly on course cannot be stressed enough. Use the least amount of rudder to accomplish this. Often, the master helmsman will be required to steer courses on 0.5 degrees such as 010.5. While unreping .5° is the maximum deviation allowed from ordered course. Also, ships alongside often make turns while rigs are hooked up. This requires the ship on the outside of the turn to slightly increase speed. This type of maneuver is normally completed in 5-degree increments until the final course is reached.

Prior to beginning a UNREP, the bridge watch team should go over emergency procedures for loss of steering.

---

**In Restricted Waters** Steering the ship in restricted waters requires precise shiphandling. As with UNREP evolutions, every effort must be made to stay exactly on ordered course. Often the ship will be transiting narrow channels where tidal currents may be strong. This is not much of a problem when the bow is pointed into the current; however, a strong current from astern can cause the bow to fall off course. This is especially true when the ship's speed is 10 knots or less.

---

**During Special Evolutions** Special evolutions include general quarters, launching of amphibious craft, or whenever the OOD or navigator requires that the more experienced master helmsman man the helm.

---

**From After Steering** Steering the ship from after steering requires total concentration. This is due mainly to the fact that there is nothing to see and the trick wheels used to move the rudders face towards the stem. If steering control is lost on the bridge, steering control will be shifted to the after steering helmsman. The after steering helmsman will receive orders directly from the conning officer (relayed by the helm safety officer) or from the rudder angle order indicator.

# Navigational Lights

---

## Rules of the Road

According to the Rules of the Road, every ship is required to display navigational lights. The Quartermaster is responsible for turning on the ship's running lights at sunset and during periods of reduced visibility and for turning them off at sunrise.

---

## Navigational Light Panel

The ship's running lights consist of the forward mast light, the after mast light, the port and starboard side lights, and the stem light. A typical running light control panel is shown in figure 11-6. Before turning these lights on, you should test each light by pressing the test button with all power switches on. Above the test button there are two indicator lights. Each running light has a primary and a secondary filament. When you are testing the lights and a red indicator light comes on, this means the primary filament is burned out, and the light should be replaced by an Electrician's Mate. Under most conditions, you should turn on all of the light switches, leaving the master switch off. When you are ready to energize the lights at sunset, turn on the master switch and all the ship's running lights are energized at the same time.

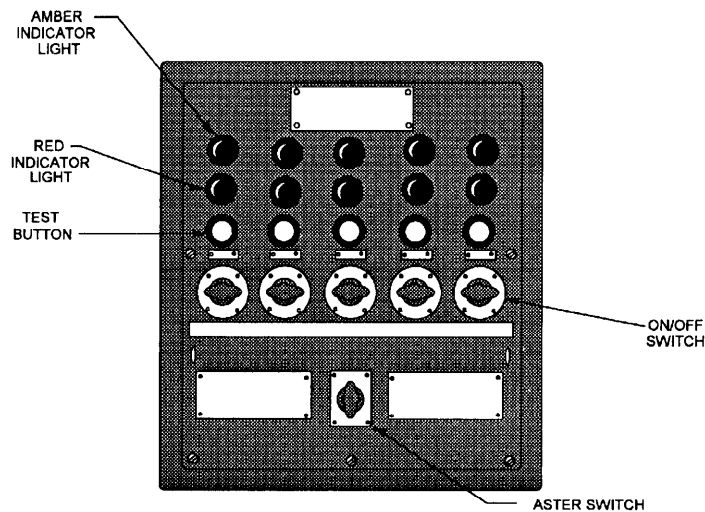

26NVM115

Figure 11-6. Running light control panel.

---

## Special Lighting Control Panel

In addition to being familiar with the normal running light control panel, the Quartermaster must also be familiar with the operating of the special lighting control panel. A description of the lights on the special lighting control panel follows. Refer to figure 11-7.

# Navigational Lights, Continued

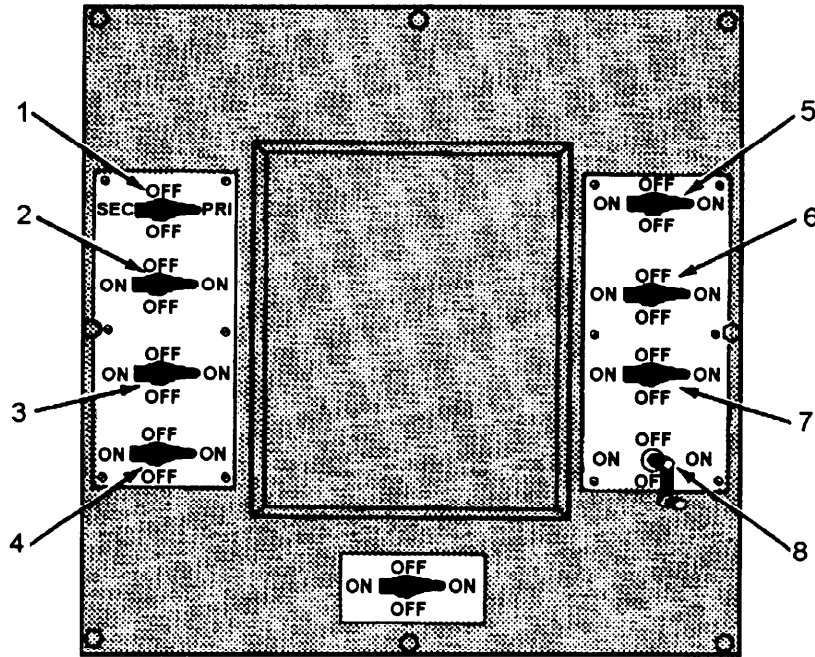

26NVM116

Figure 11-7. Special light control panel.

NOTE: The panel position of the switches for the various lights may vary by ship type.

Name	Description	Energized When
1. Wake Light	The wake light (white) for ships is installed on the fantail or afterpart of the ship to illuminate the wake. It is mounted so that no part of the ship is illuminated. The fixture is watertight and of tubular construction. The wake light, like the running lights, has a two-filament bulb with a primary and secondary switch position on the control panel.	Engaged in towing operations or whenever the wake needs to be illuminated.

## Navigational Lights, Continued

Name	Description	Energized When
2. Blinker	The blinker lights are located on the yardarms and are used for sending flashing light. The blinker lights are used with signal keys, which are normally installed on the bridge and signal bridge. The blinker light switch must be in the ON position for the signal key to be activated.	Used as an alternative method of sending flashing light at night.
3. Aircraft Warning	The aircraft warning lights are 360° red lights. They are installed at the truck of each mast that extends more than 8 meters (26 feet) above the highest point of the superstructure. Two aircraft warning lights are installed if the one light cannot be seen throughout 360°. If two masts are tall enough to require these lights but are less than 15 meters apart, they will be installed only on the higher mast.	From sunset to sunrise when your ship is at anchor or moored.  When operating aircraft at night.
4. Not Under Command/ Man Overboard	The crank/switch controls a pair of red lights that have multiple uses. The lights are located 6 feet apart (vertically) and mounted on brackets that extend abaft the mast or structure and to port thereof. This mounting arrangement permits visibility, as far as practicable, throughout the 360° arc.	<u>Not Under Command</u> --When the switch is in the ON position, it turns on the red lights, which indicate that your ship has had a breakdown.  <u>Man Overboard</u> --When the switch is continually turned ON and OFF by use of the crank, it causes the pair of red lights to blink ON and OFF (pulsate), indicating that your ship has a man overboard.

## Navigational Lights, Continued

Name	Description	Energized When
5. Task	The proper light signal to let other ships know that your ship cannot easily maneuver is red-white-red. If you turn on the lights as you would to indicate that your ship is broken down and add a white light in the center, this will give you the proper lights. The required white light is mounted in the center of the <u>Not Under Command/Man Overboard</u> lights, and the controlling switch is mounted on the bulkhead in the vicinity near the special lighting control panel.	Whenever the ship is in a situation where it cannot easily maneuver. For example, when a ship is alongside another ship taking on food, fuel, or ammo, it is involved in a task and cannot maneuver easily. Also used when a ship is constrained by its draft.
6. Blue Stem	The blue stem light is a light similar to the white stem light the ship uses for normal running lights.	Your ship is engaged in convoy or formation steaming during periods of darken ship. It is also used when engaged in some forms of plane guard duty during recovery/launch flight operations.
7. Anchor Aft	The after-anchor light is a 360° white light mounted at the top of the flagstaff.	From sunset to sunrise and during periods of reduced visibility when your ship is at anchor or moored.
8. Anchor Forward	The forward anchor light is a 360° white light mounted at the top of the jackstaff. It is used at the same time as the after-anchor light.	Same as above.
Not Shown: ASW Light [Grimes light)	The ASW light is a colored light, visible as nearly as practical, all around the horizon. Each ship is provided with two red, two green, and two amber lenses. The ASW light is installed on all ASW-capable ships. The color to be used is determined by the squadron commander. The ASW light is installed on either the yardarm or mast platform where it can be seen all around the horizon.	Conducting ASW operations.

# External Communications

---

## Methods

There are several ways by which to communicate with other ships and shore commands while at sea. One of the oldest is communicating by flaghoist using signal flags. The newest methods incorporate the use of satellite uplinks to transfer data. The objective of the material presented in this section is to give you a basic knowledge of methods of communicating. You will be referred to reference material for instructions concerning each method.

The following table gives you a snapshot of different methods used to communicate while at sea.

Method	Description
VHF Radio (Electronic)	The VHF radio commonly refer to as the bridge-to-bridge circuit is often used to exchange unclassified information between ships. All vessels over 100 meters in length are required to be equipped with VI-IF capability.
Radiotelephone (R/T) (Electronic)	When conducting operations, the RT circuits are probably the most frequently used method of communicating. Each ship involved is assigned a call sign. There are normally at least two secure frequencies assigned for any operation by the officer in tactical command (OTC). One frequency is used for encoded tactical signals, while the other is used for secure plain voice communications.
Flaghoist (Visual)	<p>Tactical and information signals are communicated using signal flags. The flags and pennants are divided into two flag bags. The allied bag contains 68 flags and pennants that are used to communicate with other naval ships. The international flag bag contains 40 flags and pennants that are used to communicate with merchant ships.</p> <p>Flaghoists are always read from the top outboard side then down and inward. In other words, if three hoists are closed up (at the top of the halyard) start at the top outboard side and read down, then go to the top of the next inner hoist and again read down, and so on.</p> <p>Signalmen make up and execute flaghoist messages or signals as directed by the OOD.</p>

## External Communications, Continued

---

Method	Description
Flashing Light	Searchlights equipped with special shutters and red lenses are used at night to send messages or signals. Standard Morse code is transmitted to the receiving ship by Signalmen
Semaphore	Semaphore is much faster than flashing light when transmitting messages over a short distance. It is normally used while ships are alongside conducting UNREP.  Signalmen send the messages using hand flags or light wands.

---

### Responsibilities

As you continue to advance as a QM, you will be required to gain experience in the use of the methods of external communication as listed. As a PO2 or PO3, you are required to be able to read signal flags and pennants. As step-by-step instructions are given in ACP 129, *Communication Instructions, Visual Signalling Procedures*, they will not be repeated here.

At the PO1 and higher paygrades, you are required to encode and decode tactical signals. Instructions to meet this requirement are found in ATP, *Allied Tactical Publication 1B, Volumes I and II*. OJT is really the only way to become proficient at encoding, decoding, and transmitting tactical signals. The navigator can normally set up training through the operations boss on this material.

### Exchanging Navigational Data

Occasions will arise when the exchange of navigational data with other ships is necessary. In general terms, a position, time of position, and course and speed are all that is required. Navigational data must never be exchanged on unsecured frequencies. Always notify the navigator when an exchange of navigational data is requested.



# Bridge Watch Personnel

---

The numbers and assignments of personnel on watch vary from ship to ship, depending on the ship's size and availability of personnel.

The watch on the bridge, under way, normally consists of the following personnel:

Officer of the deck (OOD)

Junior officer of the deck (JOOD)

Quartermaster of the watch (QMOW)

Boatswain's mate of the watch (BMOW)

Helmsman

Lee helmsman (who mans the engine order telegraph and RPM indicator)

Sound-powered telephone talker

Messenger

Lookouts

In the following text, we will discuss the duties of the OOD, BMOW, and helmsmen. The Quartermaster, as an assistant to the OOD, must know the duties of all bridge personnel.

---

## **Officer of the Deck**

The officer of the deck under way is designated in writing by the commanding officer and is primarily responsible, under the commanding officer, for the safe and proper operation of the ship.

The following is a list of the OOD's primary duties as prescribed by the *Standard Organization and Regulations of the US. Navy*, OPNAVINST 3120.32. The officer of the deck under way will:

1. Keep continually informed concerning the tactical situation and geographic factors that may affect the safe navigation of the ship, and take appropriate action to avoid the danger of grounding or collision according to tactical doctrine, the Rules of the Road, and the orders of the commanding officer or other proper authority.

## Bridge Watch Personnel, Continued

---

### Officer of the Deck, continued

2. Keep informed concerning current operation plans and orders, intentions of the OTC and the commanding officer, and such other matters as may pertain to ship or force operations.
3. Issue necessary orders to the helm and main engine control to avoid danger, to take or keep an assigned station, or to change the course and speed of the ship according to orders of proper authority.
4. Make all required reports to the commanding officer. When a command duty officer is specified for the watch, he or she will make the same reports to the command duty officer.
5. Ensure that required reports to the OOD concerning tests and inspections and the routine reports of patrols, watches, and lifeboat crews are promptly originated and that the bridge watch and lookouts are properly posted and alert.
6. Supervise and direct the personnel on watch on the bridge, ensure that all required entries are properly made in the Ship's Deck Log, and sign the log at the conclusion of the watch.
7. Issue orders for rendering honors to passing ships as required by regulations and custom.
8. Ensure that the executive officer, command duty officer (when assigned), and department heads concerned are kept informed of changes in the tactical situation, operation schedule, the approach of heavy weather, and other circumstances that would require a change in the ship's routine or other action on their part.
9. Keep informed of the status and current capabilities of the engineering plant and keep the engineering officer of the watch advised concerning boiler power requirements and the operational situation so that he or she may operate the engineering plant intelligently.

## Bridge Watch Personnel, Continued

---

### Officer of the Deck, continued

10. Carry out the routine of the ship as published in the plan of the day and other ship's directives, keeping the executive officer advised of any changes that may be necessary.
11. Supervise and control the use of the general announcing system; the general, chemical, collision, sonar, and steering casualty alarms; and the whistle according to the orders of the commanding officer, tactical doctrine, and the Rules of the Road.
12. Permit no person to go aloft on the masts or stacks or to work over the side except when wind and sea conditions will not expose him or her to danger; and then only when all applicable safety precautions are observed.
13. Supervise and control all transmissions and acknowledgments on the primary and secondary tactical voice radio circuits, and ensure that proper phraseology and procedures are used in all transmissions.
14. Supervise and conduct on-the-job training for the JOOW, the JOOD, and enlisted personnel of the bridge watch.
15. Assume such other responsibilities as may be assigned by the commanding officer.
16. Supervise the striking of the ship's bell to denote the hours and half-hours from reveille to taps, requesting permission of the commanding officer to strike eight bells at the hours of 0800, 1200, and 2000.
17. On ships that do not station a damage control watch officer, supervise the maintenance of a log of all fittings that are in violation of the material condition of readiness prescribed. Entries will show the name and rate of the person requesting permission to open a fitting, approximate length of time to be open, and time closed. Anyone who, without permission, violates the material condition of readiness in effect shall be made the subject of an official report.

As you can see from the list of duties, the OOD can be a very busy person. This is especially true when your ship is operating in company with other ships or close to a shipping lane. For this reason, you, as the Quartermaster of the watch, can be of great assistance to him or her. The QMOW is the direct assistant to the OOD.

## Bridge Watch Personnel, Continued

---

### **Junior Officer of the Deck / Conning Officer**

On many ships, the JOOD and conning officer watch stations are manned by one person. In this capacity the JOOD maintains a constant watch on all radar contacts along with CIC personnel. He or she receives reports on contacts from lookouts and gives orders to the helmsman and lee helmsman. The JOOD also encodes, decodes, transmits, and receives tactical signals and acts as an assistant to the OOD.

---

### **Boatswains Mate of the Watch (BMOW)**

The BMOW is in charge of the underway watch section. The status of the BMOW in this respect is the same whether the ship is in condition of readiness I, II, or III, or the regular sea watch or in-port watch has been set.

The normal peacetime underway watch for which the BMOW is responsible consists of the helmsman, lee helmsman, messenger, lookouts, lifebuoy watch, and lifeboat crew of the watch. Besides being an enlisted assistant and executive arm of the OOD, the BMOW is the watch PO. It is the responsibility of the BMOW to make sure that all deck watch stations are manned and that all personnel in the previous watch are relieved. The BMOW makes a report to the OOD when the deck watch has been relieved.

The ship's organization and regulations manual shows the sea watch stations that must be manned and the divisions required to man them. From this, the BMOW knows which division section leader must be contacted if any person fails to report at his or her watch station.

**Helmsman:** The helmsman is responsible for keeping the ship on course as directed by the conning officer.

**Lee Helmsman:** The lee helmsman is responsible for operating the engine order telegraph (EOT) and relaying information between the bridge and main control.

**Lookouts:** There are normally three lookouts assigned to each watch section. One stationed on the port bridgewing, one on the starboard bridgewing, and one aft on the fantail. Each lookout is responsible for reporting any contacts or objects in the water to the OOD immediately. The aft lookout also watches the wake for personnel who may have fallen overboard.

# Relieving the QMOW

---

## Relieving the Watch

Always arrive on station ahead of the scheduled time for relieving the watch. There is nothing more unprofessional and aggravating than a late relief. More importantly, you must obtain much information about the general situation before you can assume the watch. The general pattern of relief is as follows:

One-half hour before the hour, the relief arrives on station. The relief will make inspection, read logs and turnover sheets, and obtain other information from watch standers. Fifteen minutes before the hour, watch standers are relieved.

When you relieve the watch, make sure you obtain all information the person you relieve may have for you. Such information includes verbal orders to the wheel that still are standing, steering peculiarities because of unusual weather situations, or anticipated aids to navigation.

When you arrive on the bridge, you must assess the general situation. You should have a good knowledge of what is happening aboard your ship. How much information you need depends to some degree on the situation your ship is in at the time. If you are in company with other ships, you will need much more information than you would if you were steaming independently. Never relieve the watch until you have been briefed on the ship's position and turning or rendezvous points. Additionally, you should sight all navigational aids (visual, radar, or other electronic means) that are being used to fix the ship's position.

Look over the Ship's Deck Log entries of the previous watch and see if there is anything pertaining to your watch. Report officially to the OOD that you have relieved the watch. As previously mentioned, you serve as the assistant to the OOD. In this capacity, you are very close to events occurring on the bridge and at other stations. Your nearness makes it possible for you to observe the watch personnel and the jobs they are performing. Frequently, the OOD is involved in a problem with maneuvering or navigation and may fail to notice the omission of small details in the ship's daily routine. The plan of the day or pages from the ship's organization book listing the routine of the day are available in the pilothouse. It is an important part of your job as QMOW to remind people concerned when the time approaches for performing each detail.

# Commanding Officers Night Order Book

---

## General Information

The navigator is also responsible for the preparation of the CO's night order book. Night orders are the captain's orders of how he or she wants the ship run when he or she is not on the bridge. The book is normally divided into two separate parts: standing orders and night orders.

Standing orders are the commanding officer's statement concerning his or her policies and directions under all circumstances. Night orders, written on a daily basis, are a summary of tactical, navigational, and readiness information for bridge watch standers. Additional information and guidance are added by the captain and the navigator.

Prior to writing the night orders, the navigator reviews the ship's operational orders and the nightly schedule of events for anticipated evolutions or activities. Should any conflicts exist between the schedule of events and the standing orders, the navigator informs the commanding officer.

The navigator then writes the night orders for the commanding officer, providing ship's information and operational data, including anticipated evolutions and a schedule of events, if needed. The commanding officer then adds his or her remarks and the night order book is placed on the bridge.

Among the watch standers required to read and initial are the OOD, JOOD, BMOW, and QMOW. This initialing ensures that the orders have been read and understood.

# The Ship's Deck Log

---

## **Maintaining the Ship's Deck Log**

As QMOW, one of your duties is to act as an observer and recorder. There are many logs and records that you must maintain. Probably the most important log will be the Ship's Deck Log. The basic requirements for maintaining the Ship's Deck Log are contained in U.S. Navy Regulations, 1973, and OPNAVINST 3120.32 series.

We will discuss the general policy and regulations, the form preparation, the assembly and disposition procedures, the abbreviations, and the required entries in the Ship's Deck Log.

---

## **General Policy and Regulations**

All U.S. Navy ships in commission and other craft, as required, must maintain a Ship's Deck Log. The deck log is the official daily record of a ship by watches. Entries should describe every circumstance and occurrence of importance or interest that concerns the crew and the operation and safety of the ship. Entries should also include information that may be of historical value.

The deck log must be a chronological record of events occurring during the watch that will meet the needs of the commanding officer. Additionally, the deck log, will provide a document of historical, value. Accuracy in describing events recorded in a Ship's Deck Log is a must. Deck log entries often make important legal evidence that may be used in judicial and administrative fact finding proceedings arising from incidents involving the ship or its personnel.

Under certain circumstances, such as limited local operations of service craft, the maintenance of a deck log is not required. However, other adequate records of events must be maintained by the command. If doubt exists as to whether a deck log is required, the facts must be submitted to the Chief of Naval Operations (CNO) for a determination.

The Ship's Deck Log must be "unclassified" except when another classification is required by security regulations such as wartime operations, special operations, and so forth. Basically, information in the Ship's Deck Log is FOR OFFICIAL USE ONLY.

# The Ship's Deck Log, Continued

---

## Form Preparation

All ships must prepare an original and one copy of the deck log. The original log must be submitted monthly to the CNO for permanent retention. The copy must be retained on board for a period of 12 months, after which time it may be destroyed.

Sample entries should be used as guides for recording the remarks of a watch. Entries, such as reveille, meals for the crew, payday, and so forth, which would not serve any useful purpose or add to the historical value of the log, are not required.

All entries in the Ship's Deck Log must be made with a ballpoint pen, using black ink. The Quartermaster of the watch, or other designated watch personnel, must write the log of the watch legibly. Each event must be recorded at the time it happens or as directed by the OOD, who will supervise the keeping of the log .

Most ships normally adhere to a 4-hour watch schedule (00-04, 04-08, 08-12, and so on.), but note as follows: uniform time segments for the scheduling of watches are prescribed for the deck log. The remarks in the deck log must be recorded daily by watches that consistently adhere to the individual ship's schedule. The circumstances under which a ship is not required to make entries daily by watches can be found in OPNAVINST 3100.7.

The top of each form must be filled in as follows:

1. In spaces 3 and 4 (fig. 11-8), enter the first two letters of the ship type, and enter remaining letters, if any, in the next two shaded unnumbered spaces. In spaces 5 through 7, enter the ship's hull number. Use leading zero, as required. If the hull number consists of four digits, enter the first digit in the shaded unnumbered space.
2. In box 12, enter the last digit of the month; for example, 02 for February. In box 15, enter the letter designation for the time zone used to record time entries. In boxes 16 and 17, enter two digits for the day of the month.
3. In the space provided, enter the ship's position, latitude, and longitude at the hours of 0800, 1200, and 2000. This entry should be made each day during underway periods. Indicate the type of fix by entering that number from the legend to the right.



# The Ship's Deck Log, Continued

OPNAV 3100/99 (Rev. 1-77)  
S/N 0107-LF-031-0496

## SHIP'S DECK LOG SHEET

SAMPLE ENTRIES

USE BLACK INK TO FILL IN THIS FORM

SHIP TYPE D A F F	HULL NUMBER 170	YEAR 10	MONTH 01	ZONE Q	DAY 05	E	USS <u>LINDERWOOD</u>	CLASS U	HAND 70
							AT/PASSAGE FROM <u>NORFOLK, VA</u>		
							TO <u>LA CAPEZ DE AREA</u>		

POSITION	ZONE	TIME	POSITION	ZONE	TIME	POSITION	ZONE	TIME	LEGEND
0800			1200			2000			1-CELESTIAL 2-ELECTRONIC 3-VISUAL 4-D.R.
L _____ BY _____			L _____ BY _____			L _____ BY _____			
A _____ BY _____			A _____ BY _____			A _____ BY _____			

TIME	ORDER	CSE	SPD	DEPTH	RECORD OF ALL EVENTS OF THE DAY
16-21	22-29	30-32	33-36	37-40	41
					00-04
2342					Assumed the watch. Passed pastiche to USS ROYAL (DD-000) at 0113, 0113, 0113, Naval Operating Base, Norfolk, Virginia, with standard morning line down, and spring lay out for yard lift. Receiving miscellaneous information from the pier. Cold in air and security watches have been posted. Material conditions YAKG have been set throughout the ship. All present include 700000 units of the U.S. Atlantic Fleet. SOPA in Com. SECOND PWT embarked in USS PENNINGTON (AN-00).
2345					Security watch reports all conditions normal.
2359					Security watch reports all conditions normal.
2345					Relieved by LT JG W.J. TIGER R. P. Day R. C. FOX, BTC, USN
					04-08
0345					Assumed the watch. Passed on before.
0358					Security watch reports all conditions normal.
0506					Security watch reports all conditions normal.
0725					Relieved by LT N.A. TROUT. W. J. TIGER W. J. TIGER, LTJG, USN
					08-12
0725					Assumed the watch. Passed on before.
0830					Captain arrived on board.
0910					Received fuel, water and draft reports. Draft fwd. 13' aft. 14' D. 11' 9" 13' 9"
0930					Stationed the special ops detail.
0931					Relieved by LT E.D. SEADRAGON D. P. Day N. A. TROUT, LT, USN
					08-12 (Portland)
0931					Assumed the watch.
0950					Captain and Navigator are on the bridge.

REPORT SYMBOL OPNAV 3100-10

28NVM117

Figure 11-8. Sample of the Ship's Deck Log.

# The Ship's Deck Log, Continued

---

## Form Preparation

Make entries in the columns of the log as follows:

1. TIME: Enter the exact time of occurrence of event(s) being recorded.
2. ORDER: Enter the standard abbreviation (maximum of seven characters) for orders requiring course, speed, or depth changes. Standard abbreviations will be discussed later in this chapter. Orders consisting of more than seven characters are to be recorded in the **EVENTS OF THE DAY** column.
3. COURSE, SPEED, DEPTH: Enter the changes resulting from an **ORDER**. Example: after a rudder order and the ship is steady, the resulting course should be entered.
4. RECORD ALL EVENTS OF THE DAY: All entries in the Ship's Deck Log must be printed clearly and legibly. The remarks for each event must commence on the line entry of the time of the occurrence. When necessary, the remarks will be continued on succeeding lines. Ships, other than submarines, must start recording the events of the day in the **DEPTH** column.

Rewriting of the deck log sheets should not be required. When necessary, corrections to log entries must be accomplished according to the following procedures:

1. When a correction is deemed necessary, a single straight line must be drawn through the original entry so that the entry remains legible. The correct entry must then be inserted in such a manner as to ensure clarity and legibility. Corrections, additions, or changes must be made only by the individual required to sign the record for the watch and must be initialed by that individual in the left margin of the page.
2. When the commanding officer directs a change or addition to a log entry, the individual responsible for the watch must comply. If the individual responsible for that watch believes the change or addition to be incorrect, the commanding officer must enter the change or addition on the log over his or her own signature.

Only the OOD must sign the log following the last entry made during a watch. The name of the OOD must also be stamped or printed beneath the signature. Facsimile signatures are not acceptable.

# The Ship's Deck Log, Continued

---

## Deck Log Disposition

A Ship's Deck Log Title Page must be completed and attached to each original and duplicate monthly log. The front and reverse sides of each original log sheet may be used for either continuation of entries for a day or for commencing entries for a new day. Ships that are directed to prepare a duplicate copy for antisubmarine warfare (ASW) data must start a new page when the day or time changes

When a ship is directed to provide a duplicate copy of the log for specific ASW missions, two duplicate Ship's Deck Log sheets must be prepared in the following order:

1. The FIRST duplicate copy must be provided for ASW systems evaluation use.
2. The SECOND duplicate copy must be retained on board ship.

The navigator must examine the Ship's Deck Log daily and take such corrective action as may be necessary and within his or her authority to ensure it is properly kept. When each month's log is complete, the navigator must certify the correctness of its contents. This certification should be made in the space provided on the Ship's Deck Log Title Page. Daily signature of the navigator is not required.

The commanding officer must approve the log at the end of each month, when relieved of command, or when the ship is decommissioned. The commanding officer must signify approval by signing the Ship's Deck Log Title Page in the space provided. Both the original and duplicate logs must be signed. When a change of command occurs during the month, the log title page for that month must bear the signatures of each commanding officer. Additionally, the date of the change of command should be entered. The log must not be terminated for submission upon a change of command and must be submitted in its entirety at the end of the month.

Each month's log must be assembled beginning with the title page, followed by the deck log sheets. The deck log sheets should be unnumbered and in chronological order. The log pages for the month must be secured by round head paper fasteners or ribbon. Staples or other types of permanent binding must not be used.

## The Ship's Deck Log, Continued

---

### **Assembly and Disposition**

On the first day of each month or within 10 days thereafter, the original deck log for the previous month must be forwarded directly to the CNO. If required, the original deck log must be forwarded to the CNO by way of the administrative commander. Unclassified logs must be forwarded to the CNO by First Class Mail. Classified logs must be forwarded in the manner prescribed in OPNAVINST 5510.1F.

Ships on extended patrols or conducting special operations and unable to submit logs as required must do so within 10 days after reaching port.

The duplicate deck log provides a temporary record for shipboard use and for the reconstruction of events. It must be retained on board for a period of at least 12 months, after which time it may be destroyed.

When duplicate deck log sheets are required for ASW data use, instructions for those sheets should be provided by the directing commander.

When the original log or any portion of the log is withheld for any legal proceedings, the CNO must be notified. Specific guidelines for using the deck log in any legal matter can be found in the *Manual of the Judge Advocate General*, JAGINST 5800.7B.

---

### **Standard Abbreviations**

There are several abbreviations that are allowed in the ship's deck log. Entries such as A/A/Full for all engines ahead full or R/AMID for rudder amidships are completely acceptable. The deck log instruction contains a complete list of frequently used abbreviations.

# The Ship's Deck Log, Continued

---

## Required Log Entries

As previously stated, events that serve no useful or historical purpose should not be logged. This statement is not meant to minimize deck log entries to the extent that an important event might be omitted. If there is any doubt as to whether or not an event should be logged, the best rule to follow is log it. You can always get guidance on the event in question at a later time. It is easier to delete an event than to add an event. The following is a partial list of required deck log entries. The complete listing of 31 required entries is contained in the deck log instruction and should be consulted when necessary.

1. Every injury, accident, or casualty, however slight, among the officers, crew, passengers, visitors, longshoremen, harbor workers, or repairmen on board must be recorded. The large number of claims for pension or other compensation submitted by persons alleging injury makes this information of great importance to the government. This information serves both to protect the government from false claims and to furnish a record for bona fide claims. Care must be taken to record the full particulars in each instance.
2. All peculiar or extraordinary appearances of the sea, atmosphere, or heavens, preceding or following sudden changes of wind, heavy squalls of wind, or of heavy gales.
3. All unusual appearances of the sea, tide rips, discolored water, extraordinary luminescence of the sea, strange birds or fish, icebergs, driftwood, seaweed, and so forth.
4. All unusual meteorological phenomena, extraordinary refractions, waterspouts, meteors, shooting stars, auroras, halos, fata morganas, iceblinks, corposantos, and all Earth satellites.
5. The behavior of the vessel under different circumstances of weather and sea, such as pitching, rolling, weathering qualities, and so forth.
6. The sighting of vessels, land lighthouses, lightships, and all dangers to navigation, with time, bearings, and distances.
7. The bearing and distance of the object taken for a departure.
8. Any sounding, the record of which is important with the character of the bottom.

# General Duties of the QMOW

---

## General Duties

You will spend many hours standing watch as QMOW on the bridge. Your duties are diverse and at times difficult; this is especially true when you are operating with other ships. In this section of the chapter we will begin to put together topics covered in other areas of the book. The overall goal is to show practical application of what you have learned and introduce you to a few new topics.

The general duties of the QMOW are:

- Maintaining the DR plot and updating the ship's position.
- Recording entries in the Ship's Deck Log.
- Observing and reporting the weather.
- Assisting the OOD.

Let's take a look at what is required of the QMOW.

---

## Fixing the Ship's Position

The ship's position must be determined and plotted at regular intervals. Normally, the navigator determines the fix interval. The interval between fixes depends on the area in which the ship is operating. As the situation changes the navigator may change the fix interval.

For example, if the ship is scheduled to make an rendezvous with another ship in 4 hours, the fix interval may be changed from every hour to every 1/2 hour. The following table gives generally accepted fix intervals for routine situations.

Situation	Obtain a fix every
Open Ocean Navigating, no land within 50 nm.	hour
Open Ocean Navigating, land is within 50 nm, but not closer than 25 nm.	1/2 hour
Coastal Navigating, land is within 25 nm, but not closer than 10 nm.	15 minutes
Coastal Navigating, land is within 10 nm, but not closer than 5 nm.	10 minutes
Restricted Water, piloting	3 minutes

## General Duties of the QMOW, Continued

---

### Using All

### Available Means to Determine Position

It is important to use all methods available to fix the ship's position. The navigator is required by instruction to fix the ship's position by all available means. You as the QMOW must make every effort to accomplish this. In actual situations, you will often use a combination of methods to determine the ship's position. If transiting along a coastline and visual or radar fixes are available, use them! In the following list you'll find methods of fixing the ship's position listed by accuracy, from the most accurate to the least accurate:

- A visual fix on three objects 120° apart
- A visual fix on two objects 90° apart
- An electronic fix by GPS in the encrypted mode
- A visual bearing and radar range on one object
- A radar fix using three range arcs on objects 120° apart
- A radar fix using two range arcs on objects 90° apart
- An electronic fix by the AN/SRN 12 SATNAV
- An electronic fix by LORAN

---

### Approaching Land

When approaching land from the open ocean, the QMOW must start checking to see if radar fixes can be obtained. At about 25 nm, the shoreline will start to become distinct. If sharp points of the shoreline are available, radar fixes should be obtained. Radar fixes are used in addition to whatever means are currently in place. In other words, if fixes were being determined by GPS, you would continue to plot GPS and also plot radar. As the ship progresses toward land, visual fixes would be added. This process continues until the ship enters restricted waters and the navigation detail takes over the watch.

During all of this activity, you must continue to maintain the DR plot. As you learned in chapter 8, the DR plot must never be neglected while you perform other tasks. In obtaining a fix, you are actually updating the DR plot. You'll find that as a ship draws closer to land, changing course often becomes necessary due to shipping traffic. This makes keeping your DR plot up to date even tougher. On the open ocean, the QMOW's ability is not taxed often; however, the watch becomes very busy when approaching land. Always make an effort to be prepared. Make sure that you have the next chart available and that your books and logs are up to date. If at any time, you are unsure of the ship's position, do not hesitate to contact your LPO or assistant navigator for guidance.

## General Duties of the QMOW, Continued

---

### Maintaining Logs

As you now know, maintaining the Ship's Deck Log is a big part of the QMOW's duties. You must also maintain the following records:

- Magnetic Compass Record Book
- Standard Bearing Book
- Weather observation sheets
- Passdown log

The Magnetic Compass Record Book must be filled in each time the ship changes course and on the hour and every 1/2 hour as explained in chapter 2. For example, if a ship changed course at 1947 an entry would be made. The next entry would be 2000 and 2030, and so on until the next course change. Gyrocompass error is entered in the remarks column each time it is computed.

The Standard Bearing Book is used to record bearing, range, and location of ATONs or radar points used to fix the ship's position, during piloting. Remember to enter the latitude and longitude of every ATON or radar point used to fix the ship's position beginning on the inside of the back cover or as directed by the navigator.

As you learned in chapter 10, weather observation must be made each hour whenever a ship is under way. You should begin your observations about 15 minutes before the hour. This allows you to completely record the observation data on the weather observation sheets prior to obtaining the hourly fix of the ship's position.

The passdown log is used to pass pertinent information down from watch to watch. Make sure to record any information passed down to you that concerns any aspect of the watch.

---

### Plotting to support Weapons

During some operations, you may be required to maintain a plot in support of live firing exercises. Maps that use a grid system of coordinates are used to maintain the plot. This type of plotting requires specialized training involving both OSs and QMs and is scheduled by the Operations Department. The OSs maintain the manuals and instruction that give complete information on his topic.



## General Duties of the QMOW, Continued

---

### **Making Reports to the OOD**

After each fix, you are required to make reports of the ship's position to the OOD. When reporting, it is normal to report whether the ship is on track, the distance left or right of track, course and speed the ship is making good, any set and drift encountered, recommended course and speed changes, and estimated time of arrival at the next departure point (A, B, C, and so on) or rendezvous.

As you can see, there is quite a bit of information to report. To gather the required information, you will have to evaluate two or more fixes. This is a simple task that only takes a few minutes with a little practice. Let's break the evaluation down into sections, beginning with where the ship is in relation to track.

As you know, a ship steers a course to follow the track to its destination. The bow is actually always falling off left or right of course and then the helmsman uses the rudders to correct. This is due mainly to wind and current. Rarely does a fix fall exactly on the ship's track. To determine how far off track the ship has gotten, simply use the dividers to measure the distance left or right, 90° to the track, and jot down the results.

To find the course and speed made good since the last fix, use the parallel rulers and compass rose or PMP aligned on the last two fixes to find the course made good (CMG). Measure the distance between the last two fixes to find the speed made good (SMG). Remember from earlier chapters to use the time, speed, and distance triangle. Distance divided by time equals speed. Jot down your results. We now have two elements of our report. The next element to find is set and drift.

**Set and Drift:** What exactly is set and drift? Well, the term *set* means the direction in which the ship is being pushed off course. *Drift* is the speed or velocity that the ship is being pushed off course.

You will need recommended courses and speed changes to offset the effects of set and drift. In some cases, it may be necessary steer several degrees left or right of the desired course to make that course good. Once again, keep in mind that set and drift are directly related to the amount of wind and current. Let's work an example problem to find the value of set and drift.

## General Duties of the QMOW, Continued

**Example:** The ordered course and speed is 080° at 10 knots. You have just plotted the 1000 fix, which shows the ship right of track. What is the set and drift? Refer to the following table and figure 11-8 to find set and drift.

Step	Action
1.	Find the CMG and SMG between the 0900 (A) and 1000 (C) fixes. You can see the CMG = 089 and SMG = 11.2 kn.
2.	Using a parallel ruler or PMP, find the direction between the 1000 DR (B) and the 1000 fix (C). As you can see, this equals 140°, the ship is being set in the direction of 140°
3.	Using dividers, measure the distance between the 1000 DR (B) and the 1000 fix (C). The distance is equal to 2.0 nmi.
4.	To find drift, divide the distance by the time between the two fixes. For our example the time between the two fixes is 1 hour. Drift equal 2.0/1.0 or 2.0 kn.  <b>Note:</b> You may measure set and drift over many hours, if necessary. For example, if distance = 8.4 nmi, time = 7.5 hours what is the drift? $8.4 \div 7.5 = 1.12$ ; drift equals 1.12 knots

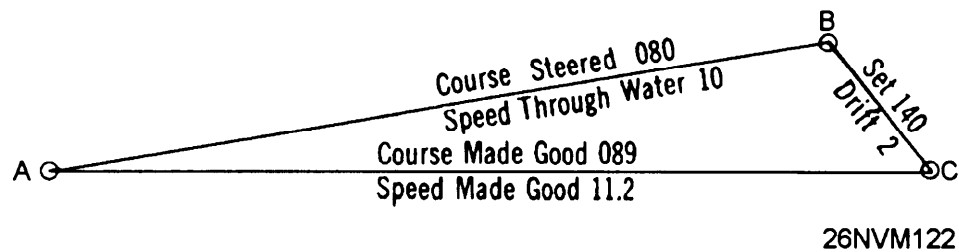

Figure 11-8. Finding set and drift.

## General Duties of the QMOW, Continued

**Allowing for Set and Drift:** Once you have determined set and drift, you can allow for it to make your desired course and speed.

**Example:** Let's assume that you need to make course 265° and speed 15 knots good to arrive at the desired location on time. Set and drift are determined to be 185° at 3 knots. Use the following table and figure 11-9 for this example.

Step	Action
1.	From your latest fix (A), lay out course and speed to make good (B).
2.	From A, lay out a line in the set direction of 185° and the amount of drift of 3 knots (3 nmi), which gives you point C.
3.	Determine the course to steer by finding the direction between C and B. This is equal to 276° in our example
4.	Determine speed necessary to make 15 knots good by dividing the distance between C and B by the time of the run.

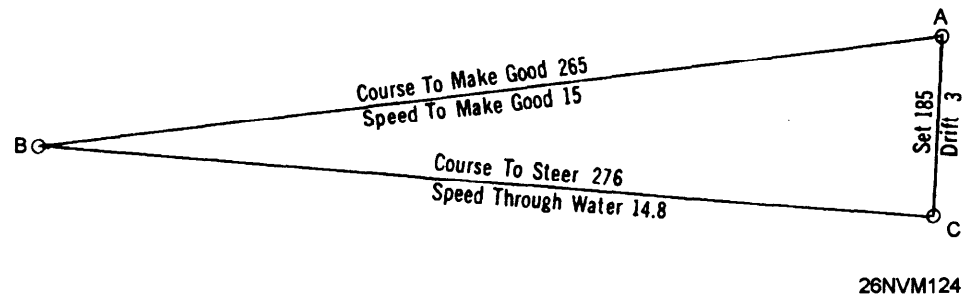

Figure 11-9. Allowing for estimated current.

### Making Recommendations

You now have the knowledge to make recommendations to the OOD. Remember, after each fix you should make a report and any recommended course and speed changes required. Also, when maintaining the DR plot, always check to see that new courses ordered by the conning are clear of obstructions. The OOD will often have to maneuver the ship to avoid other ships.

## General Duties of the QMOW, Continued

---

### Ship's Position Reports

As prescribed by *Naval Regulations*, the navigator must report the ship's position to the commanding officer. These reports, called Ship's Position Reports, are prepared and submitted three times a day; 0800, 1200, and 2000. The report provides the commanding officer with the ship's current position, how it was determined, distance traveled since the last report, distance to the destination, and compass information.

The completed report is submitted to commanding officer about 5 to 10 minutes prior to the appointed hour. As the QMOW, you may be tasked with providing some of the information for the report. Normally you would begin the report about one-half hour prior to the appointed hour and fill in position and compass information only.

---

### Observing Sunrise and Sunset

Another duty of the QMOW under way is to observe sunrise and sunset. The times of sunrise and sunset are normally determined for the entire transit prior to departing port. To observe sunrise, turn off running lights, report to the OOD, and make deck log entry when the Sun appears on the horizon. To observe sunset, energize and check for proper operation of all running lights, report to the OOD, and make deck log entry when the Sun disappears from the horizon.

---

### Rendering Honors

As QMOW, you may be required to render honors to passing honors to U.S. Navy, Coast Guard, or foreign Navy ships. This applies to small boats carrying official parties also. The following table lists the procedure to be used to render honors. Complete information on honors and ceremonies can found in chapter 12 of *Naval Regulations* and BM TRAMANs.

Close aboard equals 600 yards for ships and 400 yards for boats.

Step	Action
1.	When close aboard with the bow of each ship about to pass, the junior vessel sounds the command ATTENTION TO PORT OR STARBOARD.
2.	When abreast, the junior vessel sounds the command HAND SALUTE.
3.	When the senior acknowledges the rendered honors, the junior vessel sounds the command CARRY ON.

## General Duties of the QMOW, Continued

---

### **Reporting Contacts**

While under way, it's the lookout's job to report visual contacts (other ships). Again, remembering that the QMOW is an assistant to the OOD, report any contacts that you observe.

Report a new contact to the OOD by relaying the following information about the vessel:

- Relative bearing
  - Range in yards
  - Type of vessel and class if possible (merchant, naval, DDG, and so on)
- 

### **Making Recomendations Based on Rules of the Road**

The OOD is thoroughly versed in the Rules of the Road; however, you may make recommendations concerning navigational light displays and prescribed sound signals required by the rules.

---

### **Special Evolutions**

The bridge must be set up for all special evolutions. These include evolutions such as, general quarters, UNREP, entering restricted waters, and running a measured mile. As each ship is different, only general discussion will be provided.

In general, the QMOW with the assistance of the QM gang will set about getting the bridge ready for scheduled evolutions. Items like sound-powered phones, phone and distance lines, and light wands must be put in place and tested prior to the beginning of any evolution.

When preparing to run a measured mile, the navigation detail should be set.

## General Duties of the QMOW, Continued

---

### Duties While at Anchor

The rules for relieving the watch at anchor are the same as when under way except that night orders aren't signed. The OOD may be stationed on the bridge or at the quarterdeck. An anchor watch stationed on the forecastle reports how the anchor is tending and the amount of strain on the anchor chain.

Fixes are taken from available objects. A combination of visual and radar fixes are used when suitable lighted aids are unavailable. Fixes are normally taken on the hour and 1/2 hour. However, once again the navigator is responsible for determining the frequency of fixes. On many ships, fixes are taken every 15 minutes when winds of more than 30 knots are present. The anchor watch report is obtained at the time of each fix and reported to the OOD. You are also required to maintain a close watch of any shipping traffic in the area. If any ship anchors within 2,000 yards of your own ship, make a report to the OOD.

If, at any time, the ship plots outside of the drag circle or you suspect the anchor of dragging, immediately inform the OOD. You must begin fixing the ship's position continuously until directed to resume normal fixes by the CDO or navigator.

**Radio Communications:** You may be required to monitor R/T and VHF circuits. You should receive specific directions on which circuits you must guard. Always take appropriate action as required on any messages received over the circuits, and properly maintain the required logs.

---

### QMOW in Port

While in port, your major responsibility is to hold morning and evening colors and turn on and off inport lights. To start the day, you observe sunrise and secure inport lights. At 0745, arrive on the bridge to execute morning colors. At precisely 0755, SOPA will hoist PREP at the Dip, you will announce over the 1 MC "FIRST CALL, FIRST CALL TO COLORS." At 0800 SOPA will close up PREP and sound one whistle blast over the one MC, you will do the same. After the National Anthem is finished playing, SOPA will haul down PREP and sound three whistles and once again you'll do the same. Immediately after evening colors is executed, turn on inport lights. The duty SM is responsible for posting PREP on your ship.

You may be tasked from time to time with gathering weather or navigational data for the CDO.

# Chapter 12

## Voyage Planning

---

### Introduction

In this chapter we will discuss one of the most important aspects of navigation; voyage planning. Every successful voyage starts with a well thought out plan. We will cover all details of developing a plan that will enable you to have a successful voyage.

---

### Objectives

The material in this chapter will enable the student to:

- Plan and construct great-circle tracks.
  - Plan and construct coastal tracks.
  - Plan and construct restricted water tracks.
  - Plan and construct precision anchorages.
  - Plan for deployments.
  - Plan and construct navigation briefs.
  - Prepare to enter or depart port.
- 

<b>Topics</b>	<b>Page</b>
Planning and Constructing Great-Circle Tracks	12-2
Planning and Constructing Coastal Tracks	12-6
Planning and Constructing Restricted Water Tracks	12-7
Constructing Turn Bearings	12-8
Constructing Danger Bearings	12-10
Precision Anchoring	12-13
Navigation Brief	12-21
Departing Port	12-22
Entering Port	12-25

# Planning and Constructing Great-Circle Tracks

---

**Considerations** The navigator (NAV) and assistant navigator (ANAV) must lay out the ship's complete intended track on the proper chart format. This task is undertaken after the planning stage is complete but several days or weeks before getting under way, depending on the length of cruise.

If your track will be less than 300 nautical miles, a small-scale Mercator chart will be adequate. However, for those tracks exceeding 300 nautical miles, you will probably use the gnomonic or great-circle chart. There may be some cruises longer than 300 nautical miles where a Mercator or other type of chart is more appropriate than the great-circle chart.

You will recall from chapter 1 the shortest distance between two points is a straight line. A straight line is perfect for navigational track planning using a great-circle chart (gnomonic projection).

The Defense Mapping Agency (DMA) publishes a number of charts, at various scales, using the gnomonic projection and covering the usually navigated portions of Earth. These are listed in the DMA *Catalog of Maps, Charts, and Related Products*, part 2, volume X. The point of tangency is chosen for each chart to give the least distortion for the area to be covered. On this type of chart, a great circle appears as a straight line. Because of this property, the chart is useful in great-circle sailing.

The following table shows the different stages of constructing a great-circle track:

Stage	Description
1.	Select a great-circle chart that has a point of tangency nearest your ship's predicted track.
2.	Draw the track and check for dangers (consult sailing directions).
3.	Transfer to open ocean Mercator charts (plotting sheets).
4.	Label all departure points.
5.	Determine SOA and lay out PIM.



## Planning and Constructing Great-Circle Tracks, Continued

### Track Construction

Use the following step action table to construct a great-circle track:

Step	Action
1.	Plot the departure and arrival points on the gnomonic chart projection.
2.	Draw a line between the two points (see fig. 12-1).
3.	Inspect the track to make sure that it does not cross any dangers. Redraw if necessary.  <b>Note:</b> If the track must be redrawn, always do so on the gnomonic chart. This will have less impact on overall mileage than navigating around dangers on a Mercator chart.
4.	Select convenient points to use to transfer the track to small scale Mercator charts. Normally these points should be about 300 nmi apart; refer again to figure 12-1.
5.	Label the points beginning with the letter A.
6.	Extract and record the latitude and longitude of each point. This information can be used later for the movement report (MOVREP).
7.	Transfer the points to small scale Mercator charts (fig. 12-2) to show the entire transit.  Transfer the points to larger scale Mercator charts that cover about one leg of the transit each.  <b>Example:</b> Transfer points A and B on the first Mercator chart selected; transfer points B and C on the second Mercator chart selected; and so on.
8.	Label the track with course and distance for that leg.
9.	Go to steps 7 and 8 until all legs of the track have been transferred and labeled.  Now the last stage is to lay out PIM. Move on to page 5.

# Planning and Constructing Great-Circle Tracks, Continued

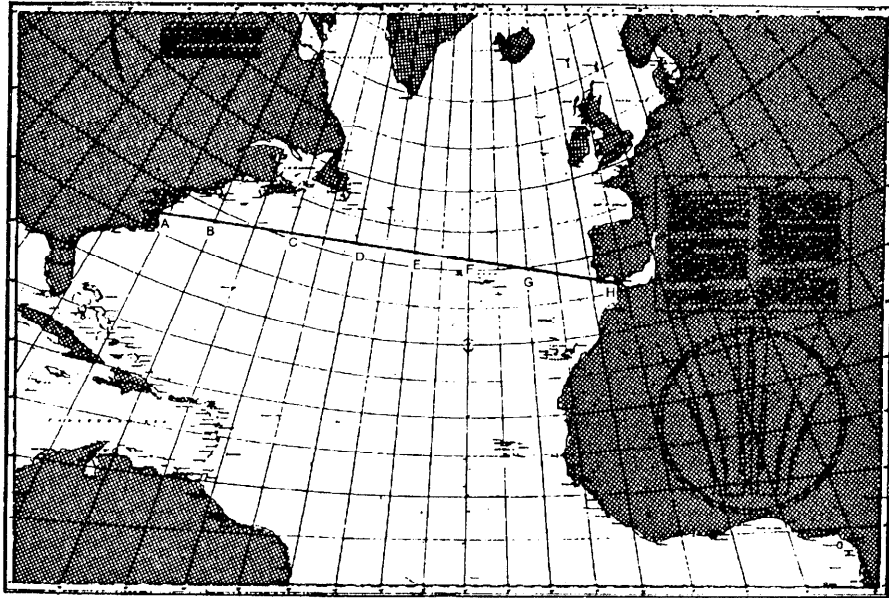

Figure 12-1. Great-circle route; Norfolk to Gibraltar.

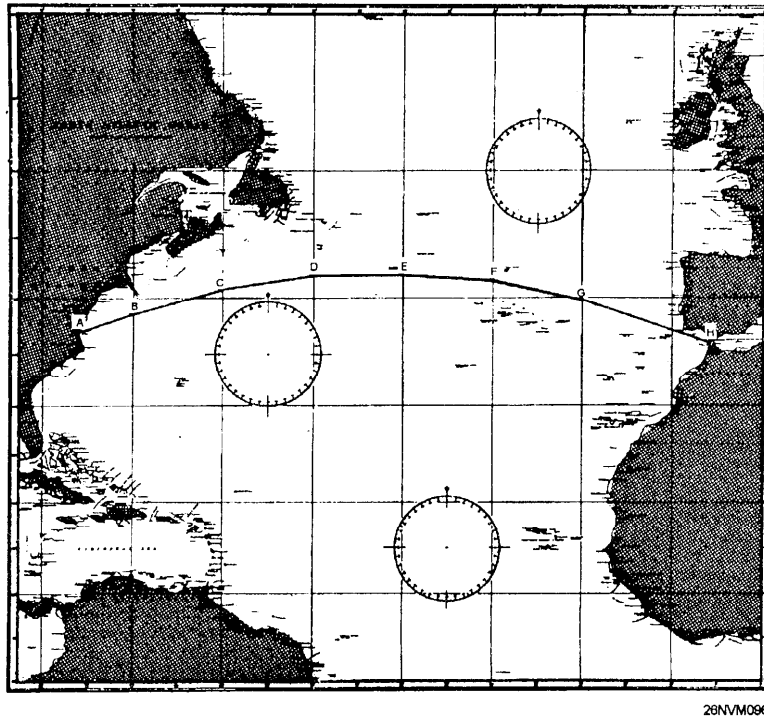

Figure 12-2. Rhumb line approximation to the great-circle track.

# Planning and Constructing Great-Circle Tracks, Continued

## PIM

At this point in track construction, we have done everything except determine PIM. Use the following step action table to determine PIM and label the track. As an example, we will assume that the ship departs at 10SEP1200Z and arrives at the straits of Gibraltar on 19SEP0700Z.

Step	Action
1.	Find the total hours available for the transit. $19\ 0700 = 18\ 3100$ $\underline{10\ 1200}\quad \underline{10\ 1200}$ $8\ 1900 = 8\ \text{days} \times 24\text{h} + 19\text{h}$ or 211 hours
2.	Add together all rhumb line distances between points A through H. For our example, we'll assume this to be 2247.5 nmi.
3.	Determine the overall SOA. $2247.5\ \text{nmi} \div 211\ \text{hours} = 10.65\text{kn}$ . Always round up to the nearest 1/10 of a knot. SOA = 10.7
4.	Begin with the departure point and lay out PIM times and date in GMT for every 4 hours of transit time. Also label the time of departure from each individual point. At this point we have completed our track construction. As an aid to tracking the ship's progress it is highly recommended that the track also be transferred to a small scale chart, as shown in figure 12-3.

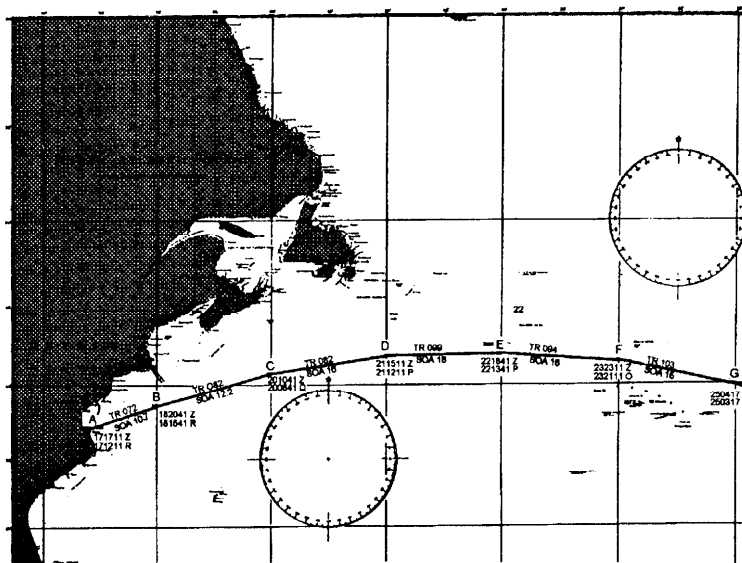

26NVM087

Figure 12-3. Segment of overall track.

# Planning and Constructing Coastal Tracks

---

## Considerations

There is a great difference between planning coastal tracks and great-circle tracks. Coastal tracks often require more attention to dangers and shoals. Normally coastal navigation may be defined as any ship operating within 50 nmi of a coastline. Often there are many shoals or dangers which must be avoided. Let's look at a real world example.

Ships departing Norfolk for southern OPAREAs often depart the traffic separation scheme of Chesapeake Bay and steer on a SE heading. Careful attention must be paid to this route due to shallow water and submerged obstructions up to about 25 nmi from the coast in many places. Also, hazards to navigation when turning south around Cape Hatteras are too numerous to mention.

The point of this discussion is to make clear the dangers of coastal navigation. The following rules apply to coastal track construction.

### **Rules:**

- Always review all applicable coast pilots and sailing directions before laying down tracks
- Check the proposed track thoroughly for dangers. Never allow the track to pass within 5 nmi of any danger.
- Highlight all coastal aids to navigation
- Highlight any shoals, towers, OADS buoys, or other obstructions.
- Use the best scale of chart available for any area the ship transits.

Use the following table to construct coastal tracks:

<b>Step</b>	<b>Action</b>
1.	Choose points from a small scale mercator chart that covers the entire area the ship will transit. Draw lines for tracks and label.
2.	Transfer track to the best scale coastal charts available.
3.	Check each leg of the transit for dangers.
4.	Determine SOA and label each chart with PIM.
5.	Apply all rules making sure to highlight shoal water, dangers, and NAVAIDs.

# Planning and Constructing Restricted Water Tracks

---

## Gathering Information

The most critical track the QM will construct is the restricted water track. This is because the ship is at its most vulnerable time when transiting dangerous channels. You must plan for all contingencies. It seems that Murphy's law applies most often when a ship is in a channel.

**Chart selection:** Professional and thorough chart selection and preparation is the foundation on which safe piloting through restricted water tracks is based.

Effective chart selection requires a combination of skill and judgment. Here are some questions to consider when selecting charts for restricted water tracks.

Has the best scale chart been selected for the given area?

Have conspicuous NAVAIDs been lost due to choosing the largest scale chart available?

Are the latest editions of selected charts available?

**Research:** During the research phase, all reference material on the port should be consulted and notes made. Often port directories and fleet guides will provide invaluable data concerning entering or departing a given port. Often information concerning best approaches, traffic separation schemes, tidal currents, berths available, channel depths, and so on are listed.

Taking detailed notes on this information will speed the process of constructing the restricted water tracks. Once you have gathered information about the port and selected the charts to use, you can start the actual laying down of tracks.

Before you can lay down the actual tracks, you'll have to learn about red and yellow soundings, turn bearings, highlighting dangers, and danger bearings and angles.

# Planning and Constructing Restricted Water Tracks, Continued

---

**Red and Yellow Soundings** Red soundings are defined as the minimum depth beneath the keel that the CO deems acceptable. For example, the CO may desire that the ship's draft + 3 feet equal the value for red soundings. For a ship with a draft of 30', the red sounding would equal 33'. This means that at no time may the ship enter water with a depth of less than 33'

Yellow soundings are defined as the depth beneath the keel that indicates potential danger. This depth is also determined by the CO. It may be the ship's draft + 6 feet.

Red and yellow soundings are marked on the chart using a fine felt tip marker of the correct color (red or yellow). After studying the charted depths, freehand draw the red and yellow soundings limits. The result will yield a red or yellow line similar to a fathom curve.

---

**Highlighting NAVAIDS** All prominent NAVAIDS must be highlighted in yellow. This includes any radar navigation points that are selected for use. Radar points should be labeled beginning with the letter A in the direction of travel.

---

**Turn Bearings and Ranges** Turn bearings and ranges indicate the instant at which the rudder is put over to execute a left or right turn. Turn bearings and ranges are created by using the advance and transfer quantities (see fig. 12-4) of your ship's handling characteristics to plot a point on your track to which a bearing line or range arc is laid to a prominent NAVAID. A lighted NAVAID is best for day and night versatility for bearing lines only. The NAVAID should be as nearly perpendicular to the ship's track as possible. In narrow channels or tight turns the ship's transfer quantity must be closely considered when laying the turn bearing or range arc. See figure 12-5.

**Turn ranges** present a few differences from turn bearings. The turn range is an arc segment and should be identified' on the primary chart by a unique color or plotted only on the CIC secondary plot chart. If the use of turn ranges is necessary, for example, fog restricted visibility, the navigator will normally shift his or her station to the CIC secondary plot.

The *slide bar technique* is accomplished by paralleling the next intended course to the ship's actual course. By doing this, the turn bearing can be easily revised as shown in figure 12-5.

# Planning and Constructing Restricted Water Tracks, continued

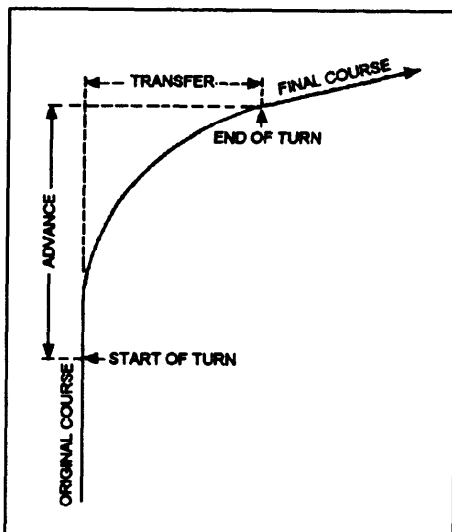

26NVM102

Figure 12-4. Advance and transfer.

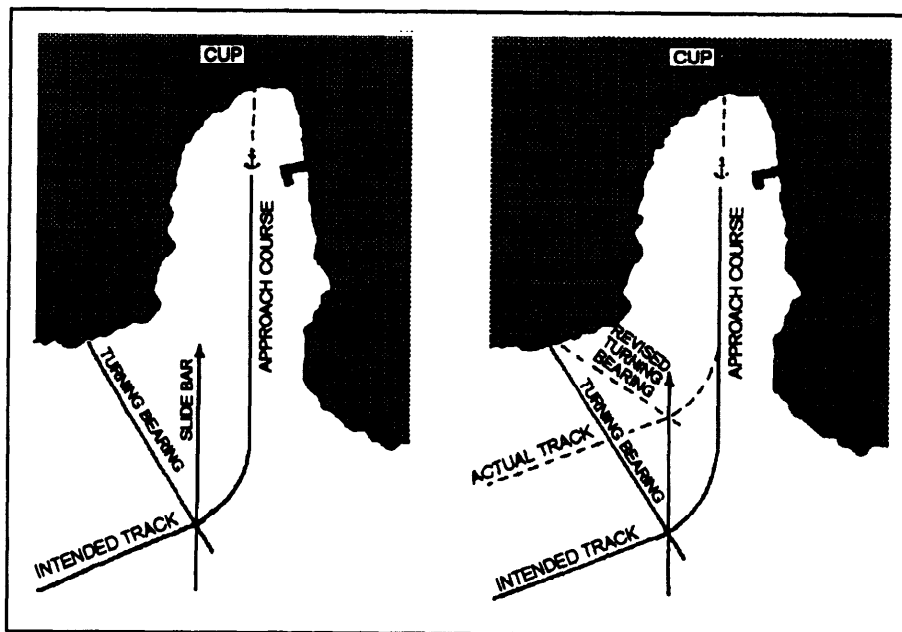

26NVM103

Figure 12-5. Turn bearings and slide bar technique.

## Planning and Constructing Restricted Water Tracks, Continued

**Danger Bearings** A danger bearing is used by the navigator to keep the ship clear of an outlying area of danger close to where the ship must pass. In all probability, a danger area has been previously surveyed and is plotted on the chart, but, in the vast majority of cases, it will give no warning of its presence to the eye. Examples of such dangers are submerged rocks, reefs, wrecks, and shoals. A danger bearing must be established between two fixed objects, one of which is the danger area. The other object must be selected to satisfy the following conditions: (1) It must be visible to the eye; (2) it must be indicated on the chart; and (3) true bearing from the danger area should be in the same general direction as the course of the ship as it proceeds past the danger.

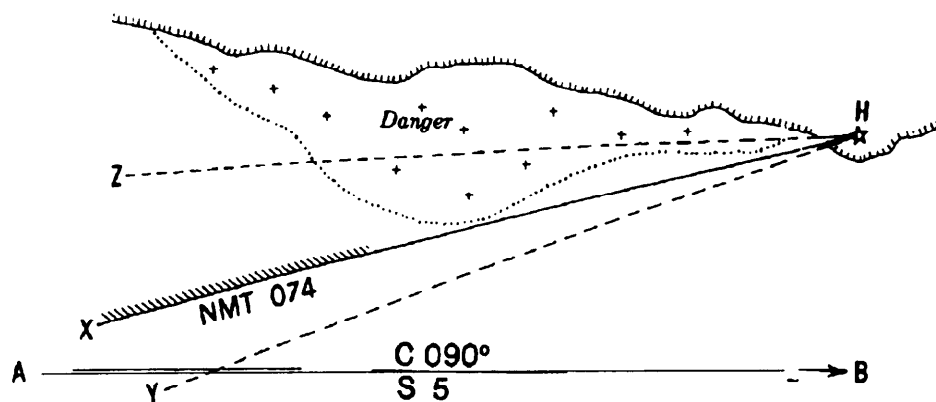

Figure 12-6. Example of a danger bearing.

As shown in figure 12-6, a ship is proceeding along a coast on an intended track of  $090^{\circ}\text{T}$  at a speed of 5 knots (line AB). A shoal on the port side is to be avoided. A line is drawn from lighthouse H, tangent to the outer edge of the danger (line HX). As long as the bearing of lighthouse H is *less* than line XH (the danger bearing), the ship is in safe water. The danger bearing in this illustration is  $074^{\circ}\text{T}$ . You will notice that the danger side of the danger bearing is hatched. The danger bearing is also labeled with NMT (meaning NOT MORE THAN). An example of a bearing to lighthouse H that would indicate that the ship is in safe water is the broken line YH. No part of this bearing line passes through the danger area. Any bearing *greater* than the danger bearing (line XH), such as the broken line ZH, indicates a possible dangerous situation. If the danger area is being passed on the port side, as in this illustration, the safe bearing is less than the danger bearing. Danger angles are not normally used; however, you should use Pub 9, *Bowditch*, to learn more about using them.



## Planning and Constructing Restricted Water Tracks, Continued

**Constructing the Restricted Water Track** In the following table, you'll find all of the steps listed to construct the restricted water track. This list assumes that all information has been obtained about the port.

Step	Action
1.	Mark all red and yellow soundings.
2.	<p>Lay down intended tracks. Normally, the intended track is laid down in the middle of the channel (see fig. 12-7). The only exceptions are very wide channels with mid-channel buoys where the track is laid in the center of one-half of the channel.</p> <p>Turn points are normally established by the intersection of two course lines that have been laid for different legs of the track.</p>
3.	Label all courses, speeds, and distances.
4.	Check for hidden dangers; construct danger bearings if necessary.
5.	Create turn bearings for each turn. Remember to use lighted NAVAIDs where possible.
6.	Highlight all NAVAIDs and radar points; record in the Standard Bearing Book.
7.	<p>On several areas of the overall track, display forecasted wind and current data. This may done by drawing arrows that point in the direction of wind or current with the force labeled. Alternately, you may cut out arrows labeled with the information and then use tape to stick the arrows to the chart.</p> <p><b>Note:</b> On larger deep draft vessels, 1 knot of current can equal about the same as 10 knots of wind. Strong winds along with 1 knot or more of current may make larger vessels crab up a channel.</p>

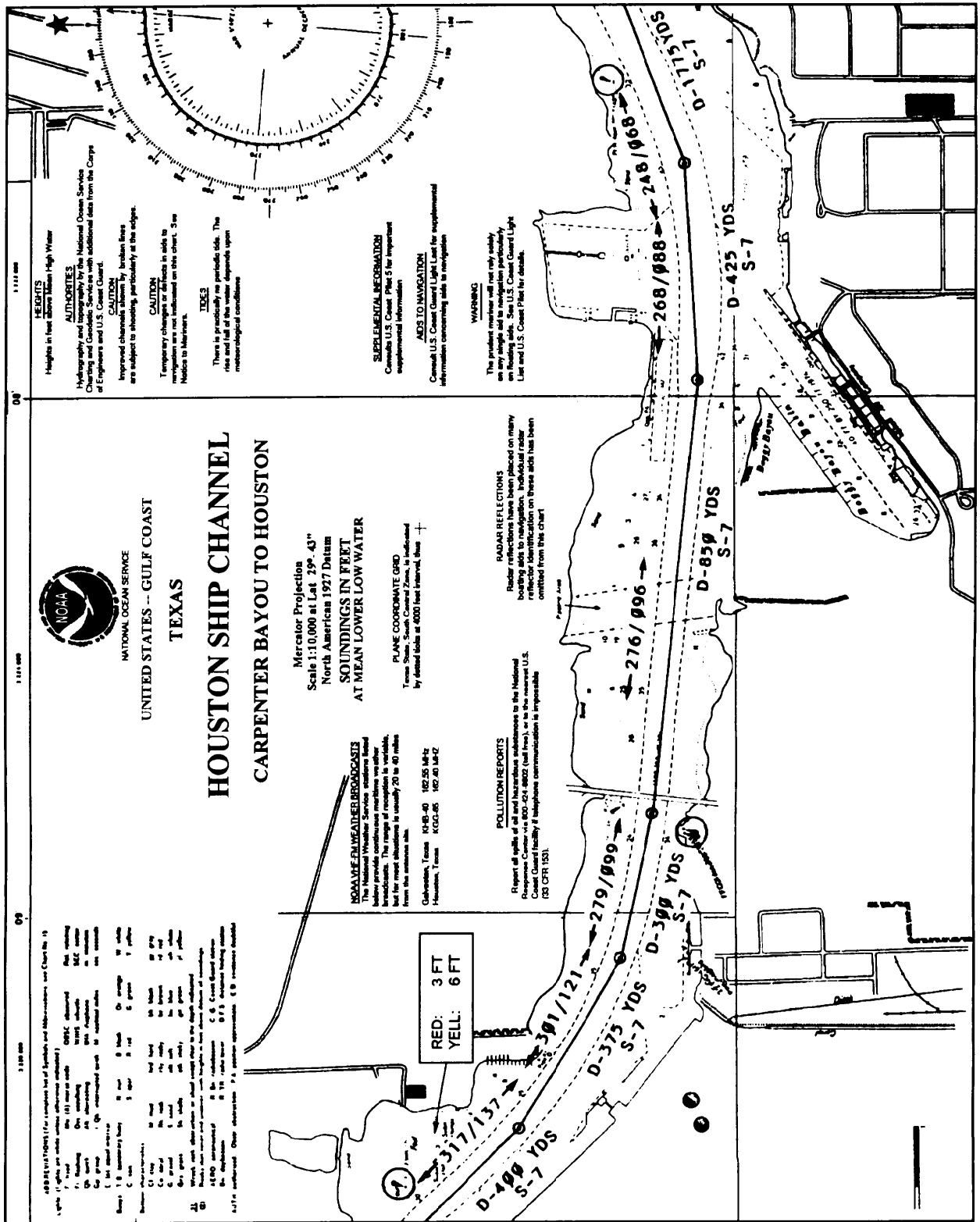

Figure 12-7. Example restricted water track.

# Precision Anchoring

---

## Selecting an Anchorage

An anchorage position in most cases is specified by higher authority. Anchorages for most ports are assigned by the local port authority in response to individual or joint requests for docking or visit. Naval ships submit a port visit (PVST) request letter or logistic requirement (LOGREQ) message well in advance of the ship's scheduled arrival date. Operational anchorages in areas outside the jurisdiction of an established port authority are normally assigned by the senior officer present afloat (SOPA) for ships under his or her command.

If a ship is steaming independently and is required to anchor in other than an established port, the selection of an anchorage is usually made by the navigator and then approved by the commanding officer. In all cases, however, regardless of whether the anchorage is selected by higher authority or by the navigator, the following conditions should always apply insofar as possible:

- The anchorage should be at a position sheltered from the effects of strong winds and current.
- The bottom should be good holding ground, such as mud or sand rather than rocks or reefs.
- The water depth should be neither too shallow, hazarding the ship, nor too deep, facilitating the dragging of the anchor.
- The position should be free from such hazards to the anchor cable as fish traps, buoys, and submarine cables.
- The position should be free from such hazards as shoals and sandbars.
- There should be a suitable number of landmarks, daymarks, and lighted NAVAIDs available for fixing the ship's position both by day and by night.
- If boat runs to shore are to be made, the anchorage chosen should be in close proximity to the intended landing.

## Precision Anchoring, Continued

---

### Selecting an Anchorage

Even when an anchorage has been specified by higher authority, the commanding officer is ultimately responsible for the safety of the ship. The commanding officer has the choice of refusing to anchor at the location assigned if he or she judges it to be unsafe. In these circumstances, the commanding officer should request an alternate location less exposed to hazards.

Many of the coastal charts of the United States and its possessions drawn up by the National Ocean Survey contain colored anchorage circles and anchor symbols of various sizes for different types of ships.

The circles are located on the chart in those areas best suited for anchoring, taking into account the factors listed above. These circles and symbols are lettered and numbered, allowing a particular berth to be specified. Foreign charts often have anchorage areas specified as well. Amplifying information on possible anchorage sites can be obtained from the applicable volume of the *Coast Pilots*, for U.S. waters; from the proper volume of the *En-Route Sailing Directions*, for foreign waters; and from the *Fleet Guide*, for ports in foreign or domestic waters frequented by U.S. Navy ships.

When it is desired to anchor at a location other than that shown as an anchorage berth on a chart, the anchorage is normally specified by giving the range and bearing to it from a charted reference point, along with the radius of the berth.

## Precision Anchoring, Continued

**Terms  
Associated With  
Anchoring**

After the anchorage position has been determined, the navigator is ready to begin plotting the anchorage. In so doing, reference is often made to the following terms:

Term	Definition
Approach track	This is the track along which the ship must proceed in order to arrive at the center of the anchorage. Its length will vary from 2,000 yards or more for a large ship to 1,000 yards for a ship the size of a Navy destroyer or smaller. Under most circumstances, it should never be shorter than 1,000 yards.
Head bearing	If at all possible, the navigator selects an approach track such that a charted NAVAID will lie directly on the approach track if it were extended up to the aid selected. The bearing to the aid thus described is termed the head bearing; it should remain constant if the ship is on track during the approach.
Letting-go circle	This is a circle drawn around the intended position of the anchor at the center of the berth, with a radius equal to the horizontal distance from the hawsepipe to the pelorus.
Letting-go bearing	Sometimes referred to as the drop bearing, this is a predetermined bearing drawn from the intersection of the letting-go circle with the approach track to a convenient landmark or NAVAID, generally selected near the beam.
Range circles	These are preplotted semicircles of varying radii centered on the center of the anchorage, drawn so that the areas are centered on the approach track. Each is labeled with the distance from that arc to the letting-go circle.
Swing circle	This is a circle centered at the position of the anchor, with a radius equal to the sum of the ship's length plus the length of chain let out.
Drag circle	<p>This is a circle centered at the final calculated position of the anchor, with a radius equal to the sum of the hawsepipe to pelorus distance and the final length of chain let out. All subsequent fixes should fall within the limits of the drag circle.</p> <p><b>Note:</b> The actual radii of both the swing and drag circles will in reality be less than the values used by the navigator in plotting them on the chart, because the catenary of the chain from the hawsepipe to the bottom is disregarded. Thus, a built-in safety factor is always included in the navigator's plot.</p>

## Precision Anchoring, Continued

### Before Constructing the Anchorage

Before constructing the anchorage plot, it is always wise to draw a swing circle of estimated radius around the designated anchorage site to check whether any charted hazards will be in close proximity to the ship at any time as it swings about its anchor. If any such known hazards are located either within or near the swing circle, an alternate anchorage should be requested.

If the anchorage appears safe, the navigator begins the anchorage plot by selecting the approach track. During this process, due regard must always be given to the direction of the predicted wind and current expected in the vicinity of the anchorage. Insofar as possible, the approach should always be made directly into whichever of these two forces is predicted to be strongest at the approximate time at which the anchorage is to be made.

Use the following table to construct an anchorage:

Step	Action
1.	<p>Select the approach track by considering the different objects available for a head bearing, taking into account the expected winds and current in the bay. Assuming negligible current and a northerly wind, the tower in figure 12-8 is a good choice for a head bearing.</p> <div data-bbox="584 1208 1252 1661" data-label="Figure"> </div> <p style="text-align: right;">28NVM105</p>

Figure 12-8. W-5 anchorage assignment.



## Precision Anchoring, Continued

---

### **Executing the Anchorage**

When executing the actual anchorage, the navigator's dual objective is to keep the ship as near as possible on its preplanned approach track and to have all headway off the ship when the hawsepipe is directly over the center of the anchorage. As mentioned above, the navigator obtains frequent fixes as the ship proceeds along its track, and keeps the bridge continually informed as to the position of the ship in relation to the track and the letting-go circle. The navigator recommends courses to get back onto track if necessary. Since every ship has its own handling characteristics, speeds that should be ordered as the ship proceeds along the track are difficult to specify. In general, however, with 1,000 yards to go, most ships usually slow to a speed of 5 to 7 knots. Depending on wind and current, engines should be stopped when about 300 yards from the letting-go circle, and the anchor detail should be instructed to "stand by." As the vessel draws near the drop circle, engines are normally reversed so as to have all remaining headway off the ship as it passes over the letting-go circle. When the pelorus is exactly at the letting-go bearing, the word "Let go the anchor" is passed to the anchor detail, and the anchor is dropped.

As the anchor is let go, the navigator should immediately call for a round of bearings to be taken, and he or she should record the ship's head. After the resulting fix is plotted, a line is extended from it in the direction of the ship's head, and the hawsepipe to pelorus distance is laid off along the line, thus plotting the position of the anchor at the moment that it was let go. If all has gone well, the anchor should have been placed within 50 yards of the center of the anchorage.

---

### **Post Anchoring Procedure**

After the anchor has been let go, the chain is let out or "veered" until a length or "scope" of chain 5 to 7 times the depth of water is reached. At this point, the chain is secured and the engines are backed, causing the flukes of the anchor to dig into the bottom, thereby "setting" the anchor.

When the navigator receives the word that the chain has been let out to its full precomputed length and that the anchor appears to be holding round of bearings and the ship's head, as well as the direction in which the chain is tending. With this information, the navigator plots another fix and recomputes the position of the anchor by laying off the sum of the hawsepipe to pelorus distance plus the scope of chain in the direction in which the chain is tending. This second calculation of the position of the anchor is necessary because it may have been dragged some distance from its initial position during the process of setting the anchor.



# Precision Anchoring, Continued

## Post Anchoring Procedure, continued

After the final position of the anchor has been determined, the navigator then draws a second swing circle. This time the navigator uses the computed position of the anchor as the center, and the sum of the ship's length plus the actual scope of chain let out as the radius. If any previously undetermined obstruction, such as a fishnet buoy or the swing circle of another ship anchored nearby, is found to lie within this circle, the ship may have to weigh anchor and move away from the hazard. If the ship is anchored in a designated anchorage area, due care should be taken to avoid fouling the area of any adjacent berths, even though they might presently be unoccupied. If the swing circle intersects another berth, it may be necessary to take in some chain to decrease the swing radius; if this is not possible, a move to a larger berth may be advisable.

If the navigator is satisfied that no danger lies within the swing circle, he or she then draws the drag circle concentric with the swing circle, using as a radius the sum of the hawsepipe to pelorus distance plus the scope of chain. All fixes subsequently obtained should fall within the drag circle; if they do not, the anchor should be considered to be dragging. Both the swing circle and the drag circle are shown in figure 12-10, assuming that a scope of chain of 50 fathoms to the hawsepipe has been let out.

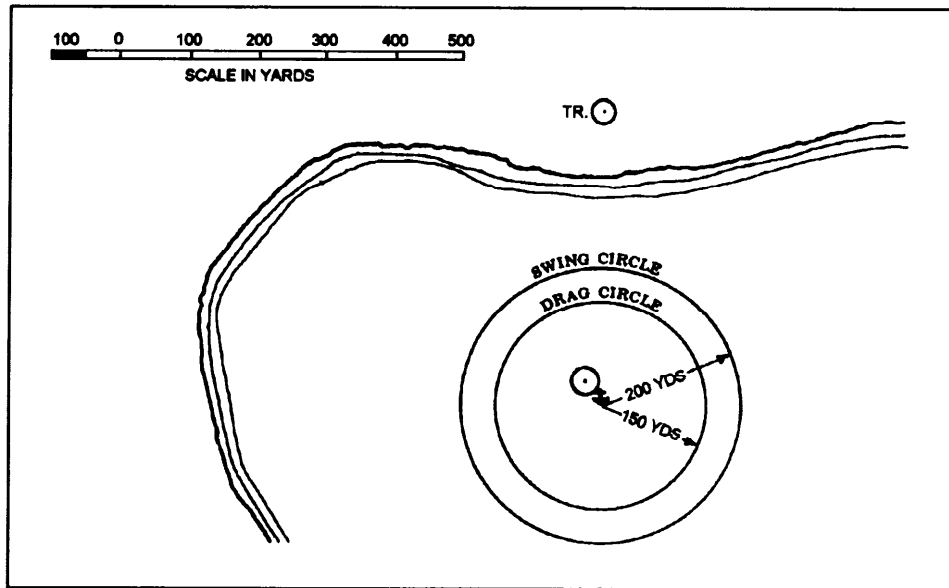

26NVM108

Figure 12-10. Swing and drag circles.

## Precision Anchoring, Continued

---

### Post Anchoring Procedure, continued

After plotting the drag circle, the navigator then selects several lighted NAVAIDs suitable for use in obtaining fixes by day or night and enters them in the bearing book for use by the anchor-bearing watch. The anchor-bearing watch is charged with obtaining and recording in the bearing book a round of bearings to the objects designated by the navigator at least once every 15 minutes, and plotting the resulting fix on the chart each time. Should any fix fall outside the drag circle, another round of bearings is immediately obtained. If the second fix also plots outside of the drag circle, the ship is considered to be dragging anchor and all essential personnel are notified. In practice, if the ship is to be anchored for any length of time, the navigator will usually have the anchor watch cover the area of the chart containing the drag circle with a sheet of semiclear plastic. This is done so the chart will not be damaged by the repeated plotting and erasures of fixes within the drag circle.

When a ship is dragging anchor, especially in high wind conditions, there is often no unusual sensation of ship's motion or other readily apparent indication of the fact. The safety of the ship depends on the ability of the anchor watch to accurately plot frequent fixes and to alert all concerned if they begin to fall outside the drag circle. If conditions warrant, the ship may have to get under way. As interim measures to be taken while the ship is preparing to do this, more chain may be veered to increase the total weight and catenary of chain in the water, and a second anchor may be dropped if the ship is so equipped.

Situations in which high winds are forecast, the ship should assume an increased degree of readiness, with a qualified conning officer stationed on the bridge, and a skeleton engineering watch standing by to engage the engines if necessary. As an example, during a Caribbean cruise a U.S. Navy submarine was anchored off St. Thomas, V.I., in calm waters with less than 5 knots of wind blowing. Because high winds had been forecast for later in the night, the OOD was stationed on the bridge, and a skeleton engineering watch was charged with keeping the engines in a 5-minute standby condition. Two hours after anchoring, after the liberty sections had gone ashore, the wind began to increase. In the next 45 minutes, wind force increased to the point where 55-knot gusts were being recorded. The ship got under way and steamed throughout the night until the storm abated the next day. For additional information on anchoring, types of anchors, and anchoring gear, refer to *Naval Ships' Technical Manual*, chapter 581, titled "Anchors and Anchoring."

# The Navigation Brief

---

## Purpose

The purpose of the navigation brief is to provide a standard procedure that all ships follow prior to getting under way or entering port. The briefing is presented by the navigator to the commanding officer and all key personnel and provides a forum for discussion of the anticipated ship movement. The joint Commander Naval Surface Forces Atlantic and Pacific Instruction 3530.2, *Navigation Standards and Procedures*, provides specific guidance on the minimum requirements of the contents of the navigation briefing.

---

## Content

The following table lists items that may be found on the navigation brief and is meant for illustrative purposes only. Do not rely solely on this table but rather the joint instruction 3530.2 when constructing a navigation briefing.

Item	Description
Watch Assignments	All key individuals are identified by name; for example, the OOD, JOOD, EOOW, CICWO, and helm safety officer.
Charts	All charts and tracks are reviewed. Information briefed includes items such as course and speed of each leg, all dangers and hazards, NAVAIDs, port requirements, demarcation lines, emergency anchorages, and turn bearings.
Engineering	The status of the engineering plant is reported.
Navigation Equipment	The status of all navigation equipment is reported.
Environmental Conditions	Tide and current data is briefed for each leg of the transit. Forecasted weather is briefed.
Pilot and Tugs	Pilot pickup or drop off is briefed along with the number of tugs anticipated.

---

## Construction

The actual construction of the navigation brief varies from ship to ship. Some ships use preapproved forms while others use word processors or data bases to construct a navigation brief. For either case the senior Quartermaster and the navigator usually gather all required information for the navigation briefing.

# Preparing to Depart Port

## Standard Checklist

Use the following standard checklist to prepare to depart port. The items listed may be modified as necessary by individual ships.

Time prior	Action
48 hours	Establish getting under way schedule to cover propulsion plant light off, shift from shore to ship's power, last boat run, rigging in of accommodation ladder, disposal of ship's vehicles, light off and testing of electronics suite, and U.S. and guard mail.  Release MOVEREP.
24 hours	Conduct navigation brief.  Verify arrangements for tugs/pilot.  Compare bridge and CIC charts.  Conduct steering system PMS.  Verify schedule for lighting off power plant.  Check navigation lights for proper operation.  Verify arrangements for running the degaussing range.  Ascertain scheduled ship movements.
8 hours	Energize gyrocompass.  Energize and calibrate all radar repeaters.  Energize and initialize all electronic navigation equipment.
4 hours	Determine gyro error.  Confirm tugs/pilot/line handlers.
3 hours	Verify arrangements for discontinuance of shore services.

## Preparing to Depart Port, Continued

Time prior	Action
2 hours	<p>Find out from the XO:</p> <ol style="list-style-type: none"> <li>1. If any variation in standard sequence of stationing special sea and anchor detail exists.</li> <li>2. Time of heaving in to short stay or singling up lines.</li> <li>3. Disposition of boats and vehicles.</li> <li>4. Instructions concerning U.S. and guard mail.</li> <li>5. Number of passengers and expected time of arrival.</li> </ol> <p>After obtaining permission from the executive officer, start hoisting boats and vehicles as soon as no longer required.</p> <p>After obtaining permission from the executive officer, rig in booms and accommodation ladders not in use and secure for sea.</p> <p>Promulgate under way time to all hands.</p> <p>Energize all radars except those prohibited by local electromagnetic emission restrictions.</p> <p>Conduct radio checks on all required circuits. (Include bridge-to-bridge RT.)</p>
1 1/2 hours	<p>Muster the crew.</p> <p>Shift into the uniform of the day, if applicable.</p>
1 hour	<p>Set condition YOKE.</p> <p>Clear ship of visitors.</p> <p>MAA inspect for stowaways.</p> <p>Tune and peak radars.</p> <p>Ensure cleanliness of pier.</p> <p>Ensure that the pit sword is in raised position, if applicable.</p>

## Preparing to Depart Port, Continued

Time prior	Action
45 min	<p>Station the special sea and anchor detail.</p> <p>In reduced visibility: (1) station the low visibility detail; and (2) set material condition ZEBRA on the main deck and below.</p> <p>Make reports to DCC.            Embark pilot. Display CODE HOTEL.            Prepare anchor for letting go.            Test anchor windlass.            OOD shift watch to the bridge.            Conduct loss of steering drill.            Test sound-powered phone circuits in use.            Post tide/current/NAVAID information on the bridge and CIC.            Receive departmental reports for readiness to get under way.            MAA make report of inspection for stowaways.            Record draft of ship fore and aft in ship's deck log, if applicable.            Raise deck edge antennas, if required.</p>
15 min	<p>Obtain commanding officer's permission to test main engine(s) and direct engineering control accordingly after ensuring that the screw(s) is/are clear.</p> <p>Test ship's whistle and general alarms.</p> <p>If alongside a pier, ensure that all shore connections are broken and that the brows are ready to be removed.</p> <p>Single up lines when so ordered.</p> <p>Conduct time check throughout the ship.</p> <p>Report when ready for getting under way to the executive officer.</p>
10 min	<p>Order maneuvering bells by setting the engine revolution indicator system on a certain repetitive number combination beyond the range of the engines, such as "999", if applicable.</p> <p>Warn engineering control to stand by to answer all bells.</p> <p>If a flag officer or unit commander is embarked, request permission to get under way as scheduled.</p>
ZERO	Under way.
After U/W	<p>Shift colors/close up international call sign.            When clear of restricted waters, lower pit sword.            When clear of restricted waters, conduct loss of steering drill.            Advise CO when entering international waters and haul down international call sign.</p>

# Preparing to Enter Port or Restricted Waters

## Standard Checklist

Use the following standard checklist to prepare to enter port or restricted waters. The items listed may be modified as necessary by individual ships.

Time prior	Action
24 hours	Conduct navigation plan brief. Ensure CIC and bridge chart tracks are the same.
When Directed	Dump all trash and garbage overboard. Pump bilges when conditions permit. Blow tubes if required. Raise the pit log. Ensure the smart appearance of the ship.
3 hours	Ascertain the expected time of anchoring or mooring from the navigator, and notify the engineer officer, weapons officer, first lieutenant, and EOOW.
1 hour	<p>Pass the word, MAKE ALL PREPARATIONS FOR ENTERING PORT. THE SHIP WILL ANCHOR (MOOR ____ SIDE TO) AT ABOUT _____. ALL HANDS SHIFT INTO THE UNIFORM OF THE DAY.</p> <p>Weather permitting, remove such canvas covers as are normally off when in port.</p> <p>Obtain information concerning boating from the XO; inform the first lieutenant. Lay out mooring lines if required. Set up and check all harbor and tug frequencies.</p> <p>Test ship's whistle and general alarms. Station the navigation detail. Conduct time check throughout the ship.</p>
45 min	<p>Pass the word GO TO YOUR STATIONS, ALL THE SPECIAL SEA AND ANCHOR DETAIL. Have anchor ready for use when appropriate. Determine and record fore and aft draft of the ship.</p> <p>Prior to approaching restricted waters, conduct a loss of steering drill.</p> <p>Hoist international call sign when entering inland waters.</p>

## Preparing to Enter Port or Restricted Waters, Continued

Time prior	Action
30 min	<p>Obtain information from navigator on depth of water at anchorage, anchor and scope to be used, and inform first lieutenant.</p> <p>Receive readiness reports for entering port.</p> <p>Request permission to enter port from the proper authority.</p> <p>When mooring to a pier, inform first lieutenant as to the range of tide and the time of high water.</p> <p>Station line handlers.</p>
20 min	<p>When required, designated personnel fall in at quarters for entering port.</p> <p>Direct CMAA to inspect upper decks to see that crew is in proper uniform.</p>
15 min	<p>Station in-port deck watches.</p> <p>If mooring to a buoy, lower motor whaleboat with buoy detail as directed.</p> <p>Stand by to receive tugs and pilots.</p>
Upon mooring	<p>Secure main engines, gyros, and navigational radars as directed.</p> <p>If anchored, obtain navigation bearings and determine swing circle.</p>

### Conclusion

This concludes the Quartermaster rate training manual. Hopefully, you have learned a great deal about your job and of navigation in general. You are strongly encouraged to continue a strive for excellence in your search for additional knowledge of navigation and shiphandling. As mention in the preface of this RTM, the material you have covered meets only the minimum occupational requirements for the QM. Don't stop here, continue to learn and by all means pass your knowledge on to junior personnel who, with proper guidance, will continue to become the trusted navigation advisors in the fleet.



# Appendix I

## Glossary

---

**ACCELEROMETER.**—An instrument used to measure changes in velocity.

**AFTER TRUCK.**—The highest part of the aftermast.

**AGROUND.**—When any part of a ship is resting on the bottom. A ship runs aground or goes aground.

**AIR ALMANAC.**—A periodical publication of astronomical data, designed primarily for air navigation.

**ALTOCUMULUS.**—A cloud layer (or patches) within the middle level (mean height 6,500 to 20,000 feet), composed of rather flattened globular masses.

**ALTOSTRATUS.**—A sheet of gray or bluish clouds within the middle level (mean height 6,500 to 20,000 feet).

**ANCHOR BALL.**—A black circular shape hoisted to indicate that the ship is anchored.

**ANCHORED.**—Made fast to the bottom by an anchor.

**AYNGLE.**—The inclination to each other of two intersecting lines, measured by the arc of a circle intercepted between the two lines forming the angle, the center of the circle being the point of intersection.

**APPARENT TIME.**—Time based upon the rotation of the earth relative to the apparent (true) Sun.

**ARC.**—Part of a curved line, as a circle. The graduated scale of an instrument for measuring angles, as a marine sextant.

**ATMOSPHERE.**—The envelope of air surrounding Earth or other celestial body.

**AZIMUTH.**—The horizontal direction of a celestial point from a terrestrial point. It is usually measured from 000° at the reference direction clockwise through 360°.

**BAROMETER.**—An instrument for measuring atmospheric pressure.

**BASE LINE.**—The line between two transmitters operating together to provide a line of position, as in loran.

**BEARING.**—The horizontal direction of one terrestrial point from another. It is usually measured from 000° at the reference direction clockwise through 360°.

**BEARING CIRCLE.**—A ring designed to fit snugly over a compass or compass repeater and provided with vanes for observing compass bearings.

**BEARING CURSOR.**—A mechanical or electronic bearing line of a plan position indicator type of display for reading the target bearing.

**BEARING RESOLUTION.**—The minimum angular separation in a horizontal plane between two targets at the same range that will allow an operator to obtain data on either individual target.

## Appendix I, Continued

---

**BINNACLE.**—The stand in which a compass is mounted.

**BLAST.**—Signal on a ship's whistle; short, about 1 second; prolonged, 4 to 6 seconds.

**BLINKING.**—Regular shifting right and left of a loran signal to indicate that the signals are out of synchronization.

### **BROAD COMMAND**

**PENNANT.**—Personal command pennant of an officer, not a flag officer.

**BUOY.**—A floating object, other than a lightship, moored or anchored to the bottom as an aid to navigation.

**CELESTIAL EQUATOR.**—The intersection of the celestial sphere and extended plane of the equator.

**CELESTIAL NAVIGATION.**—Navigation with the aid of celestial bodies.

**CELESTIAL SPHERE.**—An imaginary sphere of infinite radius concentric with Earth on which all celestial bodies except Earth are imagined to be provided.

**CELSIUS.**—Temperature based upon a scale in which, under standard atmospheric pressure, water freezes at 0° and boils at 100°.

**CHART.**—A map intended primarily for navigational use.

**CHRONOMETER.**—A timepiece with a nearly constant rate.

**CIRROCUMULUS.**—High clouds (mean lower level above 20,000 feet), composed of small white flakes or of very small globular masses.

**CIRROSTRATUS.**—Thin, whitish, high clouds (mean lower level above 20,000 feet).

**CIRRUS.**—Detached high clouds (mean lower level above 20,000 feet) of delicate and fibrous appearance.

**CLOSE ABOARD.**—Near; within 600 yards for ship, 400 yards for boat.

**CLOSEST POINT OF APPROACH.**—The position of a contact when it reaches its minimum range to own ship.

**CLOSE UP.**—A flag that is all the way up on its halyard.

**CLOUD.**—A visible assemblage of numerous tiny droplets of water or ice crystals formed by condensation of water vapor in the air with the base above the surface of Earth.

**COAST PILOT.**—A descriptive book for the use of mariners, containing detailed information about coastal waters, harbor facilities, and so forth, of an area, particularly along the coasts of the United States.

**COLORS.**—The national flag. The ceremony of raising the flag at 0800 and lowering it at sunset aboard a ship not under way or at a shore station.

## Appendix I, Continued

---

COMMISSION PENNANT.—Narrow red, white, and blue pennant with seven stars, flown at the main-truck of a ship in commission.

COMPASS.—An instrument for determining courses steered and bearings by indicating the magnetic or true north and the ship's head.

COMPASS HEADING.—A heading relative to compass north.

COMPASS POINTS.—The 32 divisions of a compass at intervals of  $11\frac{1}{4}^{\circ}$ .

COMPUTED ALTITUDE.—Altitude of the center of a celestial body above the celestial horizon at a given time and place as determined by computation, table, mechanical device, or graphics.

CONSOL.—An electronic navigational system providing a number of rotating equisignal zones that permit determination of bearings from a transmitting station by counting a series of dots and dashes and referring to a table or special chart.

CONTOUR.—A line connecting points of equal elevation or equal depth.

CUMULONIMBUS.—A massive cloud with great vertical development, the summits of which rise in the form of mountains or towers, the upper parts often spreading out in the form of an anvil.

CUMULUS.—A dense cloud with vertical development, having a horizontal base and dome-shaped upper surface, exhibiting protuberances.

CURRENT.—Water in essentially horizontal motion. A hypothetical horizontal motion of such set and drift as to account for the difference between a dead-reckoning position and a fix at the same time.

DAY BEACON.—An unlighted beacon.

DEAD RECKONING.—Determination of position by advancing a previous position for courses and distances.

DECCA.—An electronic navigational system by which hyperbolic lines of position are determined by measuring the phase difference of synchronized continuous wave signals.

DECLINATION.—Angular distance north or south of the celestial equator and a point on the celestial sphere, measured northward or southward from the celestial equator through  $90^{\circ}$ , and labeled N or S to indicate the direction of measurement.

DEGAUSSING.—Neutralization of the strength of the magnetic field of a vessel by means of suitably arranged electric coils permanently installed in the vessel.

DEGREE.—A unit of circular measure equal to  $1/360$ th of a circle.

DEPTH.—Vertical distance from a given water level to the bottom.

DEPTH OF WATER.—The vertical distance from the surface of the water to the bottom.

## Appendix I, Continued

---

**DEPTH-SOUNDING SONAR.**—A direct-reading device for determining the depth of water in fathoms or other units by reflecting sonic or ultrasonic waves from the ocean bottom.

**DEVIATION.**—The angle between the magnetic meridian and the axis of a compass card expressed in degrees east or west to indicate the direction in which the northern end of the compass card is offset from magnetic north.

**DEW POINT.**—The temperature to which air must be cooled at constant pressure and constant water vapor content to reach saturation.

**DIP.**—Lowering a flag part way in salute or in answer and hoisting it again. A flag is "at the dip" when it is flown at about two-thirds the height of the halyards.

**DIRECTION OF RELATIVE MOVEMENT.**—The direction of motion relative to a reference point, itself usually in motion.

**DIURNAL.**—Having a period of, occurring in, or related to a day.

**DIVIDERS.**—An instrument consisting in its simple form of two pointed legs joined by a pivot and used principally for measuring distances or coordinates.

**DOPPLER.**—The observed change of frequency of a wave caused by a time rate of change of the effective distance traveled by the wave between the source and the point of observation.

**DRESSING LINES.**—The lines used in dressing ship.

**DRESSING SHIP.**—A display of national colors at all mastheads and the flagstaff. (Full dressing ship requires, in addition, a rainbow of flags from bow to stem over the mastheads.)

**DRIFT.**—The leeway of a vessel or amount of set of a tide or current; the spare end of a rope.

**EBB.**—Tidal current moving away from land or down a tidal stream.

**ELECTROMAGNETIC.**—Having both magnetic and electric properties.

**ELECTRONIC NAVIGATION.**—Navigation by means of electronic equipment.

**EQUATOR.**—The primary great circle of Earth, or a similar body, perpendicular to the polar axis.

**ESTIMATED POSITION.**—The most probable position of a craft determined from incomplete data or data of questionable accuracy.

**FAHRENHEIT TEMPERATURE.**—Temperature based upon a scale in which, under standard atmospheric pressure, water freezes at 32° and boils at 212°.

**FATHOM.**—A unit of length equal to 6 feet.

## Appendix I, Continued

---

**FIX.**—A relatively accurate position determined without reference to any former position.

**FLAGHOIST.**—A display of flags used to indicate a signal or a group of signals.

**FLAGSTAFF.**—A small vertical spar at the stem on which the ensign is hoisted.

**FLOOD TIDE.**—Tide rising or flowing toward land.

**FOG.**—A visible assemblage of numerous tiny droplets of water or ice crystals formed by condensation of water vapor in the air with the base at the surface of Earth.

**FORETRUCK.**—The highest point of the forward mast.

**FRONT.**—The intersection of a frontal surface and a horizontal plane.

**GAFF.**—A small spar abaft the mainmast from which the national ensign is flown when the ship is under way.

**GEOGRAPHICAL POSITION.**—That point on Earth at which a given celestial body is in the zenith at a specified time. Any position on the earth defined by means of its geographical coordinates.

**GNOMONIC PROJECTION.**—A map projection in which points on the surface of a sphere or spheroid, such as Earth, are conceived as projected by radials from the center to a tangent plane.

**GREAT CIRCLE.**—The intersection of a sphere and a plane through its center meridian; angular distance west of the Greenwich celestial meridian; the arc of the celestial equator, or the angle at the celestial pole, between the upper branch of the Greenwich celestial meridian and the hour circle of a point on the celestial sphere, measured westward from the Greenwich celestial meridian through 360°.

**GREENWICH HOUR ANGLE.**—Local hour angle at the Greenwich Meridian.

**GREENWICH MEAN TIME.**—Local mean time at the Greenwich Meridian; the arc of the celestial equator, or the angle at the celestial pole, between the lower branch of the Greenwich celestial meridian and the hour circle of the mean sun, measured westward from the lower branch of the Greenwich celestial meridian through 24 hours; Greenwich hour angle of the mean sun, expressed in time units, plus 12 hours.

**GROUND WAVE.**—That portion of a radio wave in proximity to, and affected by, the ground, being somewhat refracted by the lower atmosphere and diffracted by the surface of Earth.

**GUN SALUTE.**—Blank shots fired to honor a dignitary or in celebration.

**GYROCOMPASS.**—A compass having one or more gyroscopes as the directive element and tending to indicate true north.

**GYRO REPEATER.**—That part of a remote indicating gyrocompass system that repeats at a distance the indications of the master gyrocompass.

## Appendix I, Continued

---

**HALFMAST.**—To fly a flag halfway up the mast as a sign of mourning.

**HAUL DOWN.**—A term used as directive to execute a flaghoist by lowering it.

**HONORS AND CEREMONIES.**—A collective term; official guards, bands, salutes, and other activities that honor the colors, celebrate a holiday, or greet a distinguished guest or officer.

**HUMIDITY.**—The amount of water vapor in the air.

**HYPERBOLA.**—A curve that is the locus of points having a constant difference of distance from two fixed points.

**HYPERBOLIC NAVIGATION SYSTEM.**—A method of radio navigation (for example, loran) in which pulses transmitted by two ground stations are received by an aircraft or ship.

**INDEX CORRECTION.**—That correction due to index error.

**INDICATOR.**—A device or apparatus, usually partly or wholly automatic, for indicating something.

**INERTIAL NAVIGATION SYSTEM (INS).**—System designed to guide a ship by a device independent of outside information, using the inertial properties of gyroscopes.

**INLAND RULES.**—Rules of the nautical road that are applicable in most inland U.S. waters.

**INTERNATIONAL RULES.**—Rules of the nautical road made effective by agreement of the major maritime powers for use on high seas and most inland waters of the world except the United States.

**INTERPOLATION.**—The process of finding a value between two known values on a chart or graph.

**IONOSPHERE.**—That part of Earth's atmosphere between the chemopause (at a height of about 50 miles) and the ionopause (at about 250 miles).

**ISOBARS.**—Lines connecting points having the same atmospheric pressure reduced to a common datum, usually sea level.

**JOOD.**—Junior officer of the deck. The assistant to the officer of the deck.

**KNOT.**—The unit of speed that is equivalent to 1 nautical mile (6,080 feet per hour); a collective term for hitches and bends.

**LATITUDE.**—Distance north (N) or south (S) of the equator, expressed in degrees and minutes.

**LIGHT CHARACTERISTICS.**—The sequence and length of light and dark periods and the color or colors by which it is identified.

**LIGHTHOUSE.**—A distinctive structure exhibiting a major light designed to serve as an aid to navigation.

## Appendix I, Continued

---

**LIGHT LIST.**—A publication tabulating navigational lights, with their locations, candlepowers, characteristics, and so forth.

**LIGHTSHIP.**—A distinctively marked vessel anchored or moored at a charted point to serve as an aid to navigation.

**LINE OF POSITION (LOP).**—A line indicating a series of possible positions of a ship as a result of observation or measurement.

**LIST OF LIGHTS.**—A publication containing a description of every light in the world not located in the United States or its possessions.

**LOCAL APPARENT NOON.**—The instant at which the apparent (true) sun is over the upper branch of the local meridian.

**LOCAL HOUR ANGLE.**—Angular distance west of the local celestial meridian; the arc of the celestial equator or the angle at the celestial pole between the upper branch of the local celestial meridian and the hour circle of a point on the celestial sphere, measured westward from the local celestial meridian through  $360^\circ$ .

**LOCAL MEAN TIME.**—The arc of the celestial equator or the angle at the celestial pole between the lower branch of the local celestial meridian and the hour circle of the mean sun, measured westward from the lower branch of the local celestial meridian through 24 hours; local hour angle of the mean sun, expressed in time units, plus 12 hours.

**LOCUS.**—All possible positions of a point or curve satisfying stated conditions.

**LONGITUDE.**—Distance east (E) or west (W) of the prime meridian, which runs through Greenwich, England.

**LOOKOUT.**—A man stationed as a visual watch.

**LORAN.**—An electronic navigational system by which hyperbolic lines of position are determined by measuring the difference in the time of reception of synchronized pulse signals from two fixed transmitters.

**LUBBER'S LINE.**—A reference line on any direction-indicating instrument, marking the reading that coincides with the heading.

**LUNAR TIME.**—Time based upon the rotation of Earth relative to the Moon.

**MAINMAST.**—Second mast aft from the bow.

**MAIN-TRUCK.**—The highest part of the mainmast.

**MANEUVERING BOARD.**—A polar coordinate plotting sheet devised to facilitate the solution of problems involving relative movement.

**MANEUVERING SHIP.**—A ship the movements of which are defined relative to a given ship called the reference ship.

**MASTER STATION.**—The governing of two or more synchronized transmitting stations.

**MASTHEAD.**—The top of a mast.

## Appendix I, Continued

---

MEAN TIME.—Time based upon the rotation of Earth relative to the mean Sun.

MERCATOR PROJECTION.—A conformal cylindrical map projection in which the surface of a sphere or spheroid, such as Earth, is conceived as developed on a cylinder tangent along the equator.

MERIDIAN.—A north-south reference line, particularly a great circle through the geographic poles of Earth.

MESSAGE.—Any thought briefly stated in plain or secret language in a form suitable for rapid transmission.

METER.—The basic unit of length of the metric system, equal to the distance at 0°C between two lines on a standard platinum-iridium bar.

MICROSECOND.—One-millionth of a second.

MILLIBARS.—A unit of measure of atmospheric pressure.

MINUTE.—The sixtieth part of a degree of arc.

MODULATOR.—That part of radio equipment that alters the amplitude, frequency, or phase of a radio signal in accordance with speech or a signal, or that regulates the length of a pulse.

MORSE CODE.—Dots and dashes used in communications in place of letters, numerals, and punctuation.

MRM.—Distance of relative movement. The distance along the relative movement line between any two specified points or time.

NAUTICAL ALMANAC.—A periodical publication of astronomical statistics useful to, and designed primarily for, marine navigation, particularly the American Nautical Almanac published by the U.S. Naval Observatory.

NAUTICAL ASTRONOMY.—Navigational astronomy.

NAUTICAL MILE.—A unit of distance used principally in navigation. See Knot.

NAVIGATION.—The process of directing the movement of a craft from one point to another.

NEAP TIDES.—The tides occurring near the times of first and last quarter of the moon when the range of tide tends to decrease.

NIMBOSTRATUS.—A dark, low, shapeless cloud layer (mean upper level below 6,500 feet), usually nearly uniform; the typical rain cloud.

NOMOGRAM.—A diagram showing to scale the relationship between several variables in such a manner that the value of one that corresponds to known values of the others can be determined graphically.

NOT UNDER COMMAND.—A ship disabled or uncontrollable.



## Appendix I, Continued

---

**OFFICIAL VISIT.**—A formal visit of courtesy requiring special honors and ceremonies.

**OMEGA.**—An electronic navigational system.

**OSCILLOSCOPE.**—An instrument for producing a visual representation of oscillations or changes in an electric current.

**PARALLAX.**—The difference in the apparent direction or position of an object when viewed from different points.

**PARALLEL.**—A circle on the surface of Earth parallel to the plane of the equator and connecting all points of equal latitude; a circle parallel to the primary great circle of a sphere or spheroid.

**PASSING HONORS.**—Honors, except gun salutes, that are rendered by a ship when ships or embarked officials or officers pass close aboard.

**PEAK.**—The topmost end of the gaff from which the ensign is flown while a ship is under way.

**PELORUS.**—A dumb compass, or a compass card (called a pelorus card) without a directive element, suitably mounted and provided with vanes to permit observation of relative bearings, unless used in conjunction with a compass, to give true or magnetic bearings.

**PHONETIC ALPHABET.**—A system of words that represents each letter of the alphabet.

**PILOTING.**—Navigation involving frequent or continuous determination of position or a line of position relative to geographical points to a high order of accuracy.

**PIPE THE SIDE.**—A ceremony conducted at the brow of a ship in which sideboys are paraded and the boatswain's pipe is blown.

**PLAN POSITION INDICATOR.**—A radarscope that has a sweep that originates in the center and moves to the outer edge of the scope and presents an overflow of a given area.

**PLOTTING SHEET.**—A blank chart, usually on the Mercator projection, showing only the graticule and a compass rose so the plotting sheet can be used for any longitude.

**POLAR DISTANCE.**—Angular distance from a celestial pole.

**POSITION.**—A point defined by stated or implied coordinates, particularly one on the surface of Earth.

**PRESSURE.**—Force per unit area. The pressure exerted by the weight of Earth's atmosphere is called atmospheric or, if indicated by a barometer, barometric pressure.

**PROLONGED BLAST.**—A blast on the whistle of from 4 to 6 seconds duration.

**PROPAGATION.**—A transmission of electromagnetic energy.

## Appendix I, Continued

---

**PRO WORD.**—Pronounceable words or phrases that have been assigned meanings for expediting message handling on radio circuits where procedure is used.

**PSYCHROMETER.**—A type of hygrometer (an instrument for determining atmospheric humidity) consisting essentially of dry-bulb and wet-bulb thermometers.

**PULSE-REPETITION RATE.**—The rate at which recurrent pulses are transmitted, usually expressed in pulses per second.

**QUARTERDECK.**—The portion of the weather deck designated by the commanding officer for official ceremonies.

**RADAR.**—(Radio Detection And Ranging) is a method of determining the distance to and direction of objects by sending out a beam of microwave radio energy and detecting the returned reflections.

**RANGE.**—Two or more objects in line.

**RANGE MARKER.**—A distance marker, as on a radar PPI.

**RANGE STROBE.**—An electronic range marker on a radar PPI.

**RECIPROCAL.**—A direction 180° from a given direction.

**REFERENCE SHIP.**—A ship to which relative movement of other ship is referred.

**REFRACTION.**—The change in direction of motion of a ray of radiant energy as it passes obliquely from one medium into another in which the speed of propagation is different.

**RELATIVE BEARING.**—Bearing relative to heading or to the ship.

**RELATIVE MOTION.**—Apparent motion; relative movement.

**RELATIVE MOVEMENT LINE.**—A line connecting successive positions of a maneuvering ship relative to a reference ship.

**RELATIVE PLOT.**—A plot of the successive positions of a ship relative to a reference point, which is usually in motion.

**ROOT MEAN SQUARE.**—The square root of the arithmetical mean of the squares of a group of numbers.

**RUNNING FIX.**—A position determined by crossing lines of position obtained at different times and advanced or retired to a common time.

**SAILING DIRECTIONS.**—A descriptive book for the use of mariners, containing detailed information of coastal waters, harbor facilities, and so forth, of an area.

**SCALE.**—The ratio between the linear dimensions of a chart, map, drawing, and so forth, and the actual dimensions represented.

## Appendix I, Continued

---

**SEMIDIAMETER.**—The radius of a closed figure. Half the angle at the observer subtended by the visible disk of a celestial body.

**SET.**—The direction toward which a current flows.

**SEXTANT.**—A double-reflecting instrument for measuring angles, primarily altitudes of celestial bodies.

**SHORAN.**—A precision electronic position fixing system using a pulse transmitter and receiver and two transponder beacons at fixed points.

**SIDEREAL HOUR ANGLE.**—Angular distance west of the vernal equinox; the arc of the celestial equator or the angle at the celestial pole between the hour circle of the vernal equinox and the hour circle of a point on the celestial sphere, measured westward from the hour circle of the vernal equinox through 360°.

**SIDEREAL TIME.**—Time based upon the rotation of Earth relative to the vernal equinox.

**SKY WAVE.**—An indirect radio wave that travels from the transmitting antenna into the sky, where the ionosphere bends it back toward the Earth.

**SLACK WATER.**—The condition when the speed of a tidal current is zero, especially the momentary condition zero speed when a reversing current changes direction.

**SOLAR TIME.**—Time based upon the rotation of Earth relative to the Sun.

**SOUNDING.**—Measured or charted depth of water or the measurement of such depth.

**SPEED OF RELATIVE MOVEMENT.**—Speed relative to a reference point itself usually in motion.

**SPRING TIDES.**—The tides occurring near the times of full moon and new moon when the range of tide tends to increase.

**STADIMETER.**—An instrument for determining the distance to an object of known height by measuring the angle subtended at the observer by the object.

**STAND.**—The condition at high or low tide when there is no change in the height of the water.

**STAR FINDER.**—A device to facilitate the identification of stars.

**STATUTE MILE.**—A unit of distance equal to 5,280 feet.

**STRATOCUMULUS.**—Low clouds (mean upper level below 6,550 feet), composed of a layer or patches of globular masses or rolls.

**STRATUS.**—A low cloud (mean upper level below 6,550 feet) in a uniform layer.

**TANGENT.**—The ratio of the side opposite an acute angle of a plane right triangle to the shorter side adjacent to the same angle. A straight line, curve, or surface touching a curve or surface at one point.

**TELESCOPIC ALIDADE.**—A device used with a gyro repeater for taking bearings.

## Appendix I, Continued

---

**TEMPERATURE.**—Intensity or degree of heat. Fahrenheit temperature is based upon a scale in which water freezes at 32° and boils at 212°.

**TERRESTRIAL SPHERE.**—The Earth.

**THERMOMETER.**—An instrument for measuring temperature.

**THREE-ARM PROTRACTOR.**—An instrument consisting essentially of a circle graduated in degrees to which is attached one fixed arm and two arms pivoted at the center and provided with clamps so they can be set at any angle to the fixed arm within the limits of the instrument.

**TIDE.**—The periodic rise and fall of the surface of oceans, bays, and so forth, due principally to the gravitational attraction of the Moon and Sun for the rotating Earth.

**TIME DIAGRAM.**—A diagram in which the celestial equator appears as a circle and celestial meridians and hour circles as radial lines, used to facilitate solution of time problems and others involving arcs of the celestial equator or angles at the pole by indicating relations between various quantities involved.

**TRACK.**—To follow the movements of an object, as by radar or an optical system.

**TRANSMITTER.**—One who or that which transmits or sends anything, particularly a radio transmitter.

**TROPICAL CYCLONE.**—A violent cyclone originating in the tropics.

**TWILIGHT.**—The periods of incomplete darkness following sunset (evening twilight) or preceding sunrise (morning twilight).

**UNION JACK.**—Flag flown at the bow of a ship moored or anchored, consisting of the union of the national flag. Also flown in the boat of a high official and at a yardarm during a general court-martial or court of inquiry.

**UPPER BRANCH.**—That half of a meridian or celestial meridian from pole to pole that passes through a place or its zenith.

**VARIATION.**—The angle between the magnetic and geographical meridians at any place, expressed in degrees east or west to indicate the direction of magnetic north from true north.

**VECTOR.**—A straight line representing both direction and magnitude.

**VECTOR DIAGRAM.**—A diagram of more than one vector drawn to the same scale and reference direction and in correct position relative to each other.

**VERNAL EQUINOX.**—That point of intersection of the elliptical and the celestial equator occupied by the Sun as it changes from south to north declination on or about March 21.

**VISIBILITY.**—The extreme horizontal distance at which prominent objects can be seen and identified by the unaided eye.

## Appendix I, Continued

---

**VOICE RADIO.**—Electronic communications equipment that transmits the speaker’s voice through the air on radio waves to an appropriately tuned receiver.

**WAVELENGTH.**—The distance in the direction of advance between the same phase of successive waves.

**WEATHER.**—The state of the atmosphere as defined by various meteorological elements, such as temperature, pressure, wind speed, direction, humidity, cloudiness, and precipitation.

**WIND.**—Moving air, especially a mass of air having a common direction of motion.

**YARDARM.**—The port or starboard half of a spar set athwartships across the upper part of a mast.

**ZONE TIME.**—The local mean time of a reference or zone meridian whose time is kept throughout a designated zone.



# Appendix II

## Reference List

---

Note: Although the following references were current when this TRAMAN was published, their continued currency cannot be assured. Therefore, you need to be sure that you are studying from the latest version.

### Chapter 1

*Defense Mapping Agency Catalog of Maps, Charts, and Related Products*, Pub. I-N, Defense Mapping Agency, Washington, D.C., 1994.

*Dutton's Navigation and Piloting*, 14th ed., Naval Institute Press, Annapolis, 1985.

*Navigation Standards and Procedures*, COMNAVSURFLANT/PACINST 3530.4, Commander Naval Surface Force, Atlantic Fleet, Norfolk, Va., Pacific Fleet, San Diego, Calif., October 1994.

*Notice to Mariners*, Defense Mapping Agency Hydrographic/Topographic Center, Washington, D.C., 1994.

### Chapter 2

*American Practical Navigator* (Bowditch), HO-9 Vol. I, Defense Mapping Agency Hydrographic/Topographic Center, Washington, DC., 1984.

*Dutton's Navigation and Piloting*, 14th ed., Naval Institute Press, Annapolis, 1985.

*Handbook of Magnetic Compass Adjustment*, 4th ed., Pub. No. 226, Defense Mapping Agency Hydrographic/Topographic Center, Washington, D.C., 1980.

*Magnetic Compass Record Book*, NAVSEA 3120/3, Naval Sea Systems Command, Washington, D.C.

*Magnetic Compass Table*, NAVSEA 3120/4, Naval Sea Systems Command, Washington, D.C.

### Chapter 3

*American Practical Navigator* (Bowditch), HO-9 Vol. I, Defense Mapping Agency Hydrographic/Topographic Center, Washington, D.C., 1984.

*Current Tables*, Atlantic Coast of North America, Defense Mapping Agency, Washington, D.C., 1994.

## Reference List, Continued

---

*Dutton's Navigation and Piloting*, 14th ed., Naval Institute Press, Annapolis, 1985.

*Navigation Standards and Procedures*, COMNAVSURFLANT/PACINST 3530.4, Commander Naval Surface Force, Atlantic Fleet, Norfolk, Va., Pacific Fleet, San Diego, Calif., October 1994.

*Tide Tables*, East Coast of North and South America, Defense Mapping Agency, Washington, D.C., 1994.

### Chapter 4

*Dutton's Navigation and Piloting*, 14th ed., Naval Institute Press, Annapolis, 1985.

*Light List*, Vol. III, Atlantic and Gulf Coasts, U.S. Department of Transportation, U.S. Coast Guard, 1993.

*Navigation Rules*, USCG Commandant Instruction M16672.2B, 17 August 1990.

### Chapter 5

*Dutton's Navigation and Piloting*, 14th ed., Naval Institute Press, Annapolis, 1985.

### Chapter 6

*Dutton's Navigation and Piloting*, 14th ed., Naval Institute Press, Annapolis, 1985.

### Chapter 7

*Current Tables*, Atlantic Coast of North America, Defense Mapping Agency, Washington, D.C., 1994.

*Dutton's Navigation and Piloting*, 14th ed., Naval Institute Press, Annapolis, 1985.

*Tide Tables*, East Coast of North and South America, Defense Mapping Agency, Washington, D.C., 1994.



## Reference List, Continued

---

### Chapter 8

- Dutton's Navigation and Piloting*, 14th ed., Naval Institute Press, Annapolis, 1985.
- Navigation Standards and Procedures*, COMNAVSURFLANT/PACINST 3530.4, Commander Naval Surface Force, Atlantic Fleet, Norfolk, Va., Pacific Fleet, San Diego, Calif., October 1994.
- SRN-19 Operation Manual, Shipboard Operations and Maintenance Manual*, NAVELEX 0967-LP-634-9010, Naval Electronics Command, Charleston, S.C. 1977.
- Satellite Signals Navigation Set AN/WRN-6(V)*, COMSPAWARSSYSCOM PMW-167, Commander, Naval Space and Naval Warfare Systems Command, Washington, D.C., March 1992.

### Chapter 9

- Dutton's Navigation and Piloting*, 14th ed., Naval Institute Press, Annapolis, 1985.

### Chapter 10

- American Practical Navigator* (Bowditch), HO-9 Vol. I, Defense Mapping Agency Hydrographic/Topographic Center, Washington, D.C., 1984.
- Dutton's Navigation and Piloting*, 14th ed., Naval Institute Press, Annapolis, 1985.
- Manual for Ships Surface Weather Observations*, NAVOCEANCOMINST 3144.1 C, Commander Naval Oceanography Command, Stennis Space Center, Miss., 1984.

### Chapter 11

- Allied Maritime Tactical Instructions and Procedures*, ATP 1, Volume 1, 1983.
- Dutton's Navigation and Piloting*, 14th ed., Naval Institute Press, Annapolis, 1985.
- Instructions for Ships Deck Log*, OPNAVINST 3100.7B, Office of the Chief of Naval Operations, Washington, D.C., March 1986, Revised July 1994.
- Naval Shiphandling* (Crenshaw's), 4th ed., U.S. Naval Institute Press, Annapolis, 1985.

## Reference List, Continued

---

*Navigation Standards and Procedures*, COMNAVSURFLANT/PACINST 3530.4, Commander Naval Surface Force, Atlantic Fleet, Norfolk, Va., Pacific Fleet, San Diego, Calif., October 1994.

### Chapter 12

*American Practical Navigator* (Bowditch), HO-9 Vol. I, Defense Mapping Agency Hydrographic/Topographic Center, Washington, D.C., 1984.

*Dutton's Navigation and Piloting*, 14th ed., Naval Institute Press, Annapolis, 1985.

*Navigation Rules*, USCG Commandant Instruction M16672.2B, 17 August 1990.

*Navigation Standards and Procedures*, COMNAVSURFLANT/PACINST 3530.4, Commander Naval Surface Force, Atlantic Fleet, Norfolk, Va., Pacific Fleet, San Diego, Calif., October 1994.

# Index

---

## A

Acceleration/deceleration table, 11-9

Advance, 11-7

Advancing LOPs, 9-30

Aids to navigation, 4-7  
light cycle, 4-7

Almanacs, 3-9

Alternating lights, 4-20

Altitude corrections, 9-19

Amplitude of the Sun, 9-12

AN-SRN-19, 8-43

AN/WRN-6, 8-45

Anemometers, 10-20

Aneroid barometer, 10-11

Angle of turn, 11-8

Apparent time, 5-3

Approach track, 12-15

Arc to time, 5-7

Atmosphere, 10-3

Atmospheric pressure, 10-11

Azimuth by Polaris, 9-11

Azimuth circle, 2-22

Azimuth of the Sun, 9-2

## B

Bearing circle, 2-22, 2-25

Bridge equipment, 11-3

Bridge watch personnel, 11-21

Buoy identification, 4-27

Buoyage systems, 4-28

Buoys, 4-24

## C

Calculating true wind, 10-25

Celestial coordinate system, 6-3  
celestial equator, 6-3  
declination, 6-3  
first point of Aries, 6-3  
Greenwich hour angle, 6-3  
local hour angle, 6-3  
sidereal hour angle, 6-3

Celestial LOP, 9-16

Celestial sphere, 6-2, 6-4

Chronometer, 5-14  
average daily rate, 5-18  
error, 5-14

Circulation of the wind, 10-4

Cloud characteristics, 10-8

Cloud formations, 10-6

CNOC 3140/8, 10-30

Coast pilots, 3-4

# Index

---

- Coastal tracks, 12-6
  - constructing, 12-6
  - planning, 12-6
- Cold fronts, 10-17
- Commanding officers Night Order Book, 11-26
- Compass comparison, 2-18
- Compass error calculations, 2-15
- Compasses, 2-6
  - cautions, 2-6
  - standard, 2-6
  - steering, 2-6
- Convert arc to time, 5-10
  - nautical almanac, 5-10
- Convert time, 5-11
  - GMT to ZT, 5-12
  - ZT to GMT, 5-11
- D**
- Danger bearings, 12-10
- Daybeacons, 4-19
- Degaussing System, 2-13
  - degaussing coils, 2-14
- Deviation, 2-11
- Dew point, 10-29
- Dip, 9-21
- Directional lights, 4-18
- Distances between ports, 3-8
- DR plot, 8-3
  - example, 8-10
  - labeling, 8-11
  - six rules, 8-3
  - terms, 8-4
- Drag circle, 12-15
- Drift angle, 11-8
- E**
- Earth's magnetic field, 2-3
- Electric psychrometer, 10-29
- Equation of time, 5-4
- External communications, 11-20
- F**
- Fathometer, 8-41
- Final diameter, 11-7
- Fixes, 8-20
- Fleet guides, 3-4
- Fog, 10-10
- Frontal systems, 10-15
- Frontal weather, 10-13
- G**
- Great-circle tracks, 12-2
  - constructing, 12-2
  - planning, 12-2
- Gyro error by terrestrial range, 2-32
- Gyro error by trial and error, 2-33

## Index, Continued

---

Gyrocompass, 2-20  
accuracy, 2-20  
components, 2-20  
operation, 2-20  
repeaters, 2-2 1

Gyrocompass Error, 2-23

Gyrocompass Repeaters, 11-6

### H

Head bearing, 12-15

Helm orders, 11-12

Helm unit, 11-3

High-etae clouds, 10-8

Ho, 9-23

Horse latitudes, 10-5

### I

IALA system A, 4-29

IALA system B, 4-29

Index error, 9-21

International date line, 5-13

Intracoastal waterway, 4-38

Isobars, 10-13

### J

JOOD, 11-24

### K

Kick, 11-8

### L

Labeling LOPs, 8-20

Labeling the DR plot, 8-11

Lee helm, 11-3

Letting-go bearing, 12-15

Letting-go circle, 12-15

Light colors, 4-20

Light List, 4-3, 4-4

Light towers, 4-15

Lighted aids to navigation, 4-7

Lighthouses, 4-14

Lines of position, 8-20

List of lights, 3-6

Local apparent noon, 9-36

LORAN-C, 8-42

Low-etae clouds, 10-9

Luminous range diagram, 4-12

### M

Magnetic compass, 2-2, 2-7  
components, 2-7  
operation, 2-7

Magnetic compass adjustment, 2-19

Magnetic compass deviation tables, 2-10

## Index, Continued

---

Magnetic compass error, 2-9  
  deviation, 2-9  
  induced magnetism, 2-9  
  permanent magnetism, 2-9

Magnetism, 2-2

Maneuvering and warning signals, 4-44

Marine sextant, 8-24  
  finding the index error, 8-28  
  positive index error, 8-3 1  
  negative index error, 8-32

Master helmsman, 11-11

Mean solar time, 5-3

Mid-etage clouds, 10-8

Minor lights, 4-19

### N

Nautical almanac, 6-5

Nautical slide rule, 8-7

Navigation brief, 12-22

Navigation team, 8-19

Navigational lights, 11-15

Navigational radar, 8-47

Navstar global positioning system, 8-44  
  GPS signals, 8-45

### O

Observing sunrise and sunset, 11-40

### P

Parallax, 9-22

Parallel motion protractor, 2-22, 2-26  
  setup, 2-27

Pilot charts, 3-7

Piloting, 8-18

Pivot point, 11-7

Plan of intended movement (PIM), 8-12

Plotting instruments, 8-13

Plotting LOPs, 9-28

Plotting techniques, 8-15

Polar region winds, 10-5

Post anchoring procedure, 12-18

Precision snchoring, 12-13

Preparing to depart port, 12-23

Preparing to enter port or restricted waters,  
  12-26

Pressure areas, 10-13

Prevailing westerlies, 10-5

Publication correction, 3-10

Publications, 3-2  
  quick reference guide, 3-2

## Index, continued

---

### Q

QMOW, 12-42  
  anchor watch, 11-42  
  general duties, 11-34  
  In port, 11-42  
  Relieving the QMOW, 11-25

### R

Racons, 4-23

RADAR fixes, 8-50

Radio direction finder, 8-51

Range circles, 12-15

Ranges, 4-16

Red and yellow soundings, 12-8

Refraction, 9-21

Relative bearings, 8-22

Relative humidity, 10-27

Rendering honors, 11-40

Reporting contacts, 11-41

Restricted visibility, 4-50

Restricted water tracks, 12-7  
  constructing, 12-7  
  planning, 12-7

Rude Starfinder, 6-14

Rules of the Road, 4-39

Running fix, 8-39

### S

Sailing directions, 3-5

Satellite Navigation Systems, 8-43

SCC alarms, 11-6

Sector lights, 4-21

Selecting an anchorage, 12-13

Selecting landmarks, 8-20

Semidiameter, 9-22

Set and drift, 11-39

Sextant angles, 8-33

Shifting steering control, 11-6

Ship's characteristics, 11-7

Ship's clocks, 5-13

Ship's inertial navigation system, 8-51

Ship's position reports, 11-40

Ship's speed, 8-9

Shiphandling, 11-7

Sight reduction, 9-31  
  stars, planets, and the Moon using Pub  
    229, 9-31  
  sunline using Pub 229, 9-24  
  using Pub 249, 9-32

Signals between vessels, 4-42

Signals used to attract attention, 4-51

## Index, Continued

---

- Slide bar technique, 12-8
- Sling psychrometer, 10-27
- Solar day, 5-3
- Sound signals, 4-37
- Special submarine signals, 4-53
- Standard time zones, 5-6
- Star time, 6-10
- Steering and sailing rules, 4-40
  - crossing situation, 4-41
  - head on situation, 4-40
  - overtaking situation, 4-41
- Steering control consoles (SCC), 11-3
- Steering pumps, 11-5
- Steering the ship, 1 1-1
  - techniques, 11-13
- Swing circle, 12-15
- Swingers or revolvers, 8-37
- T**
- Tactical diameter, 11-7
- Telescopic alidade, 2-22, 2-30
- Temperature, 10-26
- The ship's Deck Log, 11-27
- Tidal current tables, 3-7
- Tide tables, 3-7
- Time, speed, and distance, 8-5
  - 3-minute rule, 8-6
  - table 19 of *Bowditch*, 8-5
- Time ticks, 5-15
- Timepiece Rate Book, 5-17
- Timing celestial observations, 5-19
- Tradewinds, 10-5
- Transfer, 11-7
- Turn bearings, 12-8
- Turn ranges, 12-8
- Turning circle, 11-7
- V**
- Variation, 2-4
  - determine local variation, 2-5
- Visibility of lights, 4-8
  - computed range, 4-10
  - geographic range, 4-10
  - horizon distance, 4-10
  - luminous range, 4-10
  - meteorological visibility, 4-10
  - nominal range, 4-10
- Visual estimation of wind speed, 10-23
- W**
- Warm fronts, 10-15
- Weather observation, 10-30
- Weather observation and reporting, 10-34
- Wind, 10-19



## **Index,** Continued

---

Wind Measuring Set AN/PMQ-3, 10-21

Wind speed, 10-19



---

---

# *Assignment Questions*

---

---

**Information:** The text pages that you are to study are provided at the beginning of the assignment questions.



ASSIGNMENT 1

Textbook Assignment: "Compasses," chapter 2, pages 2-1 through 2-33.

1-1. Which of the following definitions best describes the term "magnetism"?

1. The characteristic properties passed by magnets
2. A phenomenon of nature known only by its effects
3. The magnetic, or attractive, power of all metals

1-2. What are the two types of magnetism?

1. North and South
2. Hard and soft
3. Permanent and induced
4. Mechanical and corrosive

1-7. The south-seeking end of a bar magnet has what type of magnetism?

1. Red magnetism
2. Blue magnetism
3. Negative magnetism
4. Permanent magnetism

1-8. What Earth component is the limiting factor of a magnetic compass?

1. Magnetic poles
2. Magnetic equator
3. Vertical
4. Horizontal

1-9. Which of the following facts is NOT consistent with variation?

1. Earth's magnetic properties are not uniformly distributed
2. Earth's magnetic properties are not at the same location as the geographic poles
3. The closer your ship is to the equator, the less the variation will be
4. Magnetic lines of force are called magnetic meridians

IN ANSWERING QUESTIONS 1-3 THROUGH 1-5 SELECT THE TYPE OF MAGNETISM FROM COLUMN B THAT MATCHES THE DEFINITION IN COLUMN A NOT ALL RESPONSES ARE USED AND RESPONSES MAY BE USED MORE THAN ONCE.

A. DEFINITION

B. TYPES OF MAGNETISM

1-3. Magnetism caused by the influence of an external force

1. Induced
2. Natural

1-4. Magnetism retained for long periods, unless a demagnetizing force is applied

3. Residual
4. Permanent

1-5. Magnetism that remains after a magnetizing force is removed

1-10. The difference between the geographic North Pole and the magnetic North pole is defined by which of the following terms?

1. Permanent magnetism
2. Induced magnetism
3. Variation
4. Deviation

1-11. When a variation for an area is figured, what factor determines which compass rose should be used?

1. The one that has the smallest variation
2. The one that has the smallest correction
3. The one that has the latest year indicated
4. The one that is closest to your position

1-6. The Earth's magnetism in the Northern and Southern Hemispheres are called what types of magnetism?

1. Positive and negative magnetism
2. Permanent and induced magnetism
3. North and south magnetism
4. Blue and red magnetism

- 1-12. The compass rose indicates a variation of  $9^{\circ} 42.0'$  E (1976), with an annual decrease of  $2'$ . What is the variation in 1995?
1.  $9^{\circ} 00'$  E
  2.  $9^{\circ} 04'$  E
  3.  $10^{\circ} 00'$  E
  4.  $10^{\circ} 03'$  E
- 1-13. What U.S. Navy vessels are provided with a magnetic steering compass?
1. All Navy vessels
  2. Combat vessels only
  3. Surface ships and craft only
  4. Vessels with wooden hulls only
- 1-14. Of the following locations aboard ship, in which one is the steering compass usually located?
1. Centerline
  2. Aft of the beam
  3. Portside to the helmsman
  4. Adjacent to the chart table
- 1-15. If a ship has two magnetic compasses, how is the second compass referred?
1. Secondary compass
  2. Steering compass
  3. Standard compass
  4. Alternate compass
- 1-16. In the term " $137^{\circ}$  PSC", what does the PSC stand for?
1. Per standard compass
  2. Per ship's compass
  3. Per steering compass
  4. Pilothouse steering compass
- 1-17. What magnetic compass is usually the most accurate?
1. The steering compass
  2. The standard compass
  3. The ship's compass
  4. The portable steering compass
- 1-18. For best reliability, the magnetic compass should be kept free of sources of induced magnetism.
1. True
  2. False

IN ANSWERING QUESTIONS 1-19 THROUGH 1-22, SELECT THE FUNCTION FROM COLUMN B THAT MATCHES THE COMPONENT IN COLUMN A. RESPONSES ARE USED ONLY ONCE.

<u>A. COMPONENT</u>	<u>B. FUNCTION</u>
1-19. Card	1. Used to align the compass
1-20. Magnets	2. Made of nonmagnetic material
1-21. Gimbals	3. Graduated in degrees from 0 to 359
1-22. Binnacle	4. Permits compass to remain level

---

1-23. Which of the following type(s) of magnetism influence(s) deviation?

1. Permanent only
2. Induced only
3. Residual
4. Permanent and induced

IN ANSWERING QUESTIONS 1-24 THROUGH 1-27, SELECT THE MAGNETISM FROM COLUMN B THAT MATCHES THE CHARACTERISTIC IN COLUMN A. NOT ALL RESPONSES ARE USED AND RESPONSES MAY BE USED MORE THAN ONCE.

<u>A. CHARACTERISTIC</u>	<u>B. MAGNETISM</u>
1-24. Hard iron	1. Permanent
1-25. Soft iron	2. Residual
1-26. Created in the ship's structure during construction	3. Induced
1-27. Varies according to the intensity of the component of Earth's field	4. Natural

---

1-28. What is the most common method of determining deviation at sea?

1. Comparing past and present compass headings against a gyrocompass
2. Verifying compass records against a deviation table
3. Recording the compass readings on all intercardinal headings
4. Swinging ship

- 1-29. All deviation is removed after a magnetic compass is adjusted.
1. True
  2. False
- 1-30. Which of the following degaussing coils counteracts the ship's longitudinal permanent and induced magnetism?
1. A
  2. F
  3. M
  4. Q
- 1-31. Which of the following degaussing coils will counteract the ship's vertical permanent and induced magnetism?
1. A
  2. F
  3. L
  4. M

- 1-37. Which of the following types of headings may be used to name a course or heading?
1. True
  2. Magnetic
  3. Compass
  4. All of the above
- 1-38. When correcting or uncorrecting the compass from one heading expression to another, which of the following formulas is correct?
1. Correcting, add east deviation
  2. Correcting, add west variation
  3. Uncorrecting, add east variation
  4. Uncorrecting, subtract east deviation
- 1-39. Converting from true course to compass course is called uncorrecting the compass.
1. True
  2. False
- 1-40. How often is the magnetic compass adjusted?
1. Quarterly
  2. Semiannually
  3. Annually
  4. When the deviation exceeds 3°

IN ANSWERING QUESTIONS 1-32 THROUGH 1-35 SELECT THE DESCRIPTION FROM COLUMN B THAT MATCHES THE DEGAUSSING COIL IN COLUMN A. RESPONSES ARE ONLY USED ONCE.

<u>A. COILS</u>	<u>B. DESCRIPTIONS</u>
1-32. A	1. Made up of loops in vertical planes parallel to the ship's frames
1-33. F	2. Encircles the after 1/3 of the ship
1-34. L	3. Encircles the forward 1/3 of the ship
1-35. Q	4. Made up of loops in vertical fore-and-aft planes

- 1-36. What coil serves the same purpose as the F coil?
1. A
  2. L
  3. Q
  4. M

TO STEER MAGNETIC COURSE	WITH VARIATION	TRUE COURSE	WITH GYRO ERROR	HEADING PER GYRO COMPASS
DEGREES	DEGREES	DEGREES	DEGREES	DEGREES
000	4W	A	0	354
180	9E	189	0	189
270	4W	B	1E	C
315	8E	323	3E	320
225	13W	212	3W	215
358	D	002	E	007

26NVJ089

Figure 1A

COMPUTE TRUE HEADINGS IN ANSWERING QUESTIONS 1-41 THROUGH 1-43. REFER TO FIGURE 1A.

- 1-41. What is the value of A?
1. 354
  2. 356
  3. 004
  4. 000

- 1-42. What are the values of B and C?
1. 274 and 273
  2. 266 and 265
  3. 266 and 267
  4. 274 and 275
- 1-43. What are the values of D and E?
1. 4W and SE
  2. 6W and SE
  3. 4E and SW
  4. 4E and 6W
- 1-44. The comparison of which two headings indicates deviation?
1. True and magnetic
  2. True and steering
  3. Steering and standard
  4. Magnetic and standard
- 1-45. The comparison of which two headings indicates variation?
1. True and steering
  2. True and magnetic
  3. True and standard
  4. Gyro and true
- 1-46. If your ship is involved in an underway replenishment, how often should the gyro check be made?
1. Every 15 minutes
  2. Every 30 minutes
  3. Once an hour
  4. Once every 4 hours
- 1-47. Which publication is used to swing ship?
1. H.O. 229
  2. H.O. 226
  3. H.O. 251
  4. H.O. 266
- 1-48. In most cases, how many hours should it take to successfully swing ship?
1. 1
  2. 2
  3. 3
  4. 4
- 1-49. Swinging ship may be accomplished anytime.
1. True
  2. False
- 1-50. How soon prior to getting under way should the gyrocompass be lit off?
1. 1 hr
  2. 2 hr
  3. 3 hr
  4. 4 hr
- 1-51. Aboard ship, the master gyro should be located in which of the following places?
1. Where least effected by ships motion
  2. Where least effected by pitch and roll
  3. Where it is safe from battle damage
  4. All of the above
- 1-52. What is the maximum mechanical error allowed in a properly functioning gyrocompass?
1. 10
  2. 20
  3. 50
  4. 40
- 1-53. Where are gyro repeaters located?
1. Pilothouses and bridgewings
  2. After steering
  3. Secondary conning station
  4. All ship's control stations
- 1-54. How often is gyro error determined?
1. Once a watch
  2. Once every 4 hours
  3. Once a day
  4. Twice a day
- 1-55. Which method of checking the accuracy of a gyro compass is called the Franklin technique?
1. Terrestrial range
  2. Azimuth of Sun
  3. Trial and error
  4. Amplitude of Sun
- 1-56. Which line should be used to align a PMP with a nautical chart?
1. Latitude
  2. Longitude
  3. Any straight line
  4. Rhumb line
- 1-57. A telescopic alidade fits what size of gyro repeater?
1. 6 in.
  2. 7 1/2 in.
  3. 8 in.
  4. 10 in.



- 1-58. What is the disadvantage of obtaining gyro error by terrestrial range?
1. Difficult to see unlighted ranges at night
  2. Only as accurate as the bearing recorder
  3. Only as accurate as the bearing taker
  4. All of the above
- 1-59. Most harbors will have at least how many sets of ranges?
1. One
  2. Two
  3. Three
  4. Four
- 1-60. When should the Franklin technique of determining gyro error be used?
1. In open ocean
  2. When entering or leaving port
  3. Prior to getting under way
  4. All of the above

ASSIGNMENT 2

Textbook Assignment: "The Nautical Road," chapter 4, "Basics of Time," chapter 5, and "Introduction to Celestial Navigation," chapter 6, pages 4-1 through 6-14.

---

- 2-1. Which of the following lights has a regularly repeated flash not to exceed 30 flashes per minute?
1. Single flashing
  2. Interrupted quick flashing
  3. Quick flashing
  4. Continuous quick flashing
- 

IN ANSWERING QUESTIONS 2-2 THROUGH 2-4, SELECT FROM COLUMN B THE DESCRIPTION THAT MATCHES THE ABBREVIATION IN COLUMN A. NOT ALL RESPONSES WILL BE USED.

A. ABBREVIATIONS

B. DESCRIPTIONS

- |              |                         |
|--------------|-------------------------|
| 2-2. Oc      | 1. Group occulting      |
| 2-3. Oc(2)   | 2. Composite occulting  |
| 2-4. Oc(2+1) | 3. Single occulting     |
|              | 4. Continuous occulting |
- 

- 2-5. What color is an odd-numbered daymarker?

1. Yellow only
2. Red only
3. Green
4. Yellow and red

- 2-6. What shape is an even-numbered daymarker?

1. Round
2. Square
3. Octagonal
4. Triangle

- 2-7. What color is a spherical buoy?

1. White only
2. Red only
3. Yellow
4. White and red

- 2-8. When transiting the western rivers of the Intracoastal Waterway, what is indicated by the number on a navigation aid?

1. Buoy number
2. Daymarker number
3. Mileage from a fixed point
4. Mileage since entering the river

- 2-9. How many rules comprise the main buoy of the rules of the road?

1. 33
2. 38
3. 47
4. 52

- 2-10. When two ships are experiencing constant bearing decreasing range, what action must be taken?

1. The burdened vessel must turn to port
2. The burdened vessel must turn to starboard
3. Both vessel's must turn to port
4. Both vessel's must turn to starboard

- 2-11. When does a crossing situation occur?

1. When one ship approaches another from  $0^\circ$  to  $90^\circ$  relative
2. When one ship approaches another from  $0^\circ$  to  $112\ 1/2^\circ$  relative
3. When one ship approaches another from  $0^\circ$  to  $135^\circ$  relative
4. Any time two ships meet from any direction except dead astern

- 2-12. How is the term "length and breadth" defined?

1. A vessel's overall length and smallest beam
2. A vessel's overall length and draft
3. A vessel's overall length and greatest beam
4. A vessel's overall length and least draft

2-13. Which publication will indicate the harbor's demarcation lines?

1. 72 COLREGS
2. M 16672-2B
3. ATP 1 VOL
4. CG-69

2-14. When observing the International Rules, what is indicated by two short blasts?

1. I intend to alter course to port
2. I intend to alter course to starboard
3. I am altering course to port
4. I am altering course to starboard

2-15. A vessel agreeing to be overtaken should sound what whistle signal?

1. One prolonged and one short blast
2. One short and one prolonged blast
3. Two prolonged and two short blasts
4. One prolonged, one short, one prolonged, and one short blast

2-16. The International Rules do not specify a distance for sounding signals.

1. True
2. False

2-17. Which of the following is NOT a recognized distress signal?

1. Code November Charlie
2. Parachuted red flare
3. Square flag and ball
4. The national ensign flown upside down

2-18. To which Sun is apparent solar time measured?

1. True
2. Real
3. Fictional
4. Absolute

2-19. To which Sun is mean solar time measured?

1. Absolute
2. Real
3. Tabulated
4. Fictional

2-20. What type of time is kept by the ship's chronometers and clocks?

1. Mean solar
2. Apparent solar
3. Greenwich mean
4. Local mean

2-21. What type of clock keeps the most precise time yet developed?

1. Oscillator
2. Quartz
3. Atomic
4. Cesium

IN ANSWERING QUESTIONS 2-22 AND 2-23, REFER TO FIGURE 5-3 IN YOUR TEXT AS A REFERENCE POINT.

2-22. What time zone would you find 111°30'W?

1. K
2. T
3. U
4. W

2-23. What time zone would you find 147°30'E?

1. J
2. K
3. V
4. W

---

IN ANSWERING QUESTIONS 2-24 THROUGH 2-27, SELECT FROM COLUMN B THE TIME ZONE DESIGNATION THAT MATCHES THE TIME ZONE LETTER IN COLUMN A. RESPONSES WILL ONLY BE USED ONCE.

	<u>A. LETTER</u>	<u>B. DESIGNATION</u>
2-24.	M	1. +12
2-25.	T	2. -12
2-26.	W	3. +10
2-27.	Y	4. +7

---

2-28. What is the arc equivalent to 1 second of time?

1. 1'
2. 4"
3. 15'
4. 15"

- 2-29. What is the time equivalent to 1' of arc?
1. 1 sec
  2. 1 min
  3. 4 sec
  4. 15 sec
- 2-30. What is the arc equivalent of 16H 13M 53S?
1. 240° 27' 15"
  2. 240° 43' 30"
  3. 242° 15' 12"
  4. 242° 27' 15"
- 2-31. What is the time equivalent of 1° 11' 11"?
1. Oh 4m 44s
  2. Oh 4m 45s
  3. Oh 15m 44s
  4. Oh 15m 45s
- 2-32. When crossing the International Date Line, which time rule is correct?
1. Retard 1 day traveling east
  2. Retard 1 day traveling west
  3. Advance 12 hours traveling east
  4. Advance 12 hours traveling west
- 2-33. The cesium chronometer is the main source for keeping shipboard time.
1. True
  2. False
- 2-34. When are step adjustments applied to time signals?
1. December 31st only
  2. June 30th only
  3. September 7th
  4. December 31st and June 30th
- 2-35. What is the maximum error obtained when DUT is applied to GMT?
1. 0.1 sec
  2. 0.25 sec
  3. 0.50 sec
  4. 1.00 sec
- 2-36. When figuring time, which formula is correct?
1.  $DUT = GMT + UTC$
  2.  $UTC = GMT + DUT$
  3.  $GMT = UTC + DUT$
  4.  $GMT = UTC - DUT$
- 2-37. During the last 5 minutes of an hourly time tick, which second is NOT transmitted during the 57th minute?
1. 51st
  2. 52nd
  3. 55th
  4. 57th
- 2-38. During the last 5 minutes of an hourly time tick, the 29th second of each minute is NOT transmitted.
1. True
  2. False
- 2-39. Which of the following is not a time tick?
1. CHU (Ottawa, Can.)
  2. NWV (Ft. Collins, Col.)
  3. WWVT (Memphis, Tenn.)
  4. WWVH (Honolulu, Ha.)
- 2-40. How many megahertz are used to transmit time ticks?
1. 2.5
  2. 12.0
  3. 14.0
  4. 21.0
- 2-41. On 01 February 94, your chronometer read -1 min 14 sec, and on 28 February 94, your chronometer read -0 min 43 sec. What was the ADR?
1. -1.1
  2. +1.1
  3. +1.4
  4. -1.5
- 2-42. Which timepiece(s) is/are used to time celestial observations?
1. Stopwatch only
  2. Comparing watch only
  3. Stopwatch or comparing watch
  4. An accurate wrist watch
- 2-43. How is the celestial equator also referred?
1. The equinox
  2. The celestial meridian
  3. The celestial parallel
  4. The equinoctial

IN ANSWERING QUESTIONS 2-44 THROUGH 2-47, SELECT FROM COLUMN B THE DESCRIPTION THAT MATCHES THE TERM IN COLUMN A. RESPONSES WILL ONLY BE USED ONCE.

<u>A. TERMS</u>	<u>B. DESCRIPTIONS</u>
2-44. Celestial equator	1. Great circles that encircle the celestial sphere, as do meridians to longitude
2-45. Declination	2. Latitude
2-46. First point of Aries	3. Reference point for measuring declination
2-47. Hour circles	4. Reference point for measuring angles of stars and planets

IN ANSWERING QUESTIONS 2-48 THROUGH 2-50, SELECT FROM COLUMN B THE DESCRIPTION THAT MATCHES THE TERM IN COLUMN A. NOT ALL RESPONSES ARE USED.

<u>A. TERMS</u>	<u>B. DESCRIPTIONS</u>
2-48. GHA	1. The angular measurement of a celestial body measured eastward from Greenwich
2-49. LHA	2. The angular measurement of a celestial body measured westward from Greenwich
2-50. SHA	3. Hour angle of a star
	4. The observed meridian of the celestial body

- 2-51. With reference to the Celestial Coordinate System, which of the following facts is true?
1. The first point of Aries is the starting point for all celestial observations
  2. Source celestial bodies are motionless
  3. LHA associates all hour circles of a celestial body with the Greenwich meridian
  4. LHA of Aries will align with the Greenwich meridian

- 2-52. Which of the following planets is NOT used in navigation?
1. Neptune
  2. Jupiter
  3. Venus
  4. Saturn
- 2-53. How many navigational stars are listed in the Nautical Almanac?
1. 51
  2. 57
  3. 63
  4. 69
- 2-54. When figuring morning or evening star time, which formula is correct?
1. Add 30 minutes to sunset
  2. Add 45 minutes to sunset
  3. Subtract 45 minutes from sunset
  4. Subtract 30 minutes from sunset
- 2-55. What information must be known to enter H.O. 249?
1. Declination and LHA
  2. Declination and GHA
  3. Latitude and LHA
  4. Latitude and GHA
- 2-56. The Rude Starfinder uses how many transparent templates?
1. 8
  2. 10
  3. 12
  4. 15
- 2-57. What is the altitude wave range of a Rude Starfinder template?
1. 5 to 70
  2. 5 to 80
  3. 10 to 65
  4. 10 to 80
- 2-58. The only advantage of the Rude Starfinder is to select several stars for observation.
1. True
  2. False
- 2-59. What data must be known to use the Rude Starfinder?
1. Latitude only
  2. LHA only
  3. Latitude and declination
  4. Latitude and LHA

ASSIGNMENT 3

Textbook Assignment: "Celestial Observations and Sight Reduction Methods," chapter 9, pages 9-1 through 9-24.

- 3-1. Which of the following celestial bodies is/are NOT used to determine gyro error?
1. Sun only
  2. Stars
  3. Moon only
  4. Polaris and Sun
- 3-2. A minimum of how many azimuths of the Sun are shot when figuring gyrocompass error?
1. 5
  2. 2
  3. 3
  4. 4
- 3-3. Why take multiple observations when determining gyrocompass error by azimuth of the Sun?
1. To make sure the gyro is working properly
  2. To use the lowest gyro error obtained
  3. To use the highest gyro error obtained
  4. The average of all azimuth observations obtained gives a more accurate gyro error
- 3-4. What publication is used to figure the first half of an azimuth of the Sun?
1. Nautical Almanac
  2. Air Almanac
  3. H.O. Pub 229
  4. H.O. Pub 249
- 3-5. What is the GHA?
1.  $48^{\circ} 42.2'$
  2.  $63^{\circ} 41.0'$
  3.  $273^{\circ} 42.2'$
  4.  $288^{\circ} 42.8'$
- 3-6. What is the Total GHA?
1.  $68^{\circ} 17.4'$
  2.  $71^{\circ} 16.8'$
  3.  $74^{\circ} 15.8'$
  4.  $76^{\circ} 58.8'$
- 3-7. What is the LHA?
1.  $51^{\circ} 57.8'$
  2.  $52^{\circ} 16.8'$
  3.  $96^{\circ} 47.3'$
  4.  $98^{\circ} 08.1'$
- 3-8. What is the True Dec?
1. S  $19^{\circ} 21.9'$
  2. S  $19^{\circ} 22.5'$
  3. S  $19^{\circ} 21.9'$
  4. S  $19^{\circ} 23.1'$
- 3-9. What is the Tab Z?
1.  $128.7^{\circ}$
  2.  $129.0^{\circ}$
  3.  $129.4^{\circ}$
  4.  $129.9^{\circ}$
- 3-10. What is the (a) Dec Inc and (b) Z diff?
1. (a)  $-38$  (b)  $+7$
  2. (a)  $.35$  (b)  $-.7$
  3. (a)  $.38$  (b)  $+9$
  4. (a)  $.32$  (b)  $-.8$
- 3-11. What is the Dec Corr?
1.  $+.27$
  2.  $-.27$
  3.  $+.25$
  4.  $-.26$
- 3-12. What are the (a) Lat Inc and (b) Z diff?
1. (a)  $.98$  (b)  $+.2$
  2. (a)  $.97$  (b)  $+.2$
  3. (a)  $.96$  (b)  $-.2$
  4. (a)  $.95$  (b)  $-.2$
- 3-13. What is the Lat Corr?
1.  $+1.5$
  2.  $-1.5$
  3.  $+1.9$
  4.  $-1.9$

YOUR SHIP IS STEAMING IN THE NORTH ATLANTIC, AND YOU FIGURE GYROCOMPASS ERROR BY AZIMUTH OF THE SUN. THE DATE IS 18 NOVEMBER 1984, THE DR LATITUDE IS  $34^{\circ} 58'N$ , AND LONGITUDE IS  $22^{\circ} 18'W$ . THE ZONE TIME IS 14h 42m 19s, AND YOU OBSERVE THE SUN'S AZIMUTH AT  $227.8^{\circ}$ .

IN ANSWERING QUESTIONS 3-5 THROUGH 3-19, REFER TO FIGURES 9-1, 9-2, 9-3, AND 9-4 IN YOUR TEXT.

- 3-14. What is the (a) LHA Inc and (b) Z diff?
1. (a) .99 (b) -.5
  2. (a) .97 (b) +.7
  3. (a) .95 (b) +.8
  4. (a) .96 (b) -.8
- 3-15. What is the LHA Corr?
1. +.77
  2. -.77
  3. +.82
  4. -.82
- 3-16. What is the Total Corr?
1. +.1
  2. 0
  3. -.1
  4. -.3
- 3-17. What is the Exact Z?
1. 129.5°
  2. 129.4°
  3. 129.3°
  4. 129.1°
- 3-18. What is the Exact ZN?
1. 050.9°
  2. 221.7°
  3. 230.7°
  4. 230.9°
- 3-19. What is the Gyro Error?
1. 1.7°W
  2. 2.1°E
  3. 2.7°W
  4. 3.1°E
- 3-20. Polaris is always located within how many degrees of true north?
1. 1°
  2. 2°
  3. 3°
  4. 4°
- 3-21. At what maximum latitude can an Azimuth by Polaris be taken?
1. 60°
  2. 65°
  3. 70°
  4. 75°
- 3-22. What area is best for observing an Azimuth by Polaris?
1. North latitudes
  2. Lower northern latitudes
  3. Higher northern latitudes
  4. The Equator
- 3-23. How is Amplitude of the Sun defined?
1. The arc of the horizon between the prime vertical circle and the observed body
  2. The arc of the horizon between the prime horizontal circle and the observed body
  3. The arc of the horizon between the celestial horizon and the observed body
  4. the arc of the celestial horizon between the vertical circle and the observed body
- 3-24. The prime vertical circle may be true or magnetic depending on which east or west points are involved?
1. True
  2. False
- 3-25. How does the celestial horizon differ from the visible horizon?
1. They are perpendicular to each other
  2. The celestial horizon runs through the center of the Earth
  3. The celestial horizon and the Equator coincide
  4. The celestial horizon is perpendicular to the Earth's axis
- 3-26. When the center of the Sun is on the celestial horizon, what percentage of the Sun's diameter is above the visible horizon?
1. 25
  2. 33
  3. 67
  4. 75
- 3-27. When planets and stars are on the celestial horizon, how much of them is above the visible horizon?
1. Little less than one Sun diameter
  2. Little more than one Sun diameter
  3. Little more than two Sun diameters
  4. Little less than two Sun diameters
- 3-28. The amplitude of the body is setting and the declination is north. What is the (a) prefix and (b) suffix?
1. (a) East (b) south
  2. (a) West (b) north
  3. (a) North (b) east
  4. (a) South (b) west

- 3-29. What information must be known to figure an amplitude of the Sun?
1. DR latitude, DR longitude, declination, and true bearing to the Sun
  2. LMT, DR latitude declination, and true bearing to the Sun
  3. LMT, DR latitude DR longitude, declination, and true bearing to the Sun
  4. LMT, DR latitude, declination, and true bearing to the Sun

YOUR SHIP IS STEAMING IN THE NORTH ATLANTIC, AND YOU FIGURE AN AMPLITUDE. YOUR DR LATITUDE IS  $38^{\circ} 08.1'N$ . THE DECLINATION IS  $S 21^{\circ} 00.0'$ . THE SUN'S POSITION IS SETTING AND THE SUN'S TRUE BEARING  $245.2^{\circ}T$ .

IN ANSWERING QUESTIONS 3-30 THROUGH 3-34, REFER TO FIGURE 9-7 IN YOUR TEXT.

- 3-30. How is the amplitude labeled?

1. E  $27.1^{\circ} N$
2. W  $27.1^{\circ} S$
3. E  $27.7^{\circ} S$
4. W  $27.7^{\circ} N$

- 3-31. What is the azimuth?

1.  $062.9^{\circ}$
2.  $117.1^{\circ}$
3.  $242.9^{\circ}$
4.  $297.7^{\circ}$

- 3-32. What is the gyro error?

1.  $2.3^{\circ}W$
2.  $2.5^{\circ}W$
3.  $2.7^{\circ}E$
4.  $3.1^{\circ}E$

- 3-33. The ship's latitude is  $37^{\circ} 00.8'N$  and the declination is  $S 20.0^{\circ}$ . What is the azimuth?

1.  $25.0^{\circ}$
2.  $25.3^{\circ}$
3.  $25.4^{\circ}$
4.  $25.7^{\circ}$

- 3-34. The ship's latitude is  $39^{\circ} 35'0 N$  and the declination is  $S 22^{\circ} 48'$ . What is the azimuth?

1.  $29.4^{\circ}$
2.  $29.5^{\circ}$
3.  $30.2^{\circ}$
4.  $30.4^{\circ}$

- 3-35. Your ship is on the Equator, and the declination is  $N 18^{\circ} 51'$ . What is the azimuth?

1.  $18.5^{\circ}$
2.  $18.8^{\circ}$
3.  $18.9^{\circ}$
4.  $19.0^{\circ}$

- 3-36. Which of the following rules for figuring an amplitude is expressed correctly?

1. Setting Sun with north declination, add amplitude to  $090^{\circ}$
2. Setting Sun with south declination, subtract amplitude from  $090^{\circ}$
3. Setting Sun with north declination, add amplitude to  $270^{\circ}$
4. Setting Sun with south declination, subtract amplitude from  $270^{\circ}$

- 3-37. What is the correct formula for figuring amplitude in south latitude, with north declination, and the Sun is rising?

1.  $090^{\circ} - \text{amplitude}$
2.  $090^{\circ} + \text{amplitude}$
3.  $279^{\circ} - \text{amplitude}$
4.  $270^{\circ} + \text{amplitude}$

- 3-38. When using Bowditch (tables), volume II, in addition to table 27, when is table 28 used to figure amplitude?

1. When the ship is in southern latitudes
2. When the ship is on the Equator
3. If the body is observed when its center is on the celestial fix? horizon
4. If the body is observed when its center is on the visible horizon

- 3-39. What is the most accurate method of obtaining a celestial fix?

1. Take many sightings in a short period of time
2. Take a few sightings in a short period of time
3. Take as many sightings as you can in 15 minutes
4. Take 6 or more sightings in 15-30 minutes



IN ANSWERING QUESTIONS 3-46 THROUGH 3-49, SELECT FROM COLUMN B THE DESCRIPTION THAT MATCHES THE CORRECTION IN COLUMN A. RESPONSES WILL ONLY BE USED ONCE.

A. CORRECTION    B. DESCRIPTION

- 3-40. What type of fix is obtained by one LOP of a heavenly body?
1. AP
  2. EP
  3. DR
  4. Celestial
- 3-41. How is the star's altitude from the assumed position referred?
1. Ha
  2. Ho
  3. Hc
  4. Hz
- 3-42. Which of the following is the sextant altitude of a star?
1. Ha
  2. Ho
  3. Hc
  4. Hs
- 3-43. What is obtained when sextant altitude is corrected?
1. Ho
  2. Ha
  3. Hc
  4. Hs
- 3-44. When plotting a star's LOP, the abbreviation HoMoTo means the altitude intercept should be measured from the EP toward the star.
1. True
  2. False
- 3-45. When you are observing the Sun, what is the next step to carry out after you have trained the line of sight on the point of the horizon just below the Sun?
1. Raise the sextant until the line of sight touches the lower limb of the Sun
  2. Swing the arc about the line of sight
  3. Move the index arm until the Sun appears in the mirror
  4. Move the micrometer drum to bring the direct and the reflected horizons in line

- |                    |   |
|--------------------|---|
| 3-46. Refraction   | 1. Difference between the celestial and visible horizons  |
| 3-47. Dip          | 2. Deviation of rays of light from a straight line Earth's atmosphere   |
| 3-48. Parallax     | 3. Proximity of bodies of the solar system to the Earth, resulting in a difference in altitudes measured from the surface and the center of the Earth         |
| 3-49. Semidiameter | 4. Results from the nearness of bodies of the solar system. Makes it necessary to consider the observed bodies as appreciable size instead of points of light |

- 
- 3-50. When does maximum refraction occur?
1. When a body is on the horizon amounting to between 24 and 29 minutes of arc
  2. When a body is on the horizon amounting to between 34 and 39 minutes of arc
  3. When a body is on the horizon amounting to between 18 and 27 minutes of arc
  4. When a body is on the horizon amounting to between 35 and 45 minutes of arc
- 3-51. Refraction varies with atmospheric conditions. At what point should observations be regarded as suspicious?
1. Below 5°
  2. Below 10°
  3. Above 15°
  4. At 0°

- 3-52. Dip corrections are always subtracted.
1. True
  2. False
- 3-53. Failure to correct for dip at a height of 10 feet will result in how much error?
1. 1 mi
  2. 3 mi
  3. 5 mi
  4. 10 mi
- 3-54. How is parallax always applied?
1. Multiplied
  2. Divided
  3. Added
  4. Subtracted
- 3-55. Which of the following describes parallax in relation to celestial bodies?
1. Parallax of the Sun is small
  2. Parallax of the planets is smaller
  3. Parallax of stars is tiny
  4. All of the above
- 3-56. If the upper limb of a celestial body is observed, how is the semidiameter applied?
1. Added
  2. Multiplied
  3. Divided
  4. Subtracted
- 3-57. What is the usual semidiameter correction for the Sun and Moon?
1. 10 min
  2. 15 min
  3. 16 min
  4. 20 min
- 3-58. The Nautical Almanac contains some tables that combine refraction, parallax, and semidiameter.
1. True
  2. False
- 3-59. Which strip form is used to reduce star sights?
1. OPNAV 3530/30 H.O. 229 Nautical Almanac
  2. OPNAV 3530/30 H.O. 249 Nautical Almanac
  3. OPNAV 3030/35 H.O. 229 Nautical Almanac
  4. OPNAV 3530/35 H.O. 229, H.O. 249
- 3-60. The dip is -2.3 and the IC correction is +2.5. What is the total sextant correction?
1. +4.8
  2. -4.8
  3. +0.2
  4. -0.2
- 3-61. The HA is  $26^{\circ} 47.8'$ , and the altitude correction is  $23.9'$ . What is the Ho?
1.  $26^{\circ} 11.7'$
  2.  $26^{\circ} 23.9'$
  3.  $26^{\circ} 71.7'$
  4.  $27^{\circ} 11.7'$

ASSIGNMENT 4

Textbook Assignment: "Celestial Observations and Sight Reduction Methods" continued, chapter 9, pages 9-15 through 9-41.

IN ANSWERING QUESTIONS 4-1 THROUGH 4-9 REFER TO FIGURES 4-A THROUGH 4-E, LOCATED AT THE END OF THIS ASSIGNMENT, TO FIGURE A SUNLINE. THE FOLLOWING INFORMATION IS GIVEN.

DATE: 1 MARCH 1984  
 DR LATITUDE: 32°14.0'N  
 DR LONGITUDE: 18°54.0'W  
 GMT: 11-27-30  
 HEIGHT OF EYE: 32 FT  
 ON THE ARC: 1.0'  
 hs: 41°31.3

- 4-8. What is the intercept?
1. 22.4 miles away
  2. 22.4 miles towards
  3. 16.2 miles away
  4. 16.2 miles towards

- 4-9. What is the Zn?
1. 139.2°
  2. 139.5°
  3. 138.4°
  4. 140.2°

UPON FIGURING A SUNLINE YOUR DR LATITUDE IS 37°14.3'N, DECLINATION IS 09°29.4', AND THE LHA IS 300°.

IN ANSWERING QUESTIONS 4-10 AND 4-11 REFER TO FIGURES 9-10 AND 9-11 IN YOUR TEXT.

- 4-10. What is the d?
1. 35.3
  2. 35.4
  3. 36.4
  4. 36.8

- 4-11. What is the HC?
1. 28°14.6'
  2. 28°15.7'
  3. 29°08.4'
  4. 29°14.7'

4-12. When plotting a sunline (LOP) which longitude is used to plot the AP on the plotting sheet?

1. The DR longitude
2. The actual longitude
3. The assumed longitude
4. The computed longitude

- 4-1. What is the IC correction?
1. 0
  2. +1.0
  3. -1.0
  4. -2.0
- 4-2. What is the altitude correction?
1. +14.9
  2. -14.9
  3. +15.2
  4. -15.2
- 4-3. What is the Ho?
1. 41°09.6'
  2. 41°24.8'
  3. 41°36.5'
  4. 41°40.0'
- 4-4. What is the total GHA?
1. 331°00.0'
  2. 335°29.2'
  3. 341°54.7'
  4. 348°47.2'
- 4-5. What is the LHA?
1. 324°
  2. 330°
  3. 346°
  4. 356°
- 4-6. What is the d#?
1. - .5
  2. + .5
  3. -1.0
  4. +1.0
- 4-7. What is the total declination interpolation correction?
1. 10.7'
  2. 20.5'
  3. 23.0'
  4. 26.3'

IN ANSWERING QUESTIONS 4-13 THROUGH 4-17, REFER TO FIGURE 4-F, LOCATED AT THE END OF THIS ASSIGNMENT. FIGURE 4-F PERTAINS TO A CELESTIAL FIX OBTAINED BY THE INTERSECTION OF THREE LINES OF POSITIONS. FIGURE 4-F SHOWS HOW (UNDER IDEAL CONDITIONS) A FIX CAN BE OBTAINED DURING THE DAYTIME BY OBSERVING THE SUN, MOON, AND VENUS. THE SIZE OF THE RESULTING TRIANGLE HAS BEEN ENLARGED IN RELATION TO THE REST OF THE DIAGRAM STRICTLY FOR ILLUSTRATIVE PURPOSES.

- 4-13. Points A, B, and C in figure 4-F represent
1. known positions
  2. assumed positions
  3. altitude intercepts
  4. azimuth intercepts
- 4-14. Which line in figure 4-F represents the true azimuth of a celestial body?
1. B-D
  2. E-G
  3. H-I
  4. S-T
- 4-15. An altitude intercept is represented in figure 4-F by line
1. A-N
  2. C-H
  3. K-J
  4. S-T
- 4-16. An advanced line of position is represented in figure 4-F by lines
1. B-D and C-H
  2. D-F and H-I
  3. E-G and L-M
  4. K-J and S-T
- 4-17. In figure 4-F, the 1530 fix should be indicated as being at point
1. W
  2. X
  3. Y
  4. Z
- 4-18. Which, if any of the LOP, if any, did not need to be advanced?
1. Moon
  2. Sirius
  3. Venus
  4. None of the above

- 4-19. What is the difference between figuring an LOP of the sun, and the LOP of a star?
1. Subtract SHA from LHA
  2. Add SHA to LHA
  3. Subtract SHA from LHA
  4. Add SHA to GHA
- 4-20. When figuring planets, which correction(s) is/are applied to GHA?
1. v only
  2. d only
  3. r factor
  4. v and d
- 4-21. When figuring the Moon, how is the V correction applied?
1. Always added
  2. Always subtracted
  3. Added in south latitudes only
  4. Added in north latitudes only

IN ANSWERING QUESTIONS 4-22 THROUGH 4-34 REFER TO FIGURE 4-C THROUGH 4-E, 4-H AND 4-I, LOCATED AT THE END OF THIS ASSIGNMENT. THE FOLLOWING INFORMATION IS GIVEN.

Body:	ANTARES
DATE:	14 January 1990
DR LATITUDE:	36°09.1'N
DR LONGITUDE:	143°27.9E
GMT:	21 18 38
HEIGHT OF EYE:	80 FT
IC:	+3.0'
hs:	21°35.3

- 4-22. What is the sum of the IC and Dip correction?
1. -5.7'
  2. +5.7'
  3. -11.7'
  4. +11.7'
- 4-23. What is the Ha?
1. 21° 23.6'
  2. 21° 29.6'
  3. 21° 41.0'
  4. 21° 47.0'
- 4-24. What is the altitude correction?
1. - 2.4
  2. + 2.8
  3. +15.0
  4. -15.2
- 4-25. What is the Ho?
1. 21° 18.0'
  2. 21° 27.2'
  3. 21° 29.6'
  4. 21° 30.5'

IN ANSWERING QUESTIONS 4-35 THROUGH 4-44, REDUCING SIGHTS USING H.O. 249, REFER TO FIGURES 9-17, 9-18, AND 9-19 IN YOUR TEXT. THE FOLLOWING INFORMATION IS GIVEN.

DATE: 30 March 1985  
 LATITUDE: 37° 01.4'N  
 LONGITUDE: 27° 09.9'W  
 hs: 49° 41.0' Altair  
 HEIGHT OF EYE: 40 Feet  
 GMT: 07 00 00  
 IC: + .7

4-26. What is the total GHA?

1. 73" 44.0'
2. 112° 48.1'
3. 147° 32.8'
4. 186° 32.1'

4-27. What is the assumed longitude?

1. 143° 27.91'
2. 143° 32.1'
3. 143° 37.9'
4. 144° 00.0'

4-28. What is the true Dec?

1. S 26° 18.0'
2. S 26° 21.7'
3. S 26° 24.7'
4. S 26° 33.8'

4-29. What is the Dec INC/d?

1. 18.0 and -39.6'
2. 21.7 and -47.2'
3. 24.7 and +54.0'
4. 33.8 and +54.0'

4-30. What is the total corr?

1. +20.6'
2. -20.6'
3. -19.0'
4. -22.2'

4-31. What is the Hc (Tab)?

1. 21° 24.3'
2. 21° 41.8'
3. 21° 45.5'
4. 21° 50.5'

4-32. What is the computed Hc?

1. 18.0'
2. 28.3'
3. 29.6'
4. 30.5'

4-33. What is the a?

1. 1.3 A
2. 1.3 T
3. 1.6 A
4. 1.8 T

4-34. What is the Zn?

1. 154.0
2. 154.5
3. 205.9
4. 205.8

4-35. What is the dip?

1. -5.4
2. -5.7
3. =6.1
4. -6.3

4-36. What is the Ha?

1. 49° 32.8'
2. 49° 35.6'
3. 49° 53.6'
4. 49° 58.7'

4-37. What is the altitude correction?

1. -.4
2. -.6
3. -.7
4. -.8

4-38. What is the Ho?

1. 49° 23.8'
2. 49° 27.8'
3. 49° 32.9'
4. 49° 34.3'

4-39. What is the total GHA?

1. 291° 36.7'
2. 291° 53.7'
3. 292° 36.7'
4. 292° 46.3'

4-40. What is the LHA?

1. 264°
2. 265°
3. 267°
4. 268°

4-41. What is the Hc?

1. 49° 21.0
2. 49° 23.0
3. 49° 24.0
4. 49° 27.0

4-42. What is the a factor?

1. 10.4 T
2. 10.4 A
3. 12.6 T
4. 12.6 A

4-43. What is the Zn?

1. 120
2. 122
3. 124
4. 126

4-44. What is the assumed longitude?

1.  $27^{\circ} 09.9'$
2.  $27^{\circ} 15.4'$
3.  $27^{\circ} 36.7'$
4.  $27^{\circ} 46.7'$

IN ANSWERING QUESTIONS 4-45 THROUGH 4-52,  
REFER TO FIGURES 4-C, 4-G, AND 4-H,  
LOCATED AT THE END OF THIS ASSIGNMENT.  
THE FOLLOWING INFORMATION IS GIVEN TO  
SOLVE THE LOCAL APPARENT NOON.

DATE: 1 AUGUST 1984  
DR LATITUDE:  $32^{\circ}20.1N$   
DR LONGITUDE:  $17^{\circ}50.0W$   
ZT LAN OBSERVED: 1218  
IC: 1.5  
hs:  $75^{\circ}20.1'$   
HEIGHT OF EYE: 60 FT

4-45. What is the standard meridian?

1.  $0^{\circ}$
2.  $7 1/2^{\circ}$
3.  $15^{\circ}$
4.  $22 1/2^{\circ}$

4-46. What is the local mean time of meridian passage?

1. 1206
2. 1218
3. 1230
4. 1300

4-47. What is the zone description?

1. 0
2. +1
3. -1
4. +2

4-48. What is the d correction?

1. +.2
2. -.2
3. +.6
4. -.6

4-49. What is the IC correction?

1. 0
2. (+)1.5
3. (-)1.5
4. +3.0

4-50. What is the Ha?

1.  $75^{\circ}14.1'$
2.  $75^{\circ}18.6'$
3.  $75^{\circ}21.6'$
4.  $75^{\circ}30.0'$

4-51. What is the Ho?

1.  $75^{\circ}14.1'$
2.  $75^{\circ}18.6'$
3.  $75^{\circ}21.6'$
4.  $75^{\circ}29.8'$

4-52. What is the latitude by LAN?

1.  $32^{\circ}20.0'$
2.  $32^{\circ}21.0'$
3.  $32^{\circ}21.6'$
4.  $32^{\circ}24.2'$

4-53. What method(s) is/are used in taking sights of LAN?

1. Maximum altitude only
2. Numerous sights only
3. Altitude suspension
4. Maximum altitude and numerous sights

4-54. Maximum altitude is recommended because of its adaptability to various conditions, and because it develops an insight into how altitude varies near LAN?

1. True
2. False

4-55. When observing LAN, how many minutes prior to the computed time should the observer commence taking sights?

1. 5
2. 10
3. 15
4. 20

4-56. If LAN is accurate, what should the maximum latitude error be?

1. 0.25'
2. 0.50'
3. 1.0'
4. 1.5'

1984 MARCH 1, 2, 3 (THURS., FRI., SAT.)

51

G.M.T	SUN		MOON				Lat.	Twilight		Sunrise	Moonrise				
	G.M.A.	Dec	G.M.A.	V	Dec	d		M.P.	Naut.		Civil	Moonrise			
												1	2	3	4
1 00	176 53.4	S 7 35.7	193 39.8	13.6	S18 49.1	9.0	54.0	N 72	05 04	06 22	07 31	10 18	09 12	08 38	08 12
01	191 53.5	34.8	208 12.4	13.7	18 40.1	8.9	54.0	N 70	05 10	06 20	07 22	09 22	08 47	08 25	08 06
02	206 53.6	33.8	222 45.1	13.8	18 31.2	9.1	54.0	68	05 14	06 19	07 15	08 47	08 28	08 14	08 02
03	221 53.8	32.9	237 17.9	13.8	18 22.1	9.2	54.0	66	05 18	06 17	07 09	08 23	08 13	08 05	07 58
04	236 53.9	31.9	251 50.7	13.9	18 12.9	9.2	54.0	64	05 21	06 16	07 03	08 03	08 01	07 58	07 55
05	251 54.0	31.0	266 23.6	13.9	18 03.7	9.3	54.0	62	05 23	06 15	06 59	07 47	07 50	07 51	07 52
06	266 54.1	S 7 30.0	280 56.5	14.0	S17 54.4	9.4	54.0	60	05 25	06 13	06 55	07 34	07 41	07 46	07 50
07	281 54.2	29.1	295 29.5	14.0	17 45.0	9.4	54.0	N 58	05 27	06 12	06 52	07 22	07 33	07 41	07 48
08	296 54.4	28.1	310 02.5	14.1	17 35.6	9.5	54.0	56	05 29	06 11	06 49	07 12	07 26	07 36	07 46
09	311 54.5	27.2	324 35.6	14.1	17 26.1	9.6	54.0	54	05 30	06 11	06 46	07 03	07 19	07 32	07 44
10	326 54.6	26.2	339 08.7	14.2	17 16.5	9.7	54.0	52	05 31	06 10	06 43	06 55	07 14	07 29	07 42
11	341 54.7	25.3	353 41.9	14.3	17 06.8	9.7	54.0	50	05 31	06 09	06 41	06 48	07 08	07 25	07 41
12	356 54.9	S 7 24.3	8 15.2	14.3	S16 57.1	9.8	54.0	45	05 33	06 07	06 36	06 33	06 57	07 18	07 38
13	11 55.0	23.3	22 48.5	14.3	16 47.3	9.8	54.0	N 40	05 33	06 05	06 32	06 20	06 48	07 12	07 35
14	26 55.1	22.4	37 21.8	14.4	16 37.5	10.0	53.9	35	05 33	06 03	06 28	06 09	06 39	07 07	07 33
15	41 55.2	21.4	51 55.2	14.5	16 27.5	10.0	53.9	30	05 33	06 01	06 25	06 00	06 32	07 02	07 31
16	56 55.3	20.5	66 28.7	14.5	16 17.5	10.0	53.9	20	05 31	05 57	06 19	05 43	06 20	06 54	07 27
17	71 55.5	19.5	81 02.2	14.6	16 07.5	10.1	53.9	N 10	05 28	05 53	06 14	05 29	06 09	06 47	07 24
18	86 55.6	S 7 18.6	95 35.8	14.6	S15 57.4	10.2	53.9	0	05 24	05 48	06 09	05 15	05 59	06 41	07 21
19	101 55.7	17.6	110 09.4	14.6	15 47.2	10.3	53.9	S 10	05 18	05 43	06 04	05 02	05 49	06 34	07 18
20	116 55.8	16.7	124 43.0	14.8	15 36.9	10.3	53.9	20	05 10	05 36	05 58	04 47	05 38	06 27	07 15
21	131 56.0	15.7	139 16.8	14.7	15 26.6	10.4	53.9	30	04 59	05 27	05 52	04 30	05 25	06 19	07 11
22	146 56.1	14.8	153 50.5	14.8	15 16.2	10.4	53.9	35	04 52	05 22	05 48	04 21	05 18	06 14	07 09
23	161 56.2	13.8	168 24.3	14.9	15 05.8	10.5	53.9	40	04 43	05 16	05 44	04 09	05 09	06 08	07 07
24	176 56.3	S 7 12.9	182 58.2	14.9	S14 55.3	10.6	53.9	45	04 32	05 09	05 39	03 56	04 59	06 02	07 04
25	191 56.5	11.9	197 32.1	14.9	14 44.7	10.6	53.9	S 50	04 19	04 59	05 33	03 40	04 48	05 55	07 01
26	206 56.6	11.0	212 06.0	15.0	14 34.1	10.7	53.9	52	04 12	04 55	05 30	03 32	04 42	05 51	07 00
27	221 56.7	10.0	226 40.0	15.1	14 23.4	10.7	53.9	54	04 04	04 50	05 27	03 24	04 36	05 47	06 58
28	236 56.9	09.0	241 14.1	15.1	14 12.7	10.8	53.9	56	03 56	04 44	05 23	03 14	04 29	05 43	06 56
29	251 57.0	08.1	255 48.2	15.1	14 01.9	10.8	53.9	58	03 46	04 38	05 20	03 03	04 21	05 38	06 54
30	266 57.1	S 7 07.1	270 22.3	15.2	S13 51.1	10.9	53.9	S 60	03 34	04 31	05 15	02 51	04 12	05 33	06 52
31	281 57.2	06.2	284 56.5	15.2	13 40.2	11.0	53.9								
32	296 57.4	05.2	299 30.7	15.3	13 29.2	11.0	53.9	Lat.	Sunset	Twilight		Moonset			
33	311 57.5	04.3	314 05.0	15.3	13 18.2	11.0	53.9			Civil	Naut.	1	2	3	4
34	326 57.6	03.3	328 39.3	15.4	13 07.2	11.1	53.9								
35	341 57.7	02.4	343 13.7	15.4	12 56.1	11.2	53.9	N 72	16 56	18 05	19 23	12 52	15 28	17 29	19 20
36	356 57.9	S 7 01.4	357 48.1	15.4	S12 44.9	11.2	53.9	N 70	17 04	18 06	19 17	13 47	15 51	17 39	19 23
37	11 58.0	7 00.4	12 22.5	15.5	12 33.7	11.2	53.9	68	17 11	18 08	19 12	14 20	16 08	17 48	19 25
38	26 58.1	6 59.5	26 57.0	15.5	12 22.5	11.3	53.9	66	17 17	18 09	19 08	14 44	16 22	17 55	19 26
39	41 58.3	6 58.5	41 31.5	15.6	12 11.2	11.4	53.9	64	17 22	18 10	19 05	15 02	16 33	18 01	19 27
40	56 58.4	6 57.6	56 06.1	15.6	11 59.8	11.4	53.9	62	17 27	18 11	19 02	15 17	16 43	18 06	19 29
41	71 58.5	6 56.6	70 40.7	15.6	11 48.4	11.4	53.9	60	17 30	18 12	19 00	15 30	16 51	18 11	19 30
42	86 58.6	S 6 55.7	85 15.3	15.7	S11 37.0	11.5	53.9	N 58	17 34	18 13	18 59	15 41	16 58	18 15	19 30
43	101 58.8	6 54.7	99 50.0	15.7	11 25.5	11.6	53.9	56	17 37	18 14	18 57	15 50	17 05	18 18	19 31
44	116 58.9	6 53.7	114 24.7	15.7	11 13.9	11.6	53.9	54	17 39	18 15	18 56	15 58	17 10	18 21	19 32
45	131 59.0	6 52.8	128 59.4	15.8	11 02.4	11.7	53.9	52	17 42	18 16	18 55	16 06	17 15	18 24	19 33
46	146 59.2	6 51.8	143 34.2	15.8	10 50.7	11.6	53.9	50	17 44	18 16	18 54	16 13	17 20	18 27	19 33
47	161 59.3	6 50.9	158 09.0	15.9	10 39.1	11.7	53.9	45	17 49	18 18	18 52	16 27	17 30	18 32	19 34
48	176 59.4	S 6 49.9	172 43.9	15.8	S10 27.4	11.8	53.9	N 40	17 53	18 20	18 52	16 38	17 38	18 37	19 35
49	191 59.6	6 48.9	187 18.7	16.0	10 15.6	11.7	53.9	35	17 57	18 22	18 51	16 48	17 45	18 41	19 36
50	206 59.7	6 48.0	201 53.7	15.9	10 03.9	11.9	53.9	30	18 00	18 24	18 52	16 57	17 51	18 44	19 37
51	221 59.8	6 47.0	216 28.6	16.0	9 52.0	11.8	53.9	20	18 06	18 28	18 53	17 12	18 01	18 50	19 38
52	236 59.9	6 46.1	231 03.6	16.0	9 40.2	11.9	53.9	N 10	18 11	18 32	18 56	17 25	18 11	18 55	19 39
53	252 00.1	6 45.1	245 38.6	16.0	9 28.3	12.0	53.9	0	18 15	18 36	19 00	17 37	18 19	19 00	19 40
54	267 00.2	S 6 44.2	260 13.6	16.1	S 9 16.3	11.9	53.9	S 10	18 20	18 42	19 06	17 48	18 28	19 05	19 42
55	282 00.3	6 43.2	274 48.7	16.1	9 04.4	12.1	53.9	20	18 26	18 48	19 14	18 01	18 37	19 10	19 43
56	297 00.5	6 42.2	289 23.8	16.1	8 52.3	12.0	53.9	30	18 32	18 56	19 25	18 16	18 47	19 16	19 44
57	312 00.6	6 41.3	303 58.9	16.1	8 40.3	12.1	54.0	35	18 36	19 01	19 32	18 24	18 53	19 19	19 45
58	327 00.7	6 40.3	318 34.0	16.2	8 28.2	12.1	54.0	40	18 40	19 07	19 40	18 33	18 59	19 23	19 45
59	342 00.9	6 39.4	333 09.2	16.2	8 16.1	12.1	54.0	45	18 45	19 15	19 51	18 44	19 07	19 27	19 46
60	357 01.0	S 6 38.4	347 44.4	16.2	S 8 04.0	12.2	54.0	S 50	18 51	19 24	20 04	18 57	19 16	19 32	19 47
61	12 01.1	6 37.4	2 19.6	16.3	7 51.8	12.2	54.0	52	18 53	19 28	20 11	19 04	19 20	19 35	19 48
62	27 01.3	6 36.5	16 54.9	16.2	7 39.6	12.3	54.0	54	18 56	19 33	20 18	19 10	19 25	19 37	19 48
63	42 01.4	6 35.5	31 30.1	16.3	7 27.3	12.2	54.0	56	19 00	19 38	20 27	19 18	19 30	19 40	19 49
64	57 01.5	6 34.5	46 05.4	16.3	7 15.1	12.3	54.0	58	19 03	19 44	20 36	19 26	19 36	19 43	19 49
65	72 01.7	6 33.6	60 40.7	16.4	7 02.8	12.3	54.0	S 60	19 07	19 51	20 48	19 36	19 42	19 46	19 50
66	87 01.8	S 6 32.6	75 16.1	16.3	S 6 50.5	12.4	54.0								
67	102 01.9	6 31.7	89 51.4	16.4											

26 <sup>m</sup>	SUN PLANETS	ARIES	MOON	v or Corr <sup>n</sup>		v or Corr <sup>n</sup>		v or Corr <sup>n</sup>		27 <sup>m</sup>	SUN PLANETS	ARIES	MOON	v or Corr <sup>n</sup>		v or Corr <sup>n</sup>		v or Corr <sup>n</sup>	
				d	'	d	'	d	'					d	'	d	'	d	'
00	6 300	6 31.1	6 12.2	0.0	00	6.0	2.7	12.0	5.3	00	6 450	6 46.1	6 26.6	0.0	00	6.0	2.8	12.0	5.5
01	6 303	6 31.3	6 12.5	0.1	00	6.1	2.7	12.1	5.3	01	6 453	6 46.4	6 26.8	0.1	00	6.1	2.8	12.1	5.5
02	6 305	6 31.6	6 12.7	0.2	01	6.2	2.7	12.2	5.4	02	6 455	6 46.6	6 27.0	0.2	01	6.2	2.8	12.2	5.6
03	6 308	6 31.8	6 12.9	0.3	01	6.3	2.8	12.3	5.4	03	6 458	6 46.9	6 27.3	0.3	01	6.3	2.9	12.3	5.6
04	6 31.0	6 32.1	6 13.2	0.4	02	6.4	2.8	12.4	5.5	04	6 46.0	6 47.1	6 27.5	0.4	02	6.4	2.9	12.4	5.7
05	6 31.3	6 32.3	6 13.4	0.5	02	6.5	2.9	12.5	5.5	05	6 46.3	6 47.4	6 27.7	0.5	02	6.5	3.0	12.5	5.7
06	6 31.5	6 32.6	6 13.7	0.6	03	6.6	2.9	12.6	5.6	06	6 46.5	6 47.6	6 28.0	0.6	03	6.6	3.0	12.6	5.8
07	6 31.8	6 32.8	6 13.9	0.7	03	6.7	3.0	12.7	5.6	07	6 46.8	6 47.9	6 28.2	0.7	03	6.7	3.1	12.7	5.8
08	6 32.0	6 33.1	6 14.1	0.8	04	6.8	3.0	12.8	5.7	08	6 47.0	6 48.1	6 28.5	0.8	04	6.8	3.1	12.8	5.9
09	6 32.3	6 33.3	6 14.4	0.9	04	6.9	3.0	12.9	5.7	09	6 47.3	6 48.4	6 28.7	0.9	04	6.9	3.2	12.9	5.9
10	6 32.5	6 33.6	6 14.6	1.0	04	7.0	3.1	13.0	5.7	10	6 47.5	6 48.6	6 28.9	1.0	05	7.0	3.2	13.0	6.0
11	6 32.8	6 33.8	6 14.9	1.1	05	7.1	3.1	13.1	5.8	11	6 47.8	6 48.9	6 29.2	1.1	05	7.1	3.3	13.1	6.0
12	6 33.0	6 34.1	6 15.1	1.2	05	7.2	3.2	13.2	5.8	12	6 48.0	6 49.1	6 29.4	1.2	06	7.2	3.3	13.2	6.1
13	6 33.3	6 34.3	6 15.3	1.3	06	7.3	3.2	13.3	5.9	13	6 48.3	6 49.4	6 29.7	1.3	06	7.3	3.3	13.3	6.1
14	6 33.5	6 34.6	6 15.6	1.4	06	7.4	3.3	13.4	5.9	14	6 48.5	6 49.6	6 29.9	1.4	06	7.4	3.4	13.4	6.1
15	6 33.8	6 34.8	6 15.8	1.5	07	7.5	3.3	13.5	6.0	15	6 48.8	6 49.9	6 30.1	1.5	07	7.5	3.4	13.5	6.2
16	6 34.0	6 35.1	6 16.1	1.6	07	7.6	3.4	13.6	6.0	16	6 49.0	6 50.1	6 30.4	1.6	07	7.6	3.5	13.6	6.2
17	6 34.3	6 35.3	6 16.3	1.7	08	7.7	3.4	13.7	6.1	17	6 49.3	6 50.4	6 30.6	1.7	08	7.7	3.5	13.7	6.3
18	6 34.5	6 35.6	6 16.5	1.8	08	7.8	3.4	13.8	6.1	18	6 49.5	6 50.6	6 30.8	1.8	08	7.8	3.6	13.8	6.3
19	6 34.8	6 35.8	6 16.8	1.9	08	7.9	3.5	13.9	6.1	19	6 49.8	6 50.9	6 31.1	1.9	09	7.9	3.6	13.9	6.4
20	6 35.0	6 36.1	6 17.0	2.0	09	8.0	3.5	14.0	6.2	20	6 50.0	6 51.1	6 31.3	2.0	09	8.0	3.7	14.0	6.4
21	6 35.3	6 36.3	6 17.2	2.1	09	8.1	3.6	14.1	6.2	21	6 50.3	6 51.4	6 31.6	2.1	1.0	8.1	3.7	14.1	6.5
22	6 35.5	6 36.6	6 17.5	2.2	1.0	8.2	3.6	14.2	6.3	22	6 50.5	6 51.6	6 31.8	2.2	1.0	8.2	3.8	14.2	6.5
23	6 35.8	6 36.8	6 17.7	2.3	1.0	8.3	3.7	14.3	6.3	23	6 50.8	6 51.9	6 32.0	2.3	1.1	8.3	3.8	14.3	6.6
24	6 36.0	6 37.1	6 18.0	2.4	1.1	8.4	3.7	14.4	6.4	24	6 51.0	6 52.1	6 32.3	2.4	1.1	8.4	3.9	14.4	6.6
25	6 36.3	6 37.3	6 18.2	2.5	1.1	8.5	3.8	14.5	6.4	25	6 51.3	6 52.4	6 32.5	2.5	1.1	8.5	3.9	14.5	6.6
26	6 36.5	6 37.6	6 18.4	2.6	1.1	8.6	3.8	14.6	6.4	26	6 51.5	6 52.6	6 32.8	2.6	1.2	8.6	3.9	14.6	6.7
27	6 36.8	6 37.8	6 18.7	2.7	1.2	8.7	3.8	14.7	6.5	27	6 51.8	6 52.9	6 33.0	2.7	1.2	8.7	4.0	14.7	6.7
28	6 37.0	6 38.1	6 18.9	2.8	1.2	8.8	3.9	14.8	6.5	28	6 52.0	6 53.1	6 33.2	2.8	1.3	8.8	4.0	14.8	6.8
29	6 37.3	6 38.3	6 19.2	2.9	1.3	8.9	3.9	14.9	6.6	29	6 52.3	6 53.4	6 33.5	2.9	1.3	8.9	4.1	14.9	6.8
30	6 37.5	6 38.6	6 19.4	3.0	1.3	9.0	4.0	15.0	6.6	30	6 52.5	6 53.6	6 33.7	3.0	1.4	9.0	4.1	15.0	6.9
31	6 37.8	6 38.8	6 19.6	3.1	1.4	9.1	4.0	15.1	6.7	31	6 52.8	6 53.9	6 33.9	3.1	1.4	9.1	4.2	15.1	6.9
32	6 38.0	6 39.1	6 19.9	3.2	1.4	9.2	4.1	15.2	6.7	32	6 53.0	6 54.1	6 34.2	3.2	1.5	9.2	4.2	15.2	7.0
33	6 38.3	6 39.3	6 20.1	3.3	1.5	9.3	4.1	15.3	6.8	33	6 53.3	6 54.4	6 34.4	3.3	1.5	9.3	4.3	15.3	7.0
34	6 38.5	6 39.6	6 20.3	3.4	1.5	9.4	4.2	15.4	6.8	34	6 53.5	6 54.6	6 34.7	3.4	1.6	9.4	4.3	15.4	7.1
35	6 38.8	6 39.8	6 20.6	3.5	1.5	9.5	4.2	15.5	6.8	35	6 53.8	6 54.9	6 34.9	3.5	1.6	9.5	4.4	15.5	7.1
36	6 39.0	6 40.1	6 20.8	3.6	1.6	9.6	4.2	15.6	6.9	36	6 54.0	6 55.1	6 35.1	3.6	1.7	9.6	4.4	15.6	7.2
37	6 39.3	6 40.3	6 21.1	3.7	1.6	9.7	4.3	15.7	6.9	37	6 54.3	6 55.4	6 35.4	3.7	1.7	9.7	4.4	15.7	7.2
38	6 39.5	6 40.6	6 21.3	3.8	1.7	9.8	4.3	15.8	7.0	38	6 54.5	6 55.6	6 35.6	3.8	1.7	9.8	4.5	15.8	7.2
39	6 39.8	6 40.8	6 21.5	3.9	1.7	9.9	4.4	15.9	7.0	39	6 54.8	6 55.9	6 35.9	3.9	1.8	9.9	4.5	15.9	7.3
40	6 40.0	6 41.1	6 21.8	4.0	1.8	10.0	4.4	16.0	7.1	40	6 55.0	6 56.1	6 36.1	4.0	1.8	10.0	4.6	16.0	7.3
41	6 40.3	6 41.3	6 22.0	4.1	1.8	10.1	4.5	16.1	7.1	41	6 55.3	6 56.4	6 36.3	4.1	1.9	10.1	4.6	16.1	7.4
42	6 40.5	6 41.6	6 22.3	4.2	1.9	10.2	4.5	16.2	7.2	42	6 55.5	6 56.6	6 36.6	4.2	1.9	10.2	4.7	16.2	7.4
43	6 40.8	6 41.8	6 22.5	4.3	1.9	10.3	4.5	16.3	7.2	43	6 55.8	6 56.9	6 36.8	4.3	2.0	10.3	4.7	16.3	7.5
44	6 41.0	6 42.1	6 22.7	4.4	1.9	10.4	4.6	16.4	7.2	44	6 56.0	6 57.1	6 37.0	4.4	2.0	10.4	4.8	16.4	7.5
45	6 41.3	6 42.3	6 23.0	4.5	2.0	10.5	4.6	16.5	7.3	45	6 56.3	6 57.4	6 37.3	4.5	2.1	10.5	4.8	16.5	7.6
46	6 41.5	6 42.6	6 23.2	4.6	2.0	10.6	4.7	16.6	7.3	46	6 56.5	6 57.6	6 37.5	4.6	2.1	10.6	4.9	16.6	7.6
47	6 41.8	6 42.8	6 23.4	4.7	2.1	10.7	4.7	16.7	7.4	47	6 56.8	6 57.9	6 37.8	4.7	2.2	10.7	4.9	16.7	7.7
48	6 42.0	6 43.1	6 23.7	4.8	2.1	10.8	4.8	16.8	7.4	48	6 57.0	6 58.1	6 38.0	4.8	2.2	10.8	5.0	16.8	7.7
49	6 42.3	6 43.4	6 23.9	4.9	2.2	10.9	4.8	16.9	7.5	49	6 57.3	6 58.4	6 38.2	4.9	2.2	10.9	5.0	16.9	7.7
50	6 42.5	6 43.6	6 24.2	5.0	2.2	11.0	4.9	17.0	7.5	50	6 57.5	6 58.6	6 38.5	5.0	2.3	11.0	5.0	17.0	7.8
51	6 42.8	6 43.9	6 24.4	5.1	2.3	11.1	4.9	17.1	7.6	51	6 57.8	6 58.9	6 38.7	5.1	2.3	11.1	5.1	17.1	7.8
52	6 43.0	6 44.1	6 24.6	5.2	2.3	11.2	4.9	17.2	7.6	52	6 58.0	6 59.1	6 39.0	5.2	2.4	11.2	5.1	17.2	7.9
53	6 43.3	6 44.4	6 24.9	5.3	2.3	11.3	5.0	17.3	7.6	53	6 58.3	6 59.4	6 39.2	5.3	2.4	11.3	5.2	17.3	7.9
54	6 43.5	6 44.6	6 25.1	5.4	2.4	11.4	5.0	17.4	7.7	54	6 58.5	6 59.6	6 39.4	5.4	2.5	11.4	5.2	17.4	8.0
55	6 43.8	6 44.9	6 25.4	5.5	2.4	11.5	5.1	17.5	7.7	55	6 58.8	6 59.9	6 39.7	5.5	2.5	11.5	5.3	17.5	8.0
56	6 44.0	6 45.1	6 25.6	5.6	2.5	11.6	5.1	17.6	7.8	56	6 59.0	7 00.1	6 39.9	5.6	2.6	11.6	5.3	17.6	8.1
57	6 44.3	6 45.4	6 25.8	5.7	2.5	11.7	5.2	17.7	7.8	57	6 59.3	7 00.4	6 40.2	5.7	2.6	11.7	5.4	17.7	8.1
58	6 44.5	6 45.6	6 26.1	5.8	2.6	11.8	5.2	17.8	7.9	58	6 59.5	7 00.6	6 40.4	5.8	2.7	11.8	5.4	17.8	8.2
59	6 44.8	6 45.9	6 26.3	5.9	2.6	11.9	5.3	17.9	7.9	59	6 59.8	7 00.9	6 40.6	5.9	2.7	11.9	5.5	17.9	8.2
60	6 45.0	6 46.1	6 26.6	6.0	2.7	12.0	5.3	18.0	8.0	60	7 00.0	7 01.1	6 40.9	6.0	2.8	12.0	5.5	18.0	8.3

26NVJ084

Figure 4B.—Nautical Almanac Increments and Corrections page.



# ALTITUDE CORRECTION TABLES 10°-90°—SUN, STARS, PLANETS

OCT.—MAR. SUN			APR.—SEPT.			STARS AND PLANETS		DIP						
App. Alt.	Lower Limb	Upper Limb	App. Alt.	Lower Limb	Upper Limb	App. Alt.	Corr <sup>n</sup>	App. Alt.	Additional Corr <sup>n</sup>	Ht. of Eye	Corr <sup>n</sup>	Ht. of Eye	Ht. of Eye	Corr <sup>n</sup>
0			0			0			<b>1984</b>	m		ft.	m	
9 34	+10.8	-21.5	9 39	+10.6	-21.2	9 56	-5.3		<b>VENUS</b>	2.4	-2.8	8.0	1.0	-1.8
9 45	+10.9	-21.4	9 51	+10.7	-21.1	10 08	-5.2			2.6	-2.9	8.6	1.5	-2.2
9 56	+11.0	-21.3	10 03	+10.8	-21.0	10 20	-5.1	Jan. 1-Dec. 12		2.8	-3.0	9.2	2.0	-2.5
10 08	+11.1	-21.2	10 15	+10.9	-20.9	10 33	-5.0	0		3.0	-3.1	9.8	2.5	-2.8
10 21	+11.2	-21.1	10 27	+11.0	-20.8	10 46	-4.9	60 + 0.1		3.2	-3.2	10.5	3.0	-3.0
10 34	+11.3	-21.0	10 40	+11.1	-20.7	11 00	-4.8		Dec. 13-Dec. 31	3.4	-3.3	11.2	See table	
10 47	+11.4	-20.9	10 54	+11.2	-20.6	11 14	-4.7	0		3.6	-3.3	11.9	←	
11 01	+11.5	-20.8	11 08	+11.3	-20.5	11 29	-4.6	0		3.8	-3.4	12.6	m	
11 15	+11.6	-20.7	11 23	+11.4	-20.4	11 45	-4.5	41 + 0.2		4.0	-3.5	13.3	20	-7.9
11 30	+11.7	-20.6	11 38	+11.5	-20.3	12 01	-4.4	76 + 0.1		4.3	-3.6	14.1	22	-8.3
11 46	+11.8	-20.5	12 10	+11.6	-20.2	12 18	-4.4			4.5	-3.7	14.9	24	-8.6
12 02	+11.9	-20.4	12 28	+11.7	-20.1	12 35	-4.2			4.7	-3.8	15.7	26	-9.0
12 19	+12.0	-20.3	12 46	+11.8	-20.0	12 54	-4.1		<b>MARS</b>	5.0	-3.9	16.5	28	-9.3
12 37	+12.1	-20.2	13 05	+11.9	-19.9	13 13	-4.0	Jan. 1-Mar. 4		5.2	-4.0	17.4		
12 55	+12.2	-20.1	13 24	+12.0	-19.8	13 33	-3.9	0		5.5	-4.1	18.3	30	-9.6
13 14	+12.3	-20.0	13 45	+12.1	-19.7	13 54	-3.8	60 + 0.1		5.8	-4.2	19.1	32	-10.0
13 35	+12.4	-19.9	14 07	+12.2	-19.6	14 16	-3.7		Mar. 5-Apr. 24	6.1	-4.3	20.1	34	-10.3
13 56	+12.5	-19.8	14 30	+12.3	-19.5	14 40	-3.6	0		6.3	-4.4	21.0	36	-10.6
14 18	+12.6	-19.7	14 54	+12.4	-19.4	15 04	-3.5	41 + 0.2		6.6	-4.5	22.0	38	-10.8
14 42	+12.7	-19.6	15 19	+12.5	-19.3	15 30	-3.4	76 + 0.1		6.9	-4.6	22.9		
15 06	+12.8	-19.5	15 46	+12.6	-19.2	15 57	-3.3		Apr. 25-June 15	7.2	-4.8	23.9	40	-11.1
15 32	+12.9	-19.4	16 14	+12.7	-19.1	16 26	-3.2	0		7.5	-4.9	24.9	42	-11.4
15 59	+13.0	-19.3	16 44	+12.8	-19.0	16 56	-3.1	34 + 0.3		7.9	-5.0	26.0	44	-11.7
16 28	+13.1	-19.2	17 15	+12.9	-18.9	17 28	-3.0	60 + 0.2		8.2	-5.1	27.1	46	-11.9
16 59	+13.2	-19.1	17 48	+13.0	-18.8	18 02	-2.9	80 + 0.1		8.5	-5.1	28.1	48	-12.2
17 32	13.3	19.0	18 24	13.1	18.7	18 38	-2.8		June 16-Aug. 27	8.8	-5.2	29.2		ft.
18 06	13.4	18.9	19 01	13.2	18.6	19 17	-2.7	0		9.2	-5.3	30.4	2	-1.4
18 42	13.5	18.8	19 42	13.3	18.5	19 58	-2.6	41 + 0.2		9.5	-5.4	31.5	4	-1.9
19 21	13.6	18.7	20 25	13.4	18.4	20 42	-2.5	76 + 0.1		9.9	-5.5	32.7	6	-2.4
20 03	13.7	18.6	21 11	13.5	18.3	21 28	-2.4	0		10.3	-5.6	33.9	8	-2.7
20 48	13.8	18.5	22 00	13.6	18.2	22 19	-2.3	41 + 0.2		10.6	-5.7	35.1	10	-3.1
21 35	13.9	18.4	22 54	13.7	18.1	23 13	-2.2	76 + 0.1	Aug. 28-Dec. 31	11.0	-5.8	36.3	See table	
22 26	14.0	18.3	23 51	13.8	18.0	24 11	-2.1	0		11.4	-5.9	37.6	←	
23 22	14.1	18.2	24 53	13.9	17.9	25 14	-2.0	60 + 0.1		11.8	-6.0	38.9		ft.
24 21	14.2	18.1	26 00	14.0	17.8	26 22	-1.9			12.2	-6.1	40.1	70	-8.1
25 26	14.3	18.0	27 13	14.1	17.7	27 36	-1.8			12.6	-6.2	41.5	75	-8.4
26 36	14.4	17.9	28 33	14.2	17.6	28 56	-1.7			13.0	-6.3	42.8	80	-8.7
27 52	14.5	17.8	30 00	14.3	17.5	30 24	-1.6			13.4	-6.4	44.2	85	-8.9
29 15	14.6	17.7	31 35	14.4	17.4	32 00	-1.5			13.8	-6.5	45.5	90	-9.2
30 46	14.7	17.6	33 20	14.5	17.3	33 45	-1.4			14.2	-6.6	46.9	95	-9.5
32 26	14.8	17.5	35 17	14.6	17.2	35 40	-1.3			14.7	-6.7	48.4		
34 17	14.9	17.4	37 26	14.7	17.1	37 48	-1.2			15.1	-6.8	49.8		
36 20	15.0	17.3	39 50	14.8	17.0	40 08	-1.1			15.5	-6.9	51.3	100	-9.7
38 36	15.1	17.2	42 31	14.9	16.9	42 44	-1.0			16.0	-7.0	52.8	105	-9.9
41 08	15.2	17.1	45 31	15.0	16.8	45 36	-0.9			16.5	-7.1	54.3	110	-10.2
43 59	15.3	17.0	48 55	15.1	16.7	48 47	-0.8			16.9	-7.2	55.8	115	-10.4
47 10	15.4	16.9	52 44	15.2	16.6	52 18	-0.7			17.4	-7.3	57.4	120	-10.6
50 46	15.5	16.8	57 02	15.3	16.5	56 11	-0.6			17.9	-7.4	58.9	125	-10.8
54 49	15.6	16.7	61 51	15.4	16.4	60 28	-0.6			18.4	-7.5	60.5		
59 23	15.7	16.6	67 17	15.5	16.3	65 08	-0.5			18.8	-7.6	62.1	130	-11.1
64 30	15.8	16.5	73 16	15.6	16.2	70 11	-0.4			19.3	-7.7	63.8	135	-11.3
70 12	15.9	16.4	79 43	15.7	16.1	75 34	-0.3			19.8	-7.8	65.4	140	-11.5
76 26	16.0	16.3	86 32	15.8	16.0	81 13	-0.2			20.4	-7.9	67.1	145	-11.7
83 05	16.1	16.2	90 00	15.9	15.9	87 03	-0.1			20.9	-8.0	68.8	150	-11.9
90 00						90 00	0.0			21.4	-8.1	70.5	155	-12.1

App. Alt. = Apparent altitude    Sextant altitude corrected for index error and dip.    26NVJ085

Figure 4C.—Nautical Almanac Altitude Correction Tables.

26NVJ090

LATITUDE CONTRARY NAME TO DECLINATION

L.H.A. 30°, 330°

Dec.	30°			31°			32°			33°			34°			35°			36°			37°			Dec.
	Mc	d	Z	Mc	d	Z	Mc	d	Z	Mc	d	Z	Mc	d	Z	Mc	d	Z	Mc	d	Z	Mc	d	Z	
0	48 35.4	456	130.9	47 55.8	463	131.7	47 15.6	471	132.5	46 34.7	478	133.3	45 53.2	484	134.1	45 11.2	490	134.8	44 28.7	496	135.5	43 45.6	501	136.2	0
1	47 49.8	461	131.9	47 09.5	468	132.7	46 28.5	475	133.5	45 46.9	481	134.2	45 04.8	487	134.9	44 22.2	493	135.6	43 39.1	499	136.3	42 55.5	505	136.9	1
2	47 03.7	454	132.8	46 22.7	473	133.6	45 41.0	479	134.3	45 58.8	485	135.0	44 16.1	491	135.7	43 32.9	497	136.4	42 49.2	502	137.1	42 05.0	507	137.7	2
3	46 17.2	470	133.7	45 35.4	476	134.5	44 53.1	482	135.2	44 10.3	488	135.9	43 27.0	494	136.5	42 43.2	500	137.2	41 59.0	505	137.8	41 14.3	510	138.4	3
4	45 30.2	477	134.6	44 47.8	480	135.3	44 04.9	486	136.0	43 21.5	492	136.7	42 37.6	498	137.3	41 53.2	502	137.9	41 08.5	508	138.5	40 23.3	512	139.1	4
5	44 42.8	477	135.5	43 59.8	484	136.2	42 16.3	490	136.8	42 32.3	495	137.5	41 47.8	500	138.1	41 03.0	505	138.7	40 17.7	509	139.2	39 32.1	514	139.8	5
6	43 55.1	482	136.3	43 11.4	487	137.0	42 27.3	492	137.6	41 42.8	498	138.2	40 57.8	503	138.8	40 12.5	508	139.4	39 26.8	513	139.9	38 40.7	517	140.4	6
7	43 06.9	484	137.2	42 22.7	490	137.8	41 38.1	495	138.4	40 53.0	501	139.0	40 07.5	505	139.5	39 21.7	510	140.1	38 35.5	514	140.6	37 49.0	519	141.1	7
8	42 18.5	486	138.0	41 33.7	493	138.6	40 48.5	498	139.1	40 02.9	503	139.7	39 17.0	507	140.2	38 30.7	512	140.7	37 44.1	517	141.2	36 57.1	520	141.7	8
9	41 29.7	489	138.8	40 44.4	497	139.3	39 58.7	501	139.9	39 12.6	506	140.4	38 26.2	510	140.9	37 39.5	515	141.4	36 52.4	518	141.9	36 05.1	523	142.3	9
10	40 40.6	492	139.5	39 54.7	499	140.1	39 08.6	504	140.6	38 22.0	508	141.1	37 35.2	513	141.6	36 48.0	516	142.1	36 00.6	521	142.5	35 12.8	524	142.9	10
11	39 51.2	497	140.3	39 04.8	501	140.8	38 18.2	506	141.3	37 31.2	510	141.8	36 43.9	514	142.2	35 56.4	519	142.7	35 08.5	522	143.1	34 20.4	526	143.5	11
12	39 01.5	500	141.0	38 14.7	504	141.5	37 27.6	508	142.0	36 40.2	512	142.4	35 52.5	517	142.9	35 04.5	520	143.3	34 18.3	524	143.7	33 27.8	528	144.1	12
13	38 11.5	502	141.7	37 24.7	507	142.2	36 36.8	511	142.6	35 48.9	515	143.1	35 00.8	519	143.5	34 12.5	522	143.9	33 23.9	526	144.3	32 35.0	530	144.7	13
14	37 21.3	504	142.4	36 33.7	509	142.8	35 45.7	513	143.3	34 57.5	517	143.7	34 09.0	520	144.1	33 20.3	524	144.5	32 31.3	527	144.9	31 52.0	532	145.2	14
15	36 30.9	507	143.1	35 42.8	511	143.5	34 54.4	516	143.9	34 05.8	519	144.3	33 17.0	522	144.7	32 27.9	525	145.1	31 38.6	528	145.4	30 59.1	533	145.8	15
16	35 40.2	508	143.7	34 51.7	512	144.1	34 03.0	518	144.5	33 14.0	520	144.9	32 24.8	524	145.3	31 35.4	527	145.7	30 45.7	530	146.0	29 59.9	533	146.3	16
17	34 49.4	511	144.4	34 00.5	513	144.8	33 11.4	519	145.2	32 22.0	522	145.5	31 32.4	525	145.9	30 42.7	528	146.2	29 52.7	531	146.5	29 02.3	535	146.8	17
18	33 58.3	513	145.0	33 09.0	516	145.4	32 19.5	519	145.8	31 29.8	523	146.1	30 39.9	526	146.4	29 49.8	529	146.8	28 59.6	533	147.1	28 09.1	537	147.4	18
19	33 07.0	515	145.6	32 17.4	518	146.0	31 27.6	522	146.3	30 37.5	524	146.7	29 47.3	528	147.0	28 56.9	531	147.3	28 06.3	534	147.6	27 15.6	539	147.9	19
20	32 15.6	516	146.2	31 25.6	520	146.6	30 35.4	523	146.9	29 45.1	526	147.2	28 54.5	529	147.5	28 03.8	532	147.8	27 12.9	535	148.1	26 21.9	541	148.4	20
21	31 24.0	518	146.8	30 33.6	522	147.2	29 43.1	524	147.5	28 52.5	528	147.8	28 01.6	530	148.1	27 10.6	533	148.4	26 19.5	536	148.6	25 28.2	543	148.9	21
22	30 32.2	520	147.4	29 41.5	524	147.7	28 50.7	526	148.0	27 59.7	529	148.3	27 08.6	532	148.6	26 17.3	535	148.9	25 25.9	537	149.1	24 34.3	545	149.4	22
23	29 40.2	521	148.0	28 49.2	526	148.3	27 58.1	527	148.6	27 06.8	529	148.9	26 15.4	532	149.1	25 23.9	536	149.4	24 32.2	539	149.6	23 40.4	546	149.9	23
24	28 48.1	523	148.6	27 56.9	528	148.9	27 05.4	529	149.1	26 13.9	531	149.4	25 22.2	534	149.6	24 30.3	538	149.9	23 38.4	541	150.1	22 46.3	548	150.3	24
25	27 55.9	524	149.1	27 04.3	529	149.4	26 12.6	530	149.7	25 20.8	532	149.9	24 28.8	535	150.1	23 36.7	537	150.4	22 44.5	540	150.6	21 52.2	548	150.8	25
26	27 03.5	524	149.7	26 11.7	529	149.9	25 19.7	531	150.2	24 27.6	533	150.4	23 35.3	535	150.6	22 43.0	538	150.8	21 50.5	540	151.0	20 58.0	548	151.2	26
27	26 11.1	527	150.2	25 18.9	529	150.5	24 26.6	531	150.7	23 34.3	534	150.9	22 41.8	537	151.1	21 49.2	539	151.3	20 56.5	541	151.5	20 03.7	548	151.7	27
28	25 18.4	527	150.8	24 26.0	530	151.0	23 33.5	532	151.2	22 40.9	535	151.4	21 48.1	537	151.6	20 55.3	540	151.8	20 02.4	542	152.0	19 09.4	548	152.2	28
29	24 25.7	528	151.3	23 33.0	530	151.5	22 40.3	532	151.7	21 47.4	534	151.9	20 54.4	538	152.1	20 01.3	540	152.3	19 08.2	543	152.4	18 15.0	545	152.6	29
30	23 32.9	529	151.8	22 40.0	532	152.0	21 46.9	534	152.2	20 53.8	537	152.4	20 00.6	539	152.6	19 07.3	541	152.7	18 13.9	543	152.9	17 20.5	548	153.0	30
31	22 40.0	531	152.3	21 46.8	533	152.5	20 53.5	535	152.7	20 00.1	537	152.9	19 06.7	539	153.0	18 13.2	542	153.2	17 19.6	544	153.3	16 26.0	548	153.5	31
32	21 46.9	531	152.8	20 53.5	534	153.0	20 00.0	536	153.2	19 06.4	538	153.3	18 12.8	541	153.5	17 19.0	542	153.6	16 25.4	544	153.8	15 31.4	548	153.9	32
33	20 53.8	532	153.3	20 00.1	534	153.5	19 06.4	536	153.7	18 12.6	539	153.8	17 18.7	540	153.9	16 24.8	543	154.1	15 30.8	545	154.2	14 36.8	548	154.3	33
34	20 00.6	533	153.8	19 06.7	535	154.0	18 12.8	538	154.1	17 18.7	540	154.2	16 24.7	543	154.4	15 30.5	544	154.5	14 36.3	546	154.6	13 42.1	548	154.7	34
35	19 07.3	533	154.3	18 13.2	536	154.5	17 19.0	538	154.6	16 24.6	540	154.7	15 30.5	543	154.8	14 36.2	544	155.0	13 41.8	546	155.1	12 47.4	548	155.2	35
36	18 13.9	534	154.8	17 19.1	536	154.9	16 25.2	538	155.1	15 30.8	540	155.2	14 36.3	543	155.3	13 41.8	544	155.4	12 47.2	546	155.5	11 52.6	548	155.6	36
37	17 20.5	535	155.3	16 26.0	537	155.4	15 31.4	539	155.5	14 36.8	541	155.6	13 42.1	543	155.7	12 47.4	545	155.8	11 52.6	546	155.9	10 57.8	548	156.0	37
38	16 27.0	535	155.7	15 32.3	538	155.9	14 37.5	540	156.0	13 42.7	542	156.1	12 47.8	545	156.2	11 52.9	545	156.3	10 58.0	547	156.3	10 03.0	548	156.4	38
39	15 33.4	536	156.2	14 38.5	538	156.3	13 43.5	540	156.4	12 48.5	542	156.5	11 53.5	544	156.6	10 58.4	546	156.7	10 03.3	547	156.8	9 08.1	548	156.8	39
40	14 39.8	537	156.7	13 44.7	539	156.8	12 49.5	540	156.9	11 54.3	542	157.0	10 59.1	544	157.0	10 03.8	545	157.1	9 08.6	546	157.2	8 13.2	548	157.2	40
41	13 46.1	537	157.1	12 50.8	539	157.2	11 55.5	541	157.3	11 00.1	543	157.4	10 04.7	544	157.5	9 09.3	546	157.5	8 13.8	546	157.6	7 18.3	548	157.6	41
42	12 52.4	538	157.6	11 56.9	540	157.7	11 01.4	541	157.8	10 05.8	542	157.8	9 10.3	543	157.9	8 14.7	547	157.9	7 19.0	548	158.0	6 23.4	548	158.0	42
43	11 58.6	538	158.0	11 02.9	540	158.1	10 07.3	542	158.2	9 11.5	543	158.3	8 15.8	545	158.3	7 20.0	546	158.4	6 24.2	548	158.4	5 28.4	548	158.4	43
44	11 04.8	539	158.5	10 08.9	540	158.6	9 13.1	542	158.6	8 17.2	543	158.7	7 21.3	545	158.7	6 25.4	547	158.8	5 29.4	548	158.8	4 35.5	548	158.8	44
45	10 10.9	539	158.9	9 14.9	540	159.0	8 18.9	542	159.1	7 22.8	543	159.1	6 26.8	546	159.2	5 30.7	547	159.2	4 34.6	548	159.2	3 38.5	548	159.2	45
46	9 17.0	540	159.4	8 20.9																					

INTERPOLATION TABLE

Dec Inc	Altitude Difference (d)										Double Second Diff and Corr.	Dec Inc	Altitude Difference (d)										Double Second Diff and Corr.															
	Tens				Decimals								Units				Tens				Decimals						Units											
	10'	20'	30'	40'	0'	1'	2'	3'	4'	5'			6'	7'	8'	9'	10'	20'	30'	40'	50'	0'		1'	2'	3'	4'	5'	6'	7'	8'	9'						
16.0	26	53	80	106	133	0	0003	0508	1114	1619	2225	10	24.0	40	80	120	160	200	0	0004	0812	1620	2429	3337	08	24.0	40	80	120	160	200	1	0004	0913	1721	2529	3337	25
16.1	27	53	80	107	134	1	0003	0609	1114	1720	2225	10	24.1	40	80	120	160	201	1	0004	0913	1721	2529	3338	25	24.1	40	80	121	161	201	2	0105	0913	1721	2529	3338	41
16.2	27	54	81	108	135	2	0103	0609	1214	1720	2325	10	24.2	40	80	121	161	201	2	0105	0913	1822	2630	3438	58	24.2	40	81	121	162	202	3	0105	0913	1822	2630	3438	58
16.3	27	54	81	109	136	3	0104	0609	1215	1720	2326	10	24.3	40	81	121	162	202	3	0206	1014	1822	2630	3438	58	24.3	41	81	122	163	203	4	0206	1014	1822	2630	3438	58
16.4	27	55	82	109	137	4	0104	0709	1215	1820	2326	10	24.4	41	81	122	163	203	4	0206	1014	1822	2731	3539	91	24.4	41	82	123	163	204	5	0207	1115	1923	2731	3539	91
16.5	28	55	83	110	138	5	0104	0710	1215	1821	2326	10	24.5	41	82	123	163	204	5	0307	1115	1923	2731	3540	123	24.5	41	83	124	165	206	6	0307	1115	1923	2731	3540	123
16.6	28	55	83	111	138	6	0204	0710	1316	1821	2427	10	24.6	41	82	123	164	205	6	0307	1116	2024	2832	3640	140	24.6	42	83	124	165	207	7	0307	1116	2024	2832	3640	140
16.7	28	56	84	112	139	7	0205	0810	1316	1921	2427	10	24.7	42	83	124	165	207	7	0408	1216	2024	2832	3640	156	24.7	42	83	125	166	208	8	0408	1216	2024	2832	3640	156
16.8	28	56	84	112	140	8	0205	0811	1316	1922	2427	10	24.8	42	83	125	166	208	8	0408	1217	2125	2934	3741	173	24.8	42	83	125	166	208	9	0408	1217	2125	2934	3741	173
16.9	29	57	85	113	141	9	0003	0609	1215	1720	2326	10	25.0	41	83	125	166	208	9	0005	0913	1721	2530	3438	189	25.0	41	83	125	167	209	0	0005	0913	1721	2530	3438	189
17.0	28	56	85	113	141	0	0003	0609	1215	1821	2427	10	25.1	42	83	125	167	209	0	0105	0914	1822	2631	3539	206	25.1	42	83	125	167	209	1	0105	0914	1822	2631	3539	206
17.1	28	57	86	114	142	1	0103	0609	1215	1821	2427	10	25.2	42	84	126	168	210	1	0106	1014	1923	2731	3540	222	25.2	42	84	126	168	210	2	0106	1014	1923	2731	3540	222
17.2	28	57	86	114	143	2	0104	0710	1315	1821	2427	10	25.3	42	84	126	169	211	2	0206	1014	1923	2731	3540	239	25.3	42	85	127	169	211	3	0206	1014	1923	2731	3540	239
17.3	29	58	87	116	145	3	0104	0710	1316	1922	2427	10	25.4	42	85	127	169	212	3	0206	1015	1923	2832	3640	255	25.4	42	85	127	169	212	4	0206	1015	1923	2832	3640	255
17.4	29	58	87	116	145	4	0104	0710	1316	1922	2528	10	25.5	43	85	128	170	213	4	0307	1115	1923	2832	3640	272	25.5	43	85	128	170	213	5	0307	1115	1923	2832	3640	272
17.5	29	59	88	117	146	5	0205	0810	1316	1922	2528	10	25.6	43	85	128	171	213	5	0307	1116	2024	2832	3741	288	25.6	43	85	128	171	213	6	0307	1116	2024	2832	3741	288
17.6	29	59	88	117	147	6	0205	0811	1417	2023	2528	10	25.7	43	86	129	172	214	6	0308	1216	2125	2934	3741	304	25.7	43	86	129	172	214	7	0308	1216	2125	2934	3741	304
17.7	30	59	89	118	148	7	0205	0811	1417	2023	2629	10	25.8	43	86	129	172	215	7	0408	1317	2226	3035	3944	321	25.8	43	86	129	172	215	8	0408	1317	2226	3035	3944	321
17.8	30	60	89	119	149	8	0306	0912	1518	2124	2731	10	25.9	44	87	130	173	216	8	0408	1317	2226	3136	4045	337	25.9	44	87	130	173	216	9	0408	1317	2226	3136	4045	337
17.9	30	60	90	120	150	9	0003	0609	1215	1822	2528	10	26.0	43	86	130	173	216	9	0005	0914	1823	2732	3641	354	26.0	43	87	130	174	217	0	0005	0914	1823	2732	3641	354
18.0	30	60	90	120	151	0	0003	0610	1316	1922	2528	10	26.1	43	87	131	174	217	0	0105	1014	1923	2732	3641	370	26.1	43	87	131	174	217	1	0105	1014	1923	2732	3641	370
18.1	30	60	91	121	151	1	0104	0710	1316	1922	2528	10	26.2	43	87	131	174	218	1	0106	1015	1923	2833	3842	487	26.2	43	88	132	175	218	2	0106	1015	1923	2833	3842	487
18.2	30	61	91	122	152	2	0104	0710	1316	1923	2629	10	26.3	44	88	132	176	220	2	0206	1115	1924	2833	3842	504	26.3	44	88	132	176	220	3	0206	1115	1924	2833	3842	504
18.3	31	61	92	123	153	3	0104	0710	1417	2023	2629	10	26.4	44	88	132	176	220	3	0207	1115	2024	2934	3944	521	26.4	44	89	133	177	221	4	0207	1115	2024	2934	3944	521
18.4	31	61	92	123	153	4	0205	0811	1417	2023	2730	10	26.5	44	89	133	177	222	4	0307	1116	2024	2934	3944	537	26.5	44	89	133	177	222	5	0307	1116	2024	2934	3944	537
18.5	31	62	93	123	154	5	0205	0811	1417	2023	2730	10	26.6	44	89	133	177	222	5	0308	1216	2125	3035	3944	554	26.6	44	89	133	177	222	6	0308	1216	2125	3035	3944	554
18.6	31	62	93	124	155	6	0205	0811	1417	2023	2730	10	26.7	45	89	134	178	223	6	0408	1317	2226	3136	4045	570	26.7	45	89	134	178	223	7	0408	1317	2226	3136	4045	570
18.7	31	63	94	125	156	7	0206	0912	1518	2124	2730	10	26.8	45	90	134	179	224	7	0408	1317	2226	3136	4045	587	26.8	45	90	134	179	224	8	0408	1317	2226	3136	4045	587
18.8	32	63	94	126	157	8	0306	0912	1518	2124	2731	10	26.9	45	90	135	180	225	8	0005	0914	1823	2732	3741	604	26.9	45	90	135	180	225	9	0005	0914	1823	2732	3741	604
18.9	32	63	95	126	158	9	0003	0610	1316	1923	2629	10	27.0	45	90	135	180	225	9	0005	1014	1923	2833	3742	620	27.0	45	90	135	180	226	0	0005	1014	1923	2833	3742	620
19.0	31	63	95	127	159	0	0004	0710	1317	2023	2629	10	27.1	45	90	136	181	226	0	0105	1015	1924	2833	3842	637	27.1	45	90	136	181	226	1	0105	1015	1924	2833	3842	637
19.1	32	63	95	127	159	1	0104	0710	1417	2023	2730	10	27.2	45	90	136	181	226	1	0106	1115	2024	2934	3944	653	27.2	45	91	136	182	227	2	0106	1115	2024	2934	3944	653
19.2	32	64	96	128	160	2	0104	0711	1417	2024	2730	10	27.3	45	91	136	182	227	2	0206	1116	2024	2934	3944	670	27.3	45	91	137	183	228	3	0206	1116	2024	2934	3944	670
19.3	32	64	96	129	161	3	0105	0811	1418	2124	2731	10	27.4	46	91	137	183	228	3	0207	1116	2125	3035	3944	687	27.4	46	91	137	183	228	4	0207	1116	2125	3035	3944	687
19.4	32	65	97	129	162	4	0205	0811	1518	2124	2831	10	27.5	46	92	138	183	229	4	0307	1116	2125	3035	3944	703	27.5	46	92	138	183	229	5	0307	1116	2125	3035	3944	703
19.5	33	65	98	130	163	5	0205	0812	1518	2125	2831	10	27.6	46	92	138	184	230	5	0308	1217	2226	3136	4045	720	27.6	46	93	139	185	231	6	0308	1217	2226	3136	4045	720
19.6	33	65	98	131	163	6	0306	0912	1519	2225	2832	10	27.7	46	93	139	185	231	6	0408	1318	2327	3237	4146	737	27.7	46	93	139	185	231	7						

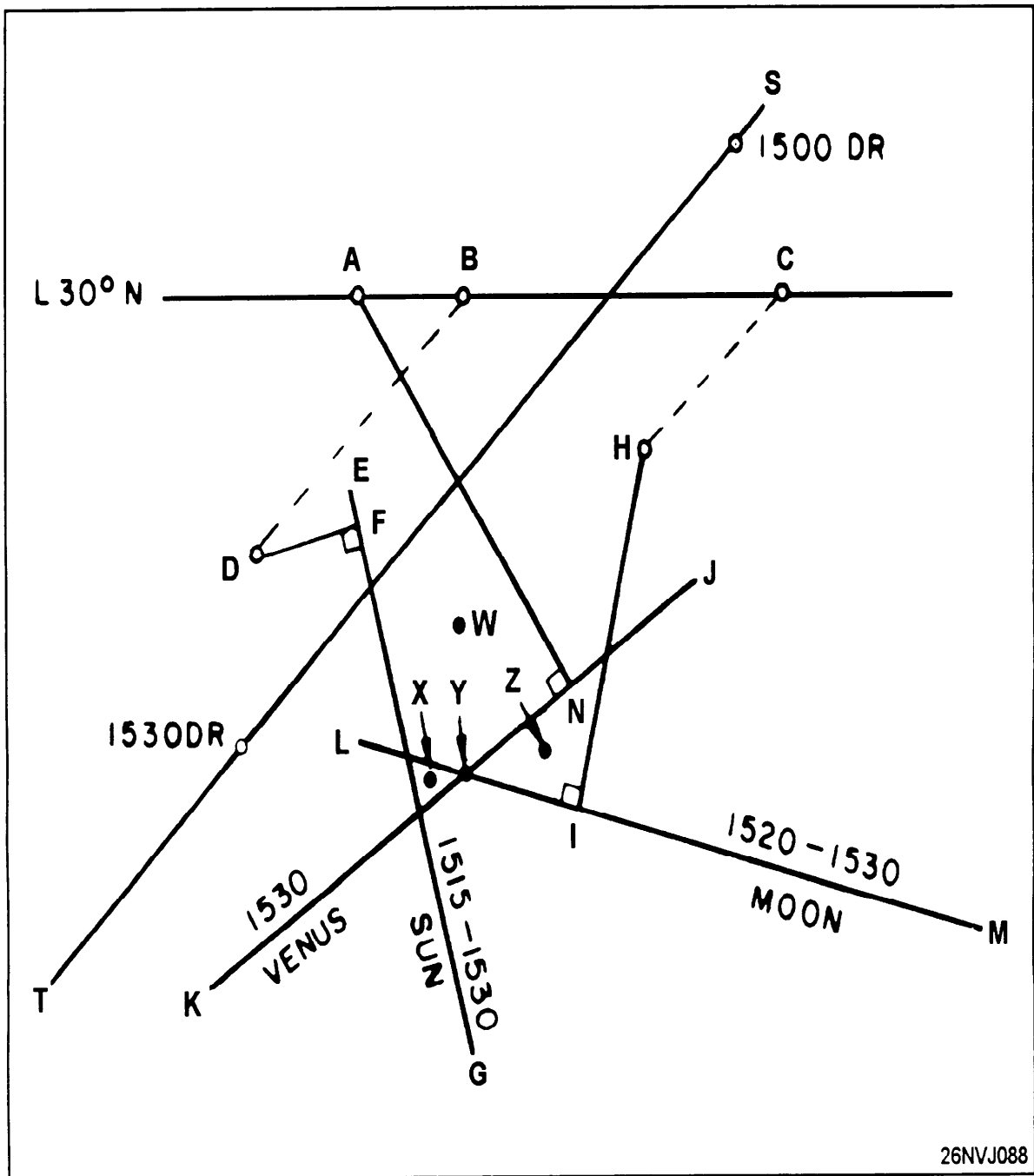

Figure 4F.—Celestial Fix.

G.M.T.	SUN		MOON					Lat	Twilight		Sunrise	Moonrise			
	G.H.A.	Dec.	G.H.A.	V	Dec.	d	M.P.		Naut.	Civil		1	2	3	4
									h m	h m		h m	h m	h m	h m
1 00	178 25.7	N10 01.8	130 12.1	10.3	N 5	15.1	15.9	60.3	N 72	01 36	09 05	11 23	13 47	16 48	
01	193 25.7	01.1	144 41.4	10.2	4	59.2	15.8	60.2	68	02 21	09 12	11 12	13 13	15 22	
02	208 25.8	18 00.5	159 10.6	10.4	4	43.4	15.8	60.2	66	00 39	09 14	11 08	13 01	14 59	
03	223 25.8	17 59.9	173 40.0	10.4	4	27.6	15.9	60.2	64	01 46	09 17	11 04	12 52	14 41	
04	238 25.8	59.3	188 09.4	10.4	4	11.7	15.9	60.2	62	02 19	09 19	11 01	12 43	14 26	
05	253 25.9	58.6	202 38.8	10.4	3	55.8	15.9	60.2	60	00 36	09 20	10 59	12 36	14 14	
06	268 25.9	N17 58.0	217 08.2	10.5	N 3	39.9	15.9	60.2	N 58	01 36	09 22	10 56	12 30	14 03	
07	283 26.0	57.4	231 37.7	10.5	3	24.0	15.9	60.2	56	02 07	09 23	10 54	12 24	13 54	
08	298 26.0	56.7	246 07.2	10.6	3	08.1	15.9	60.1	54	02 29	09 24	10 52	12 19	13 46	
09	313 26.0	56.1	260 36.8	10.6	2	52.2	15.9	60.1	52	02 47	09 25	10 51	12 15	13 38	
10	328 26.1	55.5	275 06.4	10.7	2	36.3	16.0	60.1	50	03 02	09 26	10 49	12 11	13 32	
11	343 26.1	54.8	289 36.1	10.6	2	20.3	15.9	60.1	45	03 30	09 28	10 46	12 02	13 18	
12	358 26.2	N17 54.2	304 05.7	10.7	N 2	04.4	16.0	60.1	N 40	03 52	09 30	10 43	11 55	13 06	
13	13 26.2	53.6	318 35.4	10.8	1	48.4	15.9	60.1	35	04 09	09 32	10 41	11 49	12 56	
14	28 26.2	52.9	333 05.2	10.7	1	32.5	15.9	60.0	30	04 23	09 33	10 39	11 43	12 48	
15	43 26.3	52.3	347 34.9	10.8	1	16.6	16.0	60.0	20	04 45	09 35	10 35	11 34	12 33	
16	58 26.3	51.6	2 04.7	10.8	1	00.6	15.9	60.0	N 10	05 02	09 38	10 32	11 26	12 21	
17	73 26.4	51.0	16 34.5	10.9	0	44.7	15.9	60.0	0	05 16	09 40	10 29	11 19	12 09	
18	88 26.4	N17 50.4	31 04.4	10.9	N 0	28.8	15.9	60.0	S 10	05 28	09 42	10 26	11 11	11 57	
19	103 26.4	49.7	45 34.3	10.9	N 0	12.9	15.9	59.9	20	05 40	09 44	10 24	11 04	11 45	
20	118 26.5	49.1	60 04.2	10.9	S 0	03.0	15.9	59.9	30	05 51	09 46	10 20	10 55	11 31	
21	133 26.5	48.5	74 34.1	10.9	0	18.9	15.9	59.9	35	05 56	09 47	10 18	10 50	11 23	
22	148 26.6	47.8	89 04.0	11.0	0	34.8	15.8	59.9	40	06 02	09 49	10 16	10 44	11 14	
23	163 26.6	47.2	103 34.0	11.0	0	50.6	15.9	59.9	45	06 09	09 51	10 14	10 37	11 03	
2 00	178 26.7	N17 46.5	118 04.0	11.0	S 1	06.5	15.8	59.8	S 50	06 16	09 53	10 11	10 30	10 50	
01	193 26.7	45.9	132 34.0	11.0	1	22.3	15.8	59.8	52	06 19	09 54	10 10	10 26	10 44	
02	208 26.7	45.3	147 04.0	11.0	1	38.1	15.8	59.8	54	06 22	09 55	10 08	10 22	10 38	
03	223 26.8	44.6	161 34.0	11.1	1	53.9	15.8	59.8	56	06 25	09 56	10 07	10 18	10 31	
04	238 26.8	44.0	176 04.1	11.0	2	09.7	15.7	59.8	58	06 29	09 57	10 05	10 13	10 23	
05	253 26.9	43.3	190 34.1	11.1	2	25.4	15.7	59.7	S 60	06 33	09 59	10 03	10 08	10 13	
06	268 26.9	N17 42.7	205 04.2	11.1	S 2	41.1	15.7	59.7							
07	283 27.0	42.0	219 34.3	11.1	2	56.8	15.7	59.7							
08	298 27.0	41.4	234 04.4	11.1	3	12.5	15.6	59.7							
09	313 27.1	40.7	248 34.5	11.1	3	28.1	15.6	59.7							
10	328 27.1	40.1	263 04.6	11.1	3	43.7	15.6	59.6							
11	343 27.2	39.5	277 34.7	11.1	3	59.3	15.6	59.6	N 72	21 55	21 24	20 46	19 33		
12	358 27.2	N17 38.8	292 04.8	11.2	S 4	14.9	15.5	59.6	N 70	22 30	21 56	21 34	21 08	20 28	
13	13 27.2	38.2	306 35.0	11.1	4	30.4	15.4	59.6	68	21 20	21 56	21 41	21 24	21 01	
14	28 27.3	37.5	321 05.1	11.1	4	45.8	15.5	59.5	66	21 20	21 57	21 48	21 38	21 26	
15	43 27.3	36.9	335 35.2	11.2	5	01.3	15.4	59.5	64	20 59	22 22	21 58	21 54	21 49	
16	58 27.4	36.2	350 05.4	11.1	5	16.7	15.3	59.5	62	20 42	21 50	21 58	21 59	22 05	
17	73 27.4	35.6	4 35.5	11.1	5	32.0	15.3	59.5	60	20 28	21 26	21 58	22 03	22 14	
18	88 27.5	N17 34.9	19 05.6	11.2	S 5	47.3	15.3	59.4	N 58	20 16	21 08	22 32	22 15	22 26	
19	103 27.5	34.3	33 35.8	11.1	6	02.6	15.2	59.4	56	20 05	20 53	22 03	22 10	22 36	
20	118 27.6	33.6	48 05.9	11.1	6	17.8	15.2	59.4	54	19 56	20 40	21 41	22 13	22 45	
21	133 27.6	33.0	62 36.0	11.1	6	33.0	15.1	59.4	52	19 48	20 29	21 24	22 00	22 53	
22	148 27.7	32.3	77 06.1	11.2	6	48.1	15.1	59.3	50	19 41	20 19	21 09	22 00	23 00	
23	163 27.7	31.7	91 36.3	11.1	7	03.2	15.0	59.3	45	19 25	19 59	20 41	22 01	23 16	
3 00	178 27.8	N17 31.0	106 06.4	11.1	S 7	18.2	15.0	59.3	N 40	19 13	19 43	20 20	22 01	23 28	
01	193 27.8	30.4	120 36.5	11.1	7	33.2	14.9	59.3	35	19 02	19 29	20 03	22 01	23 39	
02	208 27.9	29.7	135 06.6	11.0	7	48.1	14.9	59.3	30	18 52	19 18	19 49	22 02	23 11	
03	223 27.9	29.1	149 36.6	11.1	8	03.0	14.8	59.2	20	18 36	19 00	19 27	22 02	23 23	
04	238 28.0	28.4	164 06.7	11.1	8	17.8	14.8	59.2	N 10	18 23	18 45	19 11	22 03	23 33	
05	253 28.0	27.7	178 36.8	11.0	8	32.6	14.7	59.2	0	18 10	18 31	18 57	22 03	23 43	
06	268 28.1	N17 27.1	193 06.8	11.0	S 8	47.3	14.6	59.2	S 10	17 57	18 19	18 44	22 04	24 37	
07	283 28.1	26.4	207 36.8	11.0	9	01.9	14.6	59.1	20	17 43	18 06	18 33	22 04	23 02	
08	298 28.2	25.8	222 06.8	11.0	9	16.5	14.5	59.1	30	17 28	17 53	18 22	22 05	24 14	
09	313 28.2	25.1	236 36.8	11.0	9	31.0	14.5	59.1	35	17 19	17 46	18 16	22 05	23 13	
10	328 28.3	24.5	251 06.8	11.0	9	45.5	14.4	59.0	40	17 09	17 38	18 10	22 05	23 29	
11	343 28.3	23.8	265 36.8	10.9	9	59.9	14.3	59.0	45	16 57	17 29	18 04	22 05	24 38	
12	358 28.4	N17 23.1	280 06.7	10.9	S 10	14.2	14.3	59.0	S 50	16 43	17 18	17 57	22 06	24 49	
13	13 28.5	22.5	294 36.6	10.9	10	28.5	14.2	59.0	52	16 37	17 14	17 54	22 06	23 55	
14	28 28.5	21.8	309 06.5	10.9	10	42.7	14.1	58.9	54	16 29	17 08	17 51	22 06	23 00	
15	43 28.6	21.2	323 36.4	10.9	10	56.8	14.1	58.9	56	16 21	17 03	17 48	22 06	23 07	
16	58 28.6	20.5	338 06.3	10.8	11	10.9	14.0	58.9	58	16 12	16 56	17 44	22 07	23 14	
17	73 28.7	19.8	352 36.1	10.8	11	24.9	13.9	58.9	S 60	16 01	16 49	17 40	22 07	23 22	
18	88 28.7	N17 19.2	7 05.9	10.8	S 11	38.8	13.8	58.8							
19	103 28.8	18.5	21 35.7	10.7	11	52.6	13.8	58.8							
20	118 28.8	17.9	36 05.4	10.8	12	06.4	13.7	58.8							
21	133 28.9	17.2	50 35.2	10.7	12	20.1	13.6	58.8							
22	148 28.9	16.5	65 04.9	10.7	12	33.7	13.5	58.7							
23	163 29.0	15.9	79 34.6	10.6	12	47.2	13.5	58.7							
	S.D.	15.8	d	0.6	S.D.	16.4	16.2	16.1							
Day									SUN				MOON		
									Eqn. of Time	Mer. Pass.	Mer. Pass.	Upper	Lower	Age	Phase
									00 <sup>a</sup>	12 <sup>a</sup>					
1									m s	m s	h m	h m	h m	d	</

UT (GMT)	ARIES	VENUS -4.2		MARS +1.5		JUPITER -2.7		SATURN +0.5		STARS		
d h	G.H.A.	G.H.A.	Dec.	G.H.A.	Dec.	G.H.A.	Dec.	G.H.A.	Dec.	Name	S.H.A.	Dec.
13 00	112 12.9	168 57.6	S14 59.5	215 07.9	S23 04.5	18 13.4	N23 18.2	183 48.1	S22 04.9	Acamar	315 31.4	S40 20.8
01	127 15.3	184 01.6	59.2	230 08.5	04.7	33 16.2	18.2	198 50.2	04.8	Achernar	335 39.5	S57 17.4
02	142 17.8	199 05.6	58.9	245 09.0	04.9	48 19.0	18.2	213 52.4	04.8	Acrux	173 29.1	S63 02.5
03	157 20.3	214 09.6	58.7	260 09.6	05.0	63 21.8	18.2	228 54.5	04.8	Adhara	255 26.0	S28 57.5
04	172 22.7	229 13.5	58.4	275 10.1	05.2	78 24.6	18.2	243 56.7	04.7	Aldebaran	291 09.3	N16 29.5
05	187 25.2	244 17.5	58.1	290 10.7	05.4	93 27.4	18.2	258 58.8	04.7			
06	202 27.6	259 21.5	S14 57.8	305 11.2	S23 05.6	108 30.2	N23 18.2	274 01.0	S22 04.7	Alioth	166 35.7	N56 00.4
07	217 30.1	274 25.5	57.5	320 11.7	05.8	123 33.0	18.3	289 03.1	04.6	Alkaid	153 12.6	N49 21.4
08	232 32.6	289 29.5	57.2	335 12.3	06.0	138 35.8	18.3	304 05.3	04.6	Al Na'ir	28 05.9	S47 00.8
09	247 35.0	304 33.5	56.9	350 12.8	06.1	153 38.6	18.3	319 07.4	04.6	Alnilam	276 03.9	S 1 12.4
10	262 37.5	319 37.5	56.7	5 13.4	06.3	168 41.4	18.3	334 09.6	04.5	Alphard	218 13.1	S 8 36.9
11	277 40.0	334 41.5	56.4	20 13.9	06.5	183 44.2	18.3	349 11.7	04.5			
12	292 42.4	349 45.5	S14 56.1	35 14.5	S23 06.7	198 46.9	N23 18.3	4 13.9	S22 04.4	Alphecca	126 26.0	N26 44.6
13	307 44.9	4 49.5	55.8	50 15.0	06.9	213 49.7	18.3	19 16.0	04.4	Alpheratz	358 01.9	N29 02.3
14	322 47.4	19 53.5	55.5	65 15.5	07.1	228 52.5	18.4	34 18.2	04.4	Altair	62 25.7	N 8 50.4
15	337 49.8	34 57.5	55.3	80 16.1	07.2	243 55.3	18.4	49 20.3	04.3	Ankaa	353 32.9	S42 21.8
16	352 52.3	50 01.5	55.0	95 16.6	07.4	258 58.1	18.4	64 22.5	04.3	Antares	112 48.1	S26 24.7
17	7 54.8	65 05.6	54.7	110 17.2	07.6	274 00.9	18.4	79 24.6	04.3			
18	22 57.2	80 09.6	S14 54.4	125 17.7	S23 07.8	289 03.7	N23 18.4	94 26.7	S22 04.2	Arcturus	146 11.8	N19 13.7
19	37 59.7	95 13.6	54.2	140 18.3	08.0	304 06.5	18.4	109 28.9	04.2	Atria	108 06.3	S69 00.6
20	53 02.1	110 17.6	53.9	155 18.8	08.1	319 09.3	18.4	124 31.0	04.2	Avior	234 24.7	S59 28.6
21	68 04.6	125 21.6	53.6	170 19.3	08.3	334 12.1	18.5	139 33.2	04.1	Bellatrix	278 50.6	N 6 20.6
22	83 07.1	140 25.6	53.4	185 19.9	08.5	349 14.9	18.5	154 35.3	04.1	Betelgeuse	271 20.0	N 7 24.4
23	98 09.5	155 29.7	53.1	200 20.4	08.7	4 17.7	18.5	169 37.5	04.1			
14 00	113 12.0	170 33.7	S14 52.8	215 21.0	S23 08.9	19 20.4	N23 18.5	184 39.6	S22 04.0	Canopus	264 03.4	S52 41.4
01	128 14.5	185 37.7	52.6	230 21.5	09.0	34 23.2	18.5	199 41.8	04.0	Copella	281 00.1	N45 59.5
02	143 16.9	200 41.7	52.3	245 22.0	09.2	49 26.0	18.5	214 43.9	04.0	Deneb	49 44.0	N45 14.7
03	158 19.4	215 45.8	52.0	260 22.6	09.4	64 28.8	18.5	229 46.1	03.9	Denebola	182 51.3	N14 37.5
04	173 21.9	230 49.8	51.8	275 23.1	09.6	79 31.6	18.6	244 48.2	03.9	Diphda	349 13.5	S18 02.5
05	188 24.3	245 53.8	51.5	290 23.7	09.7	94 34.4	18.6	259 50.4	03.9			
06	203 26.8	260 57.9	S14 51.2	305 24.2	S23 09.9	109 37.2	N23 18.6	274 52.5	S22 03.8	Dubhe	194 12.4	N61 48.0
07	218 29.2	276 01.9	51.0	320 24.7	10.1	124 40.0	18.6	289 54.7	03.8	Elnath	278 34.5	N28 36.1
08	233 31.7	291 06.0	50.7	335 25.3	10.3	139 42.8	18.6	304 56.8	03.8	Eltanin	90 54.8	N51 29.1
09	248 34.2	306 10.0	50.5	350 25.8	10.4	154 45.6	18.6	319 59.0	03.7	Enif	34 04.7	N 9 49.7
10	263 36.6	321 14.0	50.2	5 26.3	10.6	169 48.3	18.6	335 01.1	03.7	Fomahout	15 43.4	S29 40.6
11	278 39.1	336 18.1	49.9	20 26.9	10.8	184 51.1	18.7	350 03.3	03.7			
12	293 41.6	351 22.1	S14 49.7	35 27.4	S23 11.0	199 53.9	N23 18.7	5 05.4	S22 03.6	Gacrux	172 20.7	S57 03.3
13	308 44.0	6 26.2	49.4	50 28.0	11.1	214 56.7	18.7	20 07.6	03.6	Gienah	176 10.3	S17 29.2
14	323 46.5	21 30.2	49.2	65 28.5	11.3	229 59.5	18.7	35 09.7	03.6	Hadar	149 13.3	S60 19.4
15	338 49.0	36 34.3	48.9	80 29.0	11.5	245 02.3	18.7	50 11.9	03.5	Hamal	328 20.6	N23 25.1
16	353 51.4	51 38.3	48.7	95 29.6	11.7	260 05.1	18.7	65 14.0	03.5	Kaus Aust.	84 07.5	S34 23.5
17	8 53.9	66 42.4	48.4	110 30.1	11.8	275 07.9	18.7	80 16.1	03.4			
18	23 56.4	81 46.4	S14 48.2	125 30.7	S23 12.0	290 10.6	N23 18.8	95 18.3	S22 03.4	Kochab	137 19.3	N74 11.3
19	38 58.8	96 50.5	47.9	140 31.2	12.2	305 13.4	18.8	110 20.4	03.4	Markab	13 56.1	N15 09.2
20	54 01.3	111 54.5	47.7	155 31.7	12.3	320 16.2	18.8	125 22.6	03.3	Menkar	314 33.3	N 4 03.2
21	69 03.7	126 58.6	47.4	170 32.3	12.5	335 19.0	18.8	140 24.7	03.3	Menkent	148 28.5	S36 19.3
22	84 06.2	142 02.7	47.2	185 32.8	12.7	350 21.8	18.8	155 26.9	03.3	Miaplacidus	221 42.8	S69 40.4
23	99 08.7	157 06.7	46.9	200 33.3	12.8	5 24.6	18.8	170 29.0	03.2			
15 00	114 11.1	172 10.8	S14 46.7	215 33.9	S23 13.0	20 27.4	N23 18.8	185 31.2	S22 03.2	Mirfak	309 05.4	N49 49.9
01	129 13.6	187 14.8	46.4	230 34.4	13.2	35 30.1	18.9	200 33.3	03.2	Nunki	76 20.4	S26 18.7
02	144 16.1	202 18.9	46.2	245 34.9	13.4	50 32.9	18.9	215 35.5	03.1	Peacock	53 47.2	S56 46.2
03	159 18.5	217 23.0	45.9	260 35.5	13.5	65 35.7	18.9	230 37.6	03.1	Pollux	243 48.7	N28 03.1
04	174 21.0	232 27.0	45.7	275 36.0	13.7	80 38.5	18.9	245 39.8	03.1	Procyon	245 17.7	N 5 15.1
05	189 23.5	247 31.1	45.5	290 36.6	13.9	95 41.3	18.9	260 41.9	03.0			
06	204 25.9	262 35.2	S14 45.2	305 37.1	S23 14.0	110 44.1	N23 18.9	275 44.1	S22 03.0	Rasalhague	96 23.1	N12 33.8
07	219 28.4	277 39.3	45.0	320 37.6	14.2	125 46.9	18.9	290 46.2	03.0	Regulus	208 01.9	N12 00.8
08	234 30.9	292 43.3	44.7	335 38.2	14.4	140 49.6	18.9	305 48.4	02.9	Rigel	281 28.6	S 8 12.7
09	249 33.3	307 47.4	44.5	350 38.7	14.5	155 52.4	19.0	320 50.5	02.9	Rigel Kent.	140 16.2	S60 47.5
10	264 35.8	322 51.5	44.3	5 39.2	14.7	170 55.2	19.0	335 52.7	02.9	Sabik	102 33.0	S15 42.9
11	279 38.2	337 55.6	44.0	20 39.8	14.8	185 58.0	19.0	350 54.8	02.8			
12	294 40.7	352 59.6	S14 43.8	35 40.3	S23 15.0	201 00.8	N23 19.0	5 57.0	S22 02.8	Schedar	350 01.0	N56 29.3
13	309 43.2	8 03.7	43.6	50 40.8	15.2	216 03.6	19.0	20 59.1	02.8	Shaula	96 46.2	S37 05.9
14	324 45.6	23 07.8	43.3	65 41.4	15.3	231 06.3	19.0	36 01.3	02.7	Sirius	258 48.8	S16 42.1
15	339 48.1	38 11.9	43.1	80 41.9	15.5	246 09.1	19.0	51 03.4	02.7	Spica	158 49.8	S11 06.7
16	354 50.6	53 16.0	42.9	95 42.4	15.7	261 11.9	19.1	66 05.6	02.6	Suhail	223 05.1	S43 23.5
17	9 53.0	68 20.0	42.6	110 43.0	15.8	276 14.7	19.1	81 07.7	02.6			
18	24 55.5	83 24.1	S14 42.4	125 43.5	S23 16.0	291 17.5	N23 19.1	96 09.9	S22 02.6	Vega	80 51.3	N38 46.3
19	39 58.0	98 28.2	42.2	140 44.0	16.2	306 20.2	19.1	111 12.0	02.5	Zuben'ubi	137 25.0	S16 00.1
20	55 00.4	113 32.3	42.0	155 44.6	16.3	321 23.0	19.1	126 14.2	02.5			
21	70 02.9	128 36.4	41.7	170 45.1	16.5	336 25.8	19.1	141 16.3	02.5			
22	85 05.3	143 40.5	41.5	185 45.6	16.6	351 28.6	19.1	156 18.4	02.4	Venus	57 21.7	12 34
23	100 07.8	158 44.5	41.3	200 46.2	16.8	6 31.4	19.2	171 20.6	02.4	Mars	102 09.0	9 38
										Jupiter	266 08.4	22 38
										Saturn	71 27.6	11 40

26NVJ096

Figure 4H.—Nautical Almanac right-hand daily page.

18	SUN PLANETS	ARIES	MOON	$\frac{v}{d}$ or Corr <sup>n</sup>	$\frac{v}{d}$ or Corr <sup>n</sup>	$\frac{v}{d}$ or Corr <sup>n</sup>	19	SUN PLANETS	ARIES	MOON	$\frac{v}{d}$ or Corr <sup>n</sup>	$\frac{v}{d}$ or Corr <sup>n</sup>	$\frac{v}{d}$ or Corr <sup>n</sup>
00	4 30.0	4 30.7	4 17.7	0.0 0.0	6.0 1.9	12.0 3.7	00	4 45.0	4 45.8	4 32.0	0.0 0.0	6.0 2.0	12.0 3.9
01	4 30.3	4 31.0	4 17.9	0.1 0.0	6.1 1.9	12.1 3.7	01	4 45.3	4 46.0	4 32.3	0.1 0.0	6.1 2.0	12.1 3.9
02	4 30.5	4 31.2	4 18.2	0.2 0.1	6.2 1.9	12.2 3.8	02	4 45.5	4 46.3	4 32.5	0.2 0.1	6.2 2.0	12.2 4.0
03	4 30.8	4 31.5	4 18.4	0.3 0.1	6.3 1.9	12.3 3.8	03	4 45.8	4 46.5	4 32.7	0.3 0.1	6.3 2.0	12.3 4.0
04	4 31.0	4 31.7	4 18.7	0.4 0.1	6.4 2.0	12.4 3.8	04	4 46.0	4 46.8	4 33.0	0.4 0.1	6.4 2.1	12.4 4.0
05	4 31.3	4 32.0	4 18.9	0.5 0.2	6.5 2.0	12.5 3.9	05	4 46.3	4 47.0	4 33.2	0.5 0.2	6.5 2.1	12.5 4.1
06	4 31.5	4 32.2	4 19.1	0.6 0.2	6.6 2.0	12.6 3.9	06	4 46.5	4 47.3	4 33.4	0.6 0.2	6.6 2.1	12.6 4.1
07	4 31.8	4 32.5	4 19.4	0.7 0.2	6.7 2.1	12.7 3.9	07	4 46.8	4 47.5	4 33.7	0.7 0.2	6.7 2.2	12.7 4.1
08	4 32.0	4 32.7	4 19.6	0.8 0.2	6.8 2.1	12.8 3.9	08	4 47.0	4 47.8	4 33.9	0.8 0.3	6.8 2.2	12.8 4.2
09	4 32.3	4 33.0	4 19.8	0.9 0.3	6.9 2.1	12.9 4.0	09	4 47.3	4 48.0	4 34.2	0.9 0.3	6.9 2.2	12.9 4.2
10	4 32.5	4 33.2	4 20.1	1.0 0.3	7.0 2.2	13.0 4.0	10	4 47.5	4 48.3	4 34.4	1.0 0.3	7.0 2.3	13.0 4.2
11	4 32.8	4 33.5	4 20.3	1.1 0.3	7.1 2.2	13.1 4.0	11	4 47.8	4 48.5	4 34.6	1.1 0.4	7.1 2.3	13.1 4.3
12	4 33.0	4 33.7	4 20.6	1.2 0.4	7.2 2.2	13.2 4.1	12	4 48.0	4 48.8	4 34.9	1.2 0.4	7.2 2.3	13.2 4.3
13	4 33.3	4 34.0	4 20.8	1.3 0.4	7.3 2.3	13.3 4.1	13	4 48.3	4 49.0	4 35.1	1.3 0.4	7.3 2.4	13.3 4.3
14	4 33.5	4 34.2	4 21.0	1.4 0.4	7.4 2.3	13.4 4.1	14	4 48.5	4 49.3	4 35.4	1.4 0.5	7.4 2.4	13.4 4.4
15	4 33.8	4 34.5	4 21.3	1.5 0.5	7.5 2.3	13.5 4.2	15	4 48.8	4 49.5	4 35.6	1.5 0.5	7.5 2.4	13.5 4.4
16	4 34.0	4 34.8	4 21.5	1.6 0.5	7.6 2.3	13.6 4.2	16	4 49.0	4 49.8	4 35.8	1.6 0.5	7.6 2.5	13.6 4.4
17	4 34.3	4 35.0	4 21.8	1.7 0.5	7.7 2.4	13.7 4.2	17	4 49.3	4 50.0	4 36.1	1.7 0.6	7.7 2.5	13.7 4.5
18	4 34.5	4 35.3	4 22.0	1.8 0.6	7.8 2.4	13.8 4.3	18	4 49.5	4 50.3	4 36.3	1.8 0.6	7.8 2.5	13.8 4.5
19	4 34.8	4 35.5	4 22.2	1.9 0.6	7.9 2.4	13.9 4.3	19	4 49.8	4 50.5	4 36.6	1.9 0.6	7.9 2.6	13.9 4.5
20	4 35.0	4 35.8	4 22.5	2.0 0.6	8.0 2.5	14.0 4.3	20	4 50.0	4 50.8	4 36.8	2.0 0.7	8.0 2.6	14.0 4.6
21	4 35.3	4 36.0	4 22.7	2.1 0.6	8.1 2.5	14.1 4.3	21	4 50.3	4 51.0	4 37.0	2.1 0.7	8.1 2.6	14.1 4.6
22	4 35.5	4 36.3	4 22.9	2.2 0.7	8.2 2.5	14.2 4.4	22	4 50.5	4 51.3	4 37.3	2.2 0.7	8.2 2.7	14.2 4.6
23	4 35.8	4 36.5	4 23.2	2.3 0.7	8.3 2.6	14.3 4.4	23	4 50.8	4 51.5	4 37.5	2.3 0.7	8.3 2.7	14.3 4.6
24	4 36.0	4 36.8	4 23.4	2.4 0.7	8.4 2.6	14.4 4.4	24	4 51.0	4 51.8	4 37.7	2.4 0.8	8.4 2.7	14.4 4.7
25	4 36.3	4 37.0	4 23.7	2.5 0.8	8.5 2.6	14.5 4.5	25	4 51.3	4 52.0	4 38.0	2.5 0.8	8.5 2.8	14.5 4.7
26	4 36.5	4 37.3	4 23.9	2.6 0.8	8.6 2.7	14.6 4.5	26	4 51.5	4 52.3	4 38.2	2.6 0.8	8.6 2.8	14.6 4.7
27	4 36.8	4 37.5	4 24.1	2.7 0.8	8.7 2.7	14.7 4.5	27	4 51.8	4 52.5	4 38.5	2.7 0.9	8.7 2.8	14.7 4.8
28	4 37.0	4 37.8	4 24.4	2.8 0.9	8.8 2.7	14.8 4.6	28	4 52.0	4 52.8	4 38.7	2.8 0.9	8.8 2.9	14.8 4.8
29	4 37.3	4 38.0	4 24.6	2.9 0.9	8.9 2.7	14.9 4.6	29	4 52.3	4 53.1	4 38.9	2.9 0.9	8.9 2.9	14.9 4.8
30	4 37.5	4 38.3	4 24.9	3.0 0.9	9.0 2.8	15.0 4.6	30	4 52.5	4 53.3	4 39.2	3.0 1.0	9.0 2.9	15.0 4.9
31	4 37.8	4 38.5	4 25.1	3.1 1.0	9.1 2.8	15.1 4.7	31	4 52.8	4 53.6	4 39.4	3.1 1.0	9.1 3.0	15.1 4.9
32	4 38.0	4 38.8	4 25.3	3.2 1.0	9.2 2.8	15.2 4.7	32	4 53.0	4 53.8	4 39.7	3.2 1.0	9.2 3.0	15.2 4.9
33	4 38.3	4 39.0	4 25.6	3.3 1.0	9.3 2.9	15.3 4.7	33	4 53.3	4 54.1	4 39.9	3.3 1.1	9.3 3.0	15.3 5.0
34	4 38.5	4 39.3	4 25.8	3.4 1.0	9.4 2.9	15.4 4.7	34	4 53.5	4 54.3	4 40.1	3.4 1.1	9.4 3.1	15.4 5.0
35	4 38.8	4 39.5	4 26.1	3.5 1.1	9.5 2.9	15.5 4.8	35	4 53.8	4 54.6	4 40.4	3.5 1.1	9.5 3.1	15.5 5.0
36	4 39.0	4 39.8	4 26.3	3.6 1.1	9.6 3.0	15.6 4.8	36	4 54.0	4 54.8	4 40.6	3.6 1.2	9.6 3.1	15.6 5.1
37	4 39.3	4 40.0	4 26.5	3.7 1.1	9.7 3.0	15.7 4.8	37	4 54.3	4 55.1	4 40.8	3.7 1.2	9.7 3.2	15.7 5.1
38	4 39.5	4 40.3	4 26.8	3.8 1.2	9.8 3.0	15.8 4.9	38	4 54.5	4 55.3	4 41.1	3.8 1.2	9.8 3.2	15.8 5.1
39	4 39.8	4 40.5	4 27.0	3.9 1.2	9.9 3.1	15.9 4.9	39	4 54.8	4 55.6	4 41.3	3.9 1.3	9.9 3.2	15.9 5.2
40	4 40.0	4 40.8	4 27.2	4.0 1.2	10.0 3.1	16.0 4.9	40	4 55.0	4 55.8	4 41.6	4.0 1.3	10.0 3.3	16.0 5.2
41	4 40.3	4 41.0	4 27.5	4.1 1.3	10.1 3.1	16.1 5.0	41	4 55.3	4 56.1	4 41.8	4.1 1.3	10.1 3.3	16.1 5.2
42	4 40.5	4 41.3	4 27.7	4.2 1.3	10.2 3.1	16.2 5.0	42	4 55.5	4 56.3	4 42.0	4.2 1.4	10.2 3.3	16.2 5.3
43	4 40.8	4 41.5	4 28.0	4.3 1.3	10.3 3.2	16.3 5.0	43	4 55.8	4 56.6	4 42.3	4.3 1.4	10.3 3.3	16.3 5.3
44	4 41.0	4 41.8	4 28.2	4.4 1.4	10.4 3.2	16.4 5.1	44	4 56.0	4 56.8	4 42.5	4.4 1.4	10.4 3.4	16.4 5.3
45	4 41.3	4 42.0	4 28.4	4.5 1.4	10.5 3.2	16.5 5.1	45	4 56.3	4 57.1	4 42.8	4.5 1.5	10.5 3.4	16.5 5.4
46	4 41.5	4 42.3	4 28.7	4.6 1.4	10.6 3.3	16.6 5.1	46	4 56.5	4 57.3	4 43.0	4.6 1.5	10.6 3.4	16.6 5.4
47	4 41.8	4 42.5	4 28.9	4.7 1.4	10.7 3.3	16.7 5.1	47	4 56.8	4 57.6	4 43.2	4.7 1.5	10.7 3.5	16.7 5.4
48	4 42.0	4 42.8	4 29.2	4.8 1.5	10.8 3.3	16.8 5.2	48	4 57.0	4 57.8	4 43.5	4.8 1.6	10.8 3.5	16.8 5.5
49	4 42.3	4 43.0	4 29.4	4.9 1.5	10.9 3.4	16.9 5.2	49	4 57.3	4 58.1	4 43.7	4.9 1.6	10.9 3.5	16.9 5.5
50	4 42.5	4 43.3	4 29.6	5.0 1.5	11.0 3.4	17.0 5.2	50	4 57.5	4 58.3	4 43.9	5.0 1.6	11.0 3.6	17.0 5.5
51	4 42.8	4 43.5	4 29.9	5.1 1.6	11.1 3.4	17.1 5.3	51	4 57.8	4 58.6	4 44.2	5.1 1.7	11.1 3.6	17.1 5.6
52	4 43.0	4 43.8	4 30.1	5.2 1.6	11.2 3.5	17.2 5.3	52	4 58.0	4 58.8	4 44.4	5.2 1.7	11.2 3.6	17.2 5.6
53	4 43.3	4 44.0	4 30.3	5.3 1.6	11.3 3.5	17.3 5.3	53	4 58.3	4 59.1	4 44.7	5.3 1.7	11.3 3.7	17.3 5.6
54	4 43.5	4 44.3	4 30.6	5.4 1.7	11.4 3.5	17.4 5.4	54	4 58.5	4 59.3	4 44.9	5.4 1.8	11.4 3.7	17.4 5.7
55	4 43.8	4 44.5	4 30.8	5.5 1.7	11.5 3.5	17.5 5.4	55	4 58.8	4 59.6	4 45.1	5.5 1.8	11.5 3.7	17.5 5.7
56	4 44.0	4 44.8	4 31.1	5.6 1.7	11.6 3.6	17.6 5.4	56	4 59.0	4 59.8	4 45.4	5.6 1.8	11.6 3.8	17.6 5.7
57	4 44.3	4 45.0	4 31.3	5.7 1.8	11.7 3.6	17.7 5.5	57	4 59.3	5 00.1	4 45.6	5.7 1.9	11.7 3.8	17.7 5.8
58	4 44.5	4 45.3	4 31.5	5.8 1.8	11.8 3.6	17.8 5.5	58	4 59.5	5 00.3	4 45.9	5.8 1.9	11.8 3.8	17.8 5.8
59	4 44.8	4 45.5	4 31.8	5.9 1.8	11.9 3.7	17.9 5.5	59	4 59.8	5 00.6	4 46.1	5.9 1.9	11.9 3.9	17.9 5.8
60	4 45.0	4 45.8	4 32.0	6.0 1.9	12.0 3.7	18.0 5.6	60	5 00.0	5 00.8	4 46.3	6.0 2.0	12.0 3.9	18.0 5.9

26NVJ095

Figure 4I.—Nautical Almanac Increments and Corrections page.

ASSIGNMENT 5

Textbook Assignment: "Weather Observation," chapter 10, pages 10-1 through 10-27.

- 5-1. What agency is responsible for U.S. Navy meteorological and oceanographic supports and services?
1. NAVOCEANCEN
  2. Weather Bureau
  3. NOAA
  4. National Weather Service
- 5-2. Which of the following activities are primary contributors to NAVOCEANCEN?
1. Navy units at sea
  2. Marine Corps units only
  3. Navy and Marine Corps units
  4. National Weather Services
- 5-3. What are the percentages of (a) nitrogen and (b) oxygen in Earth's atmosphere?
1. (a) 57 (b) 21
  2. (a) 21 (b) 75
  3. (a) 78 (b) 21
  4. (a) 78 (b) 25
- 5-4. In which region is the quantity of water vapor much greater?
1. Poles
  2. Oceans
  3. Land
  4. Equator
- 5-5. Moist air with a temperature of 50° is heavier than drier air of the same temperature.
1. True
  2. False
- 5-6. In the Northern Hemisphere, we refer to winds of high pressure by which of the following terms?
1. Hurricane
  2. Cyclone
  3. Anti-cyclone
  4. Typhoon
- 5-7. Which of the following types of winds are associated with doldrums?
1. Tropical breezes only
  2. Trade winds
  3. Prevailing winds only
  4. Tropical breezes and prevailing winds

- 5-8. Between the prevailing westerly and the trade wind zones lies a subtropical high referred to as the
1. horse latitudes
  2. doldrums
  3. polar front zones
  4. polar easterlies

IN ANSWERING QUESTIONS 5-9 THROUGH 5-12, SELECT FROM COLUMN B THE DESCRIPTION THAT MATCHES THE WINDS IN COLUMN A. RESPONSES WILL ONLY BE USED ONCE.

<u>A. WINDS</u>	<u>B. DESCRIPTION</u>
5-9. Doldrums	1. Results from the deflection caused by the coriolis force as air moves polewards
5-10. Tradewinds	2. Areas of subtropical high-pressure
5-11. Horse latitudes	3. Move north and south of the equator with the Sun
5-12. Prevailing westerlies	4. Found north and south of the doldrums
<hr/>	
5-13. What type of weather occurs when doldrums are absent in the equatorial region?	1. Rain squalls 2. Thunder storms 3. Fog 4. Haze
5-14. Where are horse latitudes located?	1. 0° to 15° 2. 20° to 35° 3. 30° to 40° 4. 30° to 50°
5-15. Which of the following cloud types is NOT a low etage cloud?	1. Conolonimbus 2. Stratocumulus 3. Nimbostratus 4. Straus



- 5-16. Which of the following cloud types is thin, wispy, or hairlike?
1. Cirrus
  2. Cirrocumulus
  3. Cirrostratus
  4. Stratocumulus

---

IN ANSWERING QUESTIONS 5-17 THROUGH 5-20, SELECT FROM COLUMN B THE DESCRIPTION THAT MATCHES THE CLOUD LISTED IN COLUMN A. RESPONSES WILL ONLY BE USED ONCE.

	<u>A. CLOUD</u>	<u>B. DESCRIPTION</u>
5-17.	Cirrocumulus	1. Fattened globular masses
5-18.	Alto cumulus	2. Dense vertical development
5-19.	Stratocumulus	3. Mackerel sky
5-20.	Cumulus	4. Soft and gray with dark spots

- 
- 5-21. What is the average atmospheric pressure at Earth's surface?
1. 1010.4 MB
  2. 1013.2 MB
  3. 1015.7 MB
  4. 1017.8 MB
- 5-22. What is the approximate average atmospheric pressure per square inch at sea level?
1. 11
  2. 15
  3. 17
  4. 18
- 5-23. How accurately can an aneroid barometer be read?
1. 1.00
  2. 0.50
  3. 0.10
  4. 0.01
- 5-24. What occurs along the boundary when distinctly different air masses touch?
1. Haze
  2. Fog
  3. Cloudiness
  4. Clearing

- 5-25. How is the meeting of distinctly different air masses referred?

1. Low pressure
2. High pressure
3. Trough
4. Front

- 5-26. When you are drawing isobars, what is the value of the base millibar?

1. 900 mb
2. 950 mb
3. 1000 mb
4. 1050 mb

- 5-27. Isobars are lines drawn on a chart that connect areas of equal

1. height
2. depth
3. pressure
4. temperature

- 5-28. What is the millibar separation value between each isobar in the area from 25° to the South Pole?

1. 6 mb
2. 2 mb
3. 10 mb
4. 4 mb

- 5-29. Which of the following rules should you keep in mind when you are drawing isobars?





1. The isobaric pattern is apt to be complicated when the wind circulation is strong
2. The isobaric pattern is apt to be simple with a large scale movement of air
3. Isobars are faired by including minor variations in wind circulation
4. Isobars are not affected by the strength of wind circulation

- 5-30. When you are analyzing isobars and accompanying weather, you should remember that the closer the isobars are together the

1. greater the winds will be in that area
2. greater the amount of precipitation in that area
3. slower the winds will be in that area
4. larger the area of high or low pressure

- 5-31. If when analyzing isobars you determine you have a high-pressure system, the wind will blow in which of the following directions?
1. In toward the center, across the isobars
  2. In toward the center, parallel to the isobars
  3. Out from the center, across the isobars
  4. Out from the center, parallel to the isobars
- 5-32. Which of the following tendencies occurs after a front passes?
1. Pressure usually falls
  2. Pressure usually rises
  3. Pressure stabilizes
  4. Pressure is erratic
- 5-33. Which of the following wind characteristics accompany a warm front in the Northern Hemisphere?
1. The wind speed decreases as the front approaches and shifts abruptly once it reaches your position
  2. The wind speed increases as the front approaches and rarely shifts as abruptly as a cold front
  3. The wind speed decreases as the front approaches and will shift on passage in a clockwise direction
  4. The wind speed increases as the front approaches and will shift on passage in a counterclockwise direction
- 5-34. During a warm front passage, how is temperature affected?
1. Rises slowly
  2. Rises gradually
  3. Rises quickly
  4. Starts slowly and increases with the passage

IN ANSWERING QUESTIONS 5-35 THROUGH 5-41, SELECT THE SYMBOL FROM COLUMN B THAT MATCHES THE DESCRIPTOR IN COLUMN A. RESPONSES MAY BE USED MORE THAN ONCE. REFER TO FIGURE 10-8 IN YOUR TEXT.

A. DESCRIPTOR	B. SYMBOLS
5-35. Warm front	1. 
5-36. Stationary front	2. 
5-37. Cold front	3. 
5-38. Occluded front	4. 
5-39. Blue line	
5-40. Red line	
5-41. Red and blue line	

26NP0001

- 5-42. With the approach of a cold front, the initial wind normally blows from which direction?
1. Southwest
  2. Northwest
  3. Southeast
  4. Northeast
- 5-43. Which of the following characteristics is typical of the passage of a slow-moving cold front?
1. Precipitation is continuous and long lasting
  2. The temperature is cold before the front's passage and increases rapidly after passage
  3. The dew point raises with the passage of a slow-moving cold front
  4. Gusty winds will rarely accompany a cold front's passage
- 5-44. Which of the following characteristics is typical of the temperature after the passage of a cold front?
1. It will increase very slowly
  2. It will increase very rapidly
  3. It will decrease very slowly
  4. It will decrease very rapidly
- 5-45. Dew point temperature generally helps to locate fronts, except in mountainous regions.
1. True
  2. False

5-46. Your ship is heading north at 15 knots and true wind is blowing from the south at 20 knots, what is the relative wind speed?

1. 5 Kn
2. 15 Kn
3. 20 Kn
4. 35 Kn

5-47. Your ship is heading 225° at 5 knots, and the relative wind is blowing on your starboard bow (070°R) at 17 knots. What is the apparent wind speed and direction?

1. 070° at 22 Kn
2. 155° at 12 Kn
3. 225° at 5 Kn
4. 295° at 17 Kn

5-48. Anemometer indicates which type of wind?

1. Actual
2. True
3. Apparent
4. Relative

5-49. What is the maximum wind speed indicated on a handheld anemometer?

1. 60 Kn
2. 70 Kn
3. 80 Kn
4. 100 Kn

5-50. When visual estimation of wind speed is being used, what is meant by fetch area?

1. Area where waves are being generated by current
2. Area where swells are being generated by wind
3. Area where waves are being generated by wind
4. Area where swells are being generated by current

IN ANSWERING QUESTIONS 5-51 THROUGH 5-56, SELECT FROM COLUMN B THE CHARACTERISTIC THAT MATCHES THE SEA CONDITION LISTED IN COLUMN A. RESPONSE WILL BE USED MORE THAN ONCE.

	A. SEA CONDITION	B. CHARACTERISTICS
5-51.	Gentle breeze	1. Moderately high winds
5-52.	Gale	2. Gale
5-53.	48-55 knots	3. Very high waves with long overhanging crests
5-54.	7-10 knots	4. Large wavelets, crests begin to break
5-55.	Storm	
5-56.	34-40-knots	

5-57. Which publication contains information on figuring true wind?

1. H.O. Pub 17
2. Pub 217
3. Pub 1310
4. Pub 151

5-58. What is the Fahrenheit equivalent to 23° Celsius?

1. 71
2. 72.1
3. 73.4
4. 77.5

5-59. What is the Celsius equivalent of 47° Fahrenheit?

1. 5.7°
2. 8.3°
3. 8.7°
4. 9.3°

## ASSIGNMENT 6

Textbook Assignment: "Voyage Planning," chapter 12, pages 12-1 through 12-26.

- 
- |   |   |
|---|---|
| <p>6-1. The collective title given to preplanned evolutions and events is</p> <ol style="list-style-type: none"> <li>1. deployment considerations</li> <li>2. voyage planning</li> <li>3. operational assignments</li> <li>4. geographic reassignments</li> </ol>   | <p>6-6. Planned intended movement (PIM) moves along the ship's intended track at the</p> <ol style="list-style-type: none"> <li>1. ship's present speed</li> <li>2. SOA of each leg</li> <li>3. speed desired by each OOD</li> <li>4. speed determined by the OTSR reply</li> </ol>                       |
| <p>6-2. Completing your ship's intended track on the proper chart format is determined by the</p> <ol style="list-style-type: none"> <li>1. distance to be traveled</li> <li>2. availability of classified charts</li> <li>3. OPORD requirements</li> <li>4. length of cruise</li> </ol>  | <p>6-7. When labeling a PIM, what type of time is used?</p> <ol style="list-style-type: none"> <li>1. LMT</li> <li>2. GMT</li> <li>3. ZT</li> <li>4. UCT</li> </ol>   |
| <p>6-3. Which of the following statements concerning the drawing of great circle tracks is incorrect?</p> <ol style="list-style-type: none"> <li>1. Great circles drawn on a gnomonic chart are straight lines</li> <li>2. Great circle charts compared to small scale Mercator charts have minimal distortion</li> <li>3. Great circle sailing is mandatory in all cases</li> <li>4. Great circle sailings are initially plotted on gnomonic charts and then transferred to Mercator charts</li> </ol> | <p>6-8. How often are DR positions indicated on a PIM?</p> <ol style="list-style-type: none"> <li>1. Every 6 hr</li> <li>2. Every 2 hr</li> <li>3. Every 8 hr</li> <li>4. Every 4 hr</li> </ol>   |
| <p>6-4. Compared to plotting on the great circle chart, plotting around an obstacle on a Mercator chart will impact the most on the</p> <ol style="list-style-type: none"> <li>1. departure</li> <li>2. destination position</li> <li>3. plotting instruments used</li> <li>4. ship's total track distance</li> </ol>   | <p>6-9. There is no difference between planning coastal tracks and great circle tracks.</p> <ol style="list-style-type: none"> <li>1. True</li> <li>2. False</li> </ol>   |
| <p>6-5. Your ship's great circle track across the Atlantic Ocean is divided into chords to enable you to transfer the track to Mercator charts. Each chord normally represents how many nautical miles?</p> <ol style="list-style-type: none"> <li>1. 150</li> <li>2. 200</li> <li>3. 300</li> <li>4. 450</li> </ol>  | <p>6-10. Which of the following distances is the maximum range when planning a coastal navigation track?</p> <ol style="list-style-type: none"> <li>1. 20 nmi</li> <li>2. 25 nmi</li> <li>3. 50 nmi</li> <li>4. 60 nmi</li> </ol>   |
|   | <p>6-11. What is the minimum distance a track may be permitted to pass a shoal?</p> <ol style="list-style-type: none"> <li>1. 3 miles</li> <li>2. 5 miles</li> <li>3. 10 miles</li> <li>4. 20 miles</li> </ol>  |
|   | <p>6-12. When transferring a great circle to a coastal chart, what type of charts must be used?</p> <ol style="list-style-type: none"> <li>1. Charts that show most detail</li> <li>2. Charts that show best scale</li> <li>3. Charts that show the largest scale</li> <li>4. All of the above</li> </ol> |

- 6-13. What is the most critical track a navigator will lay out?
1. Great circle
  2. Precision anchorage
  3. Coastal track
  4. Restricted water
- 6-14. How is a red sounding defined?
1. 10 feet beneath the keel
  2. 15 feet beneath the keel
  3. Any shoal water
  4. Any depth deemed a danger by the CO
- 6-15. How is a yellow sounding defined?
1. Any depth deemed a danger by the CO
  2. Any depth beneath the keel that indicates danger
  3. Any depth beneath the keel that indicates potential danger
  4. Any shoal water
- 6-16. Navigational aids may be marked using any color except red?
1. True
  2. False
- 6-17. When should a slide bar be used?
1. Always
  2. When turning 90°
  3. When transiting a narrow river
  4. Never in coastal waters
- 6-18. Your ship is left of track, when should you start the turn?
1. Early on the turn bearing
  2. Late on the turn bearing
  3. Early on the slide bar
  4. Late on the slide bar
- 6-19. On larger vessels, how many knots of wind can equal 1 knot of current?
1. 1.0
  2. 1.5
  3. 5.0
  4. 10.0
- 6-20. Who is responsible for selecting an anchorage in other than established ports?
1. The leading QM
  2. The navigator
  3. The operations officer
  4. The commanding officer

- 6-21. Which of the following sites is NOT considered to be a good choice for an anchorage?
1. Shallow water
  2. A mud bottom
  3. A sand bottom
  4. An area with no current
- 6-22. What is the major danger when you anchor in water that is too deep?
1. Type of bottom is unknown
  2. The anchor may drag
  3. Time required to anchor
  4. Underwater hazards
- 6-23. What identifies specific anchorages on NOS charts?
1. Letters only
  2. Numbers only
  3. Letters and numbers
  4. Roman numerals

---

IN ANSWERING QUESTIONS 6-24 THROUGH 6-27, SELECT THE ANCHORING TERM LISTED IN COLUMN B THAT MATCHES THE ANCHORING DESCRIPTION IN COLUMN A. NO RESPONSE MAY BE USED MORE THAN ONCE.

	<u>A. ANCHORING DESCRIPTION</u>	<u>B. ANCHORING TERM</u>
6-24.	Length varies according to ship size	1. Letting go circle
6-25.	A line that indicates relation to track	2. Range circle
6-26.	A distance that is equal to the length from the hawsepipe to the pelorus	3. Head bearing
6-27.	Measured from the letting go circle	4. Approach track
6-28.	Which of the following circles is centered at the calculated position of the anchor and whose radius equals the ship's length plus the scope of chain?	
		1. Range circle
		2. Letting go circle
		3. Drag circle
		4. Swing circle

- 6-29. What are two types of bearings associated with approaching an anchorage?
1. Head and letting go
  2. Head and beam
  3. Beam and letting go
  4. Range and head
- 6-30. When laying out a head bearing for an anchorage, which factor(s) must be considered?
1. The lay of the land
  2. Wind
  3. Current
  4. Wind and current
- 6-31. What is the purpose of an anchoring template?
1. To provide the most convenient plotting surface
  2. To enable a ship to quickly shift to an alternate anchorage
  3. To protect the chart from excessive wear
  4. Both 2 and 3 above
- 6-32. When approaching an anchorage, when should the ship slow to 5 to 7 knots?
1. 1,000 yd
  2. 1,250 yd
  3. 1,500 yd
  4. 1,750 yd
- 6-33. What effects the range from the letting go circle that engines should be stopped?
1. Wind only
  2. Current only
  3. Both 1 and 2 above
  4. Engines are always stopped 300 yards from the letting go circle
- 6-34. What should the navigator do when the anchor is let go?
1. Sound the bottom
  2. Record the ship's heading
  3. Mark the head bearing
  4. Check magnetic deviation
- 6-35. What is meant by the term "veering the anchor"?
1. Letting out chain
  2. Swiveling the anchor
  3. Setting the anchor
  4. Taking in chain
- 6-36. What is the normal scope of chain used when anchoring?
1. Two to four times the depth of water
  2. Three to five times the depth of water
  3. Four to six times the depth of water
  4. Five to seven times the depth of water
- 6-37. How is the term "setting the anchor" defined?
1. Anchor secured on deck
  2. Anchor setting on the bottom
  3. Anchor fluke dug into the bottom
  4. Weight of the anchor chain holding the anchor in place
- 6-38. When is the second swing circle drawn?
1. At the same time the initial anchor circle is drawn
  2. After veering the anchor chain
  3. After the anchor chain is set
  4. After the final position has been established
- 6-39. After the drag circle is drawn, all fixes should fall within the drag circle.
1. True
  2. False
- 6-40. Why is it desirable to select lighted aids for fixing the ship's position at anchor?
1. Lighted aids are more prominent
  2. The majority of aids are lighted
  3. Lighted aids will be visible both by day and night
  4. Unlighted aids are normally not properly charted
- 6-41. How often should the anchor bearing watch obtain a fix?
1. Every 15 min
  2. Every 30 min
  3. Every hour
  4. When the ship's heading changes more than 15°
- 6-42. What should immediately be done if a fix falls outside the drag circle?
1. Take another fix
  2. Inform the OOD
  3. Inform the CDO
  4. Watch the fixes more closely

- 6-43. What should you assume if a fix plots outside the drag circle?
1. The anchor was improperly plotted
  2. The drag circle was improperly plotted
  3. The tide has shifted
  4. The anchor is dragging
- 6-44. What may cause a ship to drag anchor without any indication of movement?
1. High winds
  2. High swells
  3. High sea waves
  4. Tidal shift
- 6-45. What action may be taken to prevent the anchor from dragging?
1. Veer the anchor chain
  2. Shorten the chain
  3. Shorten the chain's catenary
  4. Put the main engines on the line
- 6-46. When anchored in high wind, what official is stationed on the bridge?
1. OOD
  2. JOOD
  3. Conning officer
  4. Leading QM
- 6-47. Who is responsible for giving the navigation brief?
1. Leading QM
  2. Navigator
  3. Operations officer
  4. Any of the above
- 6-48. Commander Naval Surface Forces Atlantic and Pacific require navigational briefings to be held prior to getting underway. The format can be found in COMNAVSURFINST 3530.2.
1. True
  2. False
- 6-49. The navigation brief is given how many hours prior to getting under way?
1. 8 hr
  2. 12 hr
  3. 24 hr
  4. 48 hr
- 6-50. Which of the following evolutions should be accomplished 8 hours prior to getting under way?
1. Verify tugs/pilot
  2. Energize radar repeaters
  3. Determine gyro error
  4. Check navigation lights
- 6-51. The navigation brief is given how many hours prior to entering port?
1. 8 hr
  2. 12 hr
  3. 24 hr
  4. No setting time
- 6-52. Prior to entering port, when is the ship's whistle tested?
1. 15 min
  2. 30 min
  3. 45 min
  4. 1 hr
- 6-53. When should a steering test be conducted?
1. 30 minutes prior to sea detail
  2. 30 minutes prior to approaching shoal water
  3. Only if the steering is sluggish
  4. 45 minutes prior to approaching shoal water
- 6-54. When should the OOD request permission to enter port?
1. 30 min
  2. 45 min
  3. 1 hr
  4. Any time prior to arriving at sea buoy

